

# Development of PLC Based Navigation System for Mobile Robot

Seha Saffar<sup>1</sup>, Fairul Azni Jafar<sup>2</sup>, Zamberi Jamaludin<sup>2</sup>

<sup>1</sup>Centre for Graduate Studies, Universiti Teknikal Malaysia Melaka.

<sup>2</sup>Faculty of Manufacturing Engineering, Universiti Teknikal Malaysia Melaka,  
Hang Tuah Jaya, 76100 Durian Tunggal, Melaka, Malaysia.  
sehasaffar@yahoo.com

**Abstract**— A programmed machine called mobile robot has a skilled of movement in any controlled environment. Microcontroller/microprocessor based controllers is known as the best controller for mobile robot. The difficulties of applying the Microcontroller/microprocessor based controllers as well as writing the program in it bring the attention of researches to look for easier controller such as Programmable Logic Controller (PLC). Yet, it is still very few mobile robots which used PLC as the navigation controller. This project is motivated by this situation, with a consideration to develop the type of mobile robot which is controlled by PLC because of the lack of mobile robot developed under control by PLC. Therefore, this project is trying to develop a PLC based navigation system for mobile robot, by developing the algorithm and analyze the performance of the mobile robot able to follow line hypothetically. All related works with comprised information about mobile robot, controller system and application of PLC in mobile robot navigation system are reviewed. The method to complete this project is starting with designing the program using PLC software, apply the commissioning of the PLC into a mobile robot with complete circuit wiring and analyze the project. To analyze the project, a navigation experiment is done under 2 different paths and each path is repeated for 5 times. The experiment was represented using line graph in order to know the effectiveness of the mobile robot movement using PLC system. Both path showed a good result with tolerance about 5-10% of error thus it prove the hypothesis. Lastly, as a conclusion, the significant finding in this project is proved that PLC is able to be applied as line following mobile robot control system.

**Index Terms**— Automated guided vehicle; Controller; Mobile robot; Navigation system; Programmable logic controller.

## I. INTRODUCTION

For centuries, the revolution in technology undoubtedly is the robot. Starting from dream of a man to be free of the drudgery of manual labor using automatic device until currently in 21<sup>st</sup> century where robot has been applied to almost all types of labor industries. Mobile robot is defined as a programmed machine that is skilled of movement in any specified surroundings. They have capabilities to move around in their environments and are not fixed to one physical location as fixed robot. Mobile robot can be classified by a few characteristics which are: the environment; the device or tools they used to move. While most of the fixed robots can be found in manufacturing environment, robot with mobility function gave a lot advantages in helping humans in environment such

as agriculture land, hospital, hazardous field, household as well as manufacturing environment.

Every day a growth of robot can be seen with increasing human like capabilities, such as recognizing objects and moving around independent of human control [1]. Furthermore, there has been much interest on achieving educational and research goals by the use of mobile robots [2]. Thus, a low cost robot platform commonly used and frequently controlled by some kind of microcontrollers PC with interface cards together with the growth of mobile robot. There are less mobile robots with industrial based system being developed. Thus, it motivates our research group to do a project in developing a type of mobile robot with a controller of Programmable Logic Controller (PLC). With embedded system, where engineer can build their own system according to what they want and program it according to their hardware, it make PIC is much favorable among engineers. But, for some people who requires a system that's ready-made and simple, PLC will be the answer.

Nowadays, with the expansion of industrial mobile robot, there are lots of components available in market that can be used to create a complete control and sensor system of a mobile robot. Thus, by using these components, electrical hardware development is not necessary, which will speed up the development time and decrease the cost. Using PLC on board, what left is only constructing the program and researchers can concentrate on the algorithms, rather than developing the hardware. Furthermore, PLC is suitable for manufacturing industries because it is more simple compare to microcontrollers/microprocessor based controllers. (e.g. C Language). But yet, it's still very less mobile robot which used PLC as the navigation controller and it's not impossible to create a simple and flexible mobile robot based on PLC navigation system. Therefore, this project is trying to develop a PLC based navigation system for mobile robot, study the algorithm and analyze the performance of the mobile robot.

The purpose of this project is to develop navigation system for mobile robot. The navigation system covers PLC controller including both software and hardware to navigate the mobile robot. This project concentrate on the application of PLC controller of Keyence PLC KV-16T, which attached to mobile robot. The successfulness in development of PLC based navigation system for mobile robot will be decided based on five good results in the experiment of mobile robot navigation.

Precise control on the navigation and localization of the mobile robot will not be considered in this period of study. The analysis and design process will be focus on the way PLC system is design and how the PLC system can be tested as well as fault identification.

## II. LITERATURE REVIEW

Mobile robots represent an interaction technology, which move the boundaries of what is possible within automation. Thus, mobile robot is a subject of a major focus in development and research environments which is used in many different areas, e.g. home-care, health-care, space exploration, manufacturing industries and even military operations [3]. For example, AGV robots can autonomously deliver parts between various assembly stations by following special electrical guided wires using a custom sensor [4]. Starting in the year 2008 where industries starting to compete each other in using mobile robot as their automation domain. Thereby, starting from that year until currently, there is increasing demand in mobile robot application.

A proposal of a wheelchair which consists of mobile robot system was designed the wheeled mobile robot using a PIC microcontroller embedded on the robot and adept of controlling two drive channels with a few other elements such as H-Bridge control Circuits, LED/phototransistor and range detection sensors, takes an input signals from sensors and control the motion of robot is taken from PIC microcontroller [5]. The authors also mention by using a simple controller of PIC microcontroller, the rotation of motor or motion of the robot can be controlled easier. Same as [11], they design a main circuit of their new low cost remotely operated vehicle (ROV) by using PIC microcontroller. Arduino microcontroller and Raspberry Pi was also used as controller in mobile inspection robot for heating, ventilation and air conditioning (HVAC) ducting system [12]. The authors used the Arduino for brain of the mobile robot and Raspberry Pi as camera or input controller.

Currently, a well-known industrial controller which is frequently used in manufacturing industry for production line called PLC take place as mobile robot controller. PLC is user friendly, micro-controller based specialized computer that carry out control functions of various machines and processes [1]. In mobile robot development, there are few research works using PLC as the mobile robot controller. Also, for educational and research purpose, a low cost mobile robot platform is widely used and usually controlled by some kind of microcontroller or PC interface cards [6]. However these platforms are not usually composed by industrial of the ledge resolutions. Thus, PLC has been introduced as industrial component based mobile robot system.

PLC is a unique form of microprocessor-based controller that uses programmable memory to store instructions and to implement functions such as logic, sequence, timing, counting and arithmetic in order to control machines and processes [7]. A distance PLC programming course employing a remote laboratory based on a flexible manufacturing cell has been proposed [8]. The control system used in the study is PLC (Modicon TSX Micro, supplied by Schneider Electric, Barcelona, Spain). Even though this project used PLC from

Keyence KV-series but the system is same where each station has its own PLC and controls the manufacturing/platform sequence and communicates with the others.

## III. OVERALL PROJECT FLOW

In order to develop program for a good system, the controller itself needs to be studied and the system need to be understood before start the programming. As mention by [7], PLC is similar to computer, but as computers are optimized for calculation and display tasks, PLCs are optimized for control tasks and industrial environment. Thus;

- PLCs are rugged and designed to withstand vibrations, temperature, humidity, and noise.
- PLCs have interfacing for inputs and outputs readily inside the controller.
- PLCs are easily programmed and have an easily understood programming language that is primarily concerned with logic and switching operations.

The type used in this project is ladder diagram and the PLC hardware that is used as controller of mobile robot is Keyence PLC KV-16T. Figure 1 represent the overall flow for the project development.

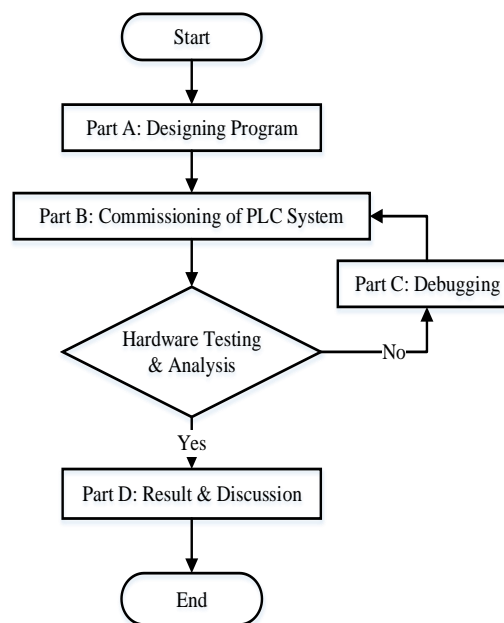

Figure 1: Overall project flow

## IV. PROGRAM DESIGN

Part A is where the program is developed. Starting from inputs & outputs specification, algorithm preparation and transfer into software for debugging and testing before communicate it to the mobile robot. Table 1 and 2 describe the inputs, outputs that have been used in the project. The input components are start button, stop button, emergency button and sensors. Meanwhile, the outputs are relays which employed as safety switch to motor and indicator lamps. This input and output assignment will help the development and implementation of ladder diagram to become easier. The tables also show the address of each input and output components that

attached to controller and pseudo code. The function of each component is explained in the ‘Remarks’ column.

Table 1  
Input assignment

No.	Input	Address for controller	Address for pseudocode	Remarks
1	Start Button	0000	Start_B	Start
2	Sensor 1	0003	S_Left	Left Sensor
3	Sensor 2	0004	S_Middle	Middle Sensor
4	Sensor 3	0005	S_Right	Right Sensor

Table 2  
Output assignment

No.	Output	Address for controller	Address for pseudocode	Remarks
1	Relay 1	0500	F_Left	Left motor forward
2	Relay 2	0501	R_Left	Left motor Reverse
3	Relay 3	0502	F_Right	Right motor forward
4	Relay 4	0503	R_Right	Right motor reverse
5	Green Indicator	0504	Lamp_1	System ON
6	Orange Indicator	0505	Lamp_2	System OFF

Programming algorithm using a pseudocode helps to construct flowchart much easier. Pseudocode means a type of structured English for describing algorithms. It describes the entire logic of the algorithm so that implementation becomes a rote mechanical task of translating line by line into source code. The developed pseudocode for this project is shown in Figure 2.

After the algorithm has been developed, it will be translated into Boolean algebra in order to build PLC programming much easier and to avoid confusion between the results. For Boolean equation, it is divided into 4 parts which are for 4 relays; left motor forward and reverse movement and right motor also for forward and reverse. Before that, it is recommended to construct a truth table to avoid taking non-used binary number such as shown in Table 3, where those item in the red box is the only binary number that will be used in the program. Take note, the truth table will not be included with the start button because it is manually operated by user and start button need to be constantly switch ON in order for the robot to be activated.

Table 3  
Truth table for input and output

Input			Output			
S_Left	S_Middle	S_Right	Left Motor		Right Motor	
A	B	C	Forward, R1	Reverse, R2	Forward, R3	Reverse, R4
0	0	0	0	0	0	0
0	0	1	1	0	0	1
0	1	0	1	0	1	0
0	1	1	0	1	1	0
1	0	0	0	1	1	0
1	0	1	0	0	0	0
1	1	0	1	0	0	1
1	1	1	0	0	0	0

```

If Start_B
Do Lamp_1
Else
If Stop_B OR Emerge_B
Do Lamp_2
End If

While Start_B
If S_Middle
Do F_Left
Do F_Right
Else
If S_Left
Do F_Right
Do R_Left
Else
If S_Right
Do F_Left
Do R_Right
Else
If S_Middle AND S_Left
Do F_Left
Do R_Right
Else
If S_Middle AND S_Right
Do F_Right
Do R_Left

Else
If S_Middle AND S_Left AND S_Right
Do Lamp_2
Endwhile
    
```

Figure 2: The pseudocode

Thus, the Boolean equation can be built by extracting the red box using symbol A, B, C, R1, R2, R3 and R4, as shown in Equation 1 until 4.

$$\bar{A}\bar{B}C + A\bar{B}C + AB\bar{C} = R1 \tag{1}$$

$$\bar{A}BC + A\bar{B}\bar{C} = R2 \tag{2}$$

$$\bar{A}B\bar{C} + \bar{A}BC + A\bar{B}\bar{C} = R3 \tag{3}$$

$$\bar{A}\bar{B}C + AB\bar{C} = R4 \tag{4}$$

V. SIMULATION OF PROGRAMMING

The program simulation is developed using KV Ladder Builder by KEYENCE Corporation. By using the same algorithm as explained previously, the program and simulation can be done without transferring into mobile robot.

This section is discussing the wiring circuit that is used in in order for the mobile robot to be able to operate using PLC system. The wiring circuit as shown in Figure 3 consists of 4 inputs which are push button and 3 sensors. Meanwhile the output is connected with 2 relays as safety switch for both left and right motor. In addition, 2 relays are added to make the motor able to rotate in forward and reverse direction. There are also another 2 output functions of light indicator as to monitor the system functionality.

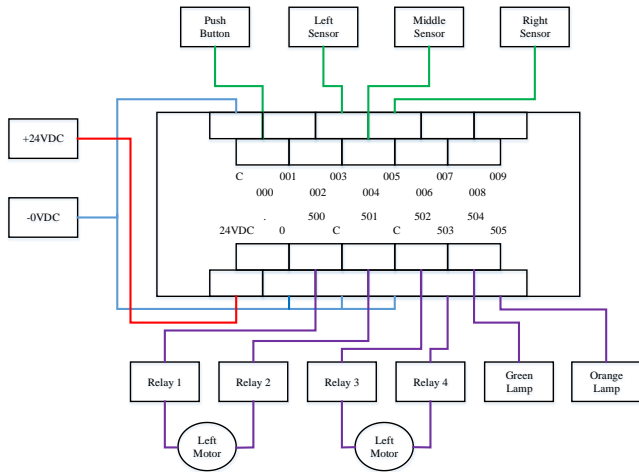

Figure 3: Wiring diagram for PLC keyence KV16T

VI. COMMISSIONING OF PLC SYSTEM INTO MOBILE ROBOT

The analysis will be done by measuring the constant variables to illustrates the movement of the mobile robot and at the same time analyze the effectiveness of the developed system. Actual path (a) and Line graph (b) on Figure 4 show the enlarged image of actual path during experiments and its illustration of the relationship between the actual path and data presentation in line graph. The upper limit is 2.3cm meanwhile the lower limit is -2.3cm. The targeted path is 0cm which is the center of the line.

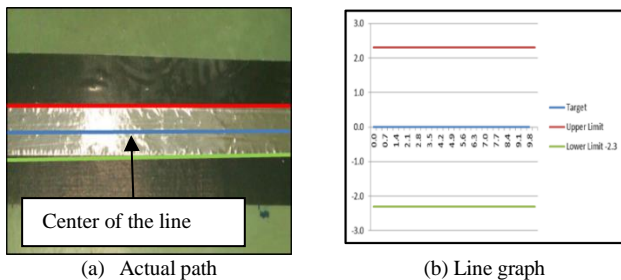

Figure 4: The relationship of actual path and line graph for data analysis

As the actual path is obtained, the result is compared with the targeted or theoretically result and a table of error data recorded will be displayed as data tabulation to construct the line graph. It consists of distance and width of the path which the distance of the path will be the point to measure the error and the width show the targeted, upper limit and lower limit of the movement. The result is the actual path that the mobile robot took during experiment. Meanwhile, the line graph is to represent the data of the movement error. The line includes with the mobile robot starting and ending point and the path direction flow for the mobile robot to move. The pathway route will be silver/black line to enable the mobile robot sensor to detect the path while responding to the mobile robot's programmed. For the experiment setup, procedure and variables is written in [10].

VII. EXPERIMENT RESULT AND DISCUSSION

Figure 5 is the full result for navigation experiment: straight line. The result in Figure 5 is the summary of 5 results shows in [10]. Meanwhile, Figure 6 is the full result for navigation experiment: U shape line. It consist all 5 runs that has been done according to plan. From what is observed through both figures, the red box indicates the upper and lower limit data recorded by the mobile robot during the five runs test. Compare with straight line result in [10], the mobile robot movement in U-shape line is not as stable as movement in straight line. A problem occurred during turning point which can be seen in Figure 6 where the quantity of the point exceeding the upper and lower limit is large. From figures, it can be observed, the percentage of error for overall result in U-shape line is 10% which, double the error percentage in straight line. Although, the movement of the robot during navigating on the straight line is not "really straight", it is still considered of success navigation since most of the time the robot is able to move in the limit range.

This proved that mobile robot is able to navigate based on PLC controller with the help of sensory data to identify the path. However, a precise control of the navigation would be better to help the robot to move in rather smooth movement. This would be the next challenge in order to produce an intelligent PLC based mobile robot. The robot movement in the navigation experiment for U shape line can be considered as good although the results shows that the robot movement is not always at the center point, but towards the left and right of the center point.

However, most of the times the recorded displacement errors are still within the limit of the silver tape width. Anyway at certain points, the error is exceeding the limit and these situations mainly occurred at the turning points of the U- shape pathway. A few causes could be considered due to this problem such as the speed of the robot is too fast that cause the robot overshoot of the path, or the number of sensors should be increased so that the line detection process can be more precise. A deep investigation on this problem would be necessary to ensure for a smooth and better movement in the robot navigation.

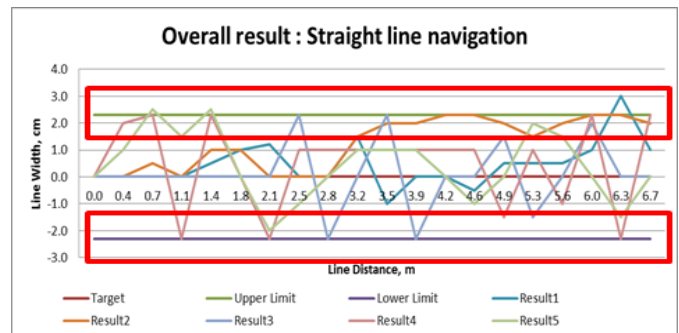

Figure 5: Line Graph for Straight Line Navigation

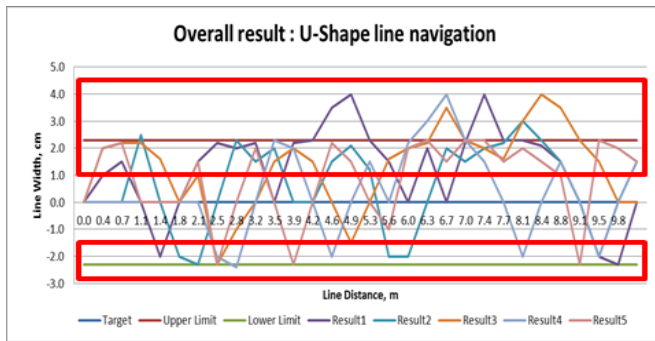

Figure 6: Line Graph for U-Shape Line Navigation

### VIII. CONCLUSION

This project describes an application of PLC as controller to move mobile robot. The ultimate goal of this project is to move mobile robot using PLC programming and the specific objectives that need to be achieved are first to design and develop PLC based controller system for mobile robot. Second objective is to analyze the effectiveness of the developed system through a series of movement performance experiments of the mobile robot. Thus, this paper contains all detail that is needed to fulfill the objectives.

At the end of the project, all objectives are achieved where the ultimate goal has been completely done by moving mobile robot using PLC based controller and enable the mobile robot to read and follow the line. The system has been designed using Keyence Ladder builder to creates a programming language and the controller has been develop using PLC Keyence KV16T including all wiring with relays and other outputs to ensure the mobile robot able to move and follow the line.

As for future works, there are few suggestions that can be proposed as to improve this project in better way. Firstly, for a better functionality, a sensor to detect obstacle should be added, so that the robot is able to avoid object or wall while moving around. Second suggestion, is to use an encoder DC motor as to have ability in controlling the speed. There are a lot of advantages in controlling the speed of DC motor using Programmable Logic Controller such as decreasing the control panel sized, consumption of low energy and durable equipment

thus give term of sustainability [9]. Because of DC motor are regulated in a general range of speeds thus using this type of motor in this project give quite challenge to control the sensitivity of the sensor but DC motor has ability to control the speed and angle of the motor.

### ACKNOWLEDGMENT

First of all, thanks to Allah for allowing us to finish this paper. We would like to thank Universiti Teknikal Malaysia Melaka for giving us the opportunity to develop this study. Thanks to fellow friends to support us unconditionally. Lastly, Special thanks to Zamalah, UTeM for funding this research and grant scheme FRGS/1/2015/TK03/FKP/02/F00277.

### REFERENCES

- [1] Kothari, Rohit Girme and Abhijeet Khedekar and Vishwajit Walke and Arpit, "PLC Based SMS Controlled Robotic Arm. 7", 2007.
- [2] Greenwald and Kopena, "Mobile Robot Labs", *IEEE Robotics and Automation Magazine*, 2013, Vol. 10, Issue: 2, pp.4-6.
- [3] C. Carderia and J. Costa, "A Low Cost Mobile Robot for Engineering Education", Proceedings of 32<sup>nd</sup> Annual Conference of *IEEE Industrial Electronics Society*, 2005, pp. 2162-2167.
- [4] Roland Siegart and Illah R. Nourbakhsh, "Introduction to Autonomous Mobile Robot", 2014.
- [5] A. M. Ahmad, A. A. Ayman and A. S. Farhan, "Mechatronics Design of a Mobile Robot System", *I.J. Intelligent Systems and Applications*, 2013, pp.23-36.
- [6] Hugo Freitas and Pedro Vilela and Mario Ramalho and Carlos Cardeira and Rui Loureiro and Jorge Bengala, "An Industrial Automated Guided Robot", 2005.
- [7] W. Bolton, "Programmable Logic Controller", *Newnes*, 2009.
- [8] O. G. Bellmunt, "A Distance PLC Programming Course Employing a Remote Laboratory Based on a Flexible Manufacturing Cell", *IEEE Transaction On Education*, 2006, Vol. 2, No: 49.
- [9] A. Parviz, B. Mahsa, "Speed Control by DC Motor Using Programmable Logic Controller with High Accuracy", *Universal Journal of Control and Automation*, 2013, pp.91-97
- [10] S. Saffar, F. A. Jafar and S. A. Idris, "Navigation Method of PLC Based Mobile Robot", *Ubiquitous Robots and Ambient Intelligence (URAI)*, 12th International Conference on, Goyang, 2015, pp. 507-511.
- [11] Y. M. Ahmed, O. Yaakob, B. K. Sun, "Design of a New Low Cost ROV Vehicle", *Jurnal Teknologi*, 2014, Vol. 7, No: 69, pp. 27-32.
- [12] A. A. B. Hisham, et al., "Mobile Inspection Robot for Heating, Ventilation and Air Conditioning (HVAC) Ducting Systems", *Jurnal Teknologi*, 2014, Vol. 6, No: 73, pp. 89-93.