

SECURITY SYSTEM USING CONTROLLER AREA NETWORK (CAN) BUS

Mazran E., Redzuan A.M., Badrul H.A., Adie M. K, Amat A.B.

Faculty of Electronic and Computer Engineering
Universiti Teknikal Malaysia Melaka

mazran@utem.edu.my, redzuan@utem.edu.my,
badrulhisham@utem.edu.my, adie@utem.edu.my, amat@utem.edu.my

Abstract

Controller Area Network (CAN) has long been used for automotive applications as a method to enable robust serial communication. The goal was to make the system more reliable, safe and efficient while decreasing wiring harness weight and complexity. Based on these factors, a CAN bus project was carried out to fully utilize the application of CAN bus system in building automation, security system and data acquisition system. This report shall focus on application of CAN bus in security system

Keywords: CAN Bus, data acquisition, security system, serial communication.

I. INTRODUCTION

The project was initiated through short term grant research project at Universiti Teknikal Malaysia Melaka (UTeM). Among the purpose of this project is to improve the current communication strategy in control and data acquisition system, building automation and security system. This system will apply the use of two wire system from CAN protocol to interconnect between control terminals. There will be several nodes designed in the system including the main controller, keypad module, zone alarm module, door strike module and a few others. Each node or module will consists of its own controller and CAN transceiver. The communication between the nodes and controller will make use of the CAN bus protocol

II. LITERATURE REVIEW

There are two types of communication system used in security and control system industries which are Field bus Control System and Distributed Control System. Among these two systems, the Field bus control system is a solution of process control with advantages in standardization in network communication. It has simpler structure, higher accuracy and higher anti disturbance capability than the distributed control system. For a large number of components, field bus control system has more advantage compared to distributed control system. Controller Area Network (CAN) bus is one of the Field bus control system type used in decentralization, intelligence and networking.

CAN protocol have been designed by Robert Bosch in 1986 for automotive applications as a method to provide a robust serial communication. The goal was to make automobiles more reliable, safe and fuel-efficient while decreasing wiring harness weight and complexity. Having all these advantages, the use of CAN bus in the security system is an added value to the system and increase its reliability.

The purpose of using CAN bus is to enable any station to communicate with other station without putting to much load to the main controller. This opens the opportunity in development of intelligent ubiquitous sensor network and controller system.

CAN bus is a fast serial bus that is designed to provide an efficient, reliable and economical link between various CAN stations, sensors and actuators. The requirement for the information exchange has grown to such an extent that a cable network with a length of up to several miles and many connectors were required. This will increase the problems concerning material cost, production time and reliability.

This paper will explain the overview of CAN bus system, design method of security system using CAN Bus protocol, system hardware, software and the result.

III. OBJECTIVES

The research and development of this project was driven by robustness of the CAN communication and its practicality of application. Therefore, the completion of this project is expected to fulfill the following objectives:

1. To apply a CAN bus system in control and data acquisition system in industry.
2. To build a model of a system utilizing CAN Bus protocol.
3. To utilize the capabilities of a CAN communication as well as the network system
4. To design and develop a new security system based on the implementation of CAN Bus communication.

IV. HARDWARE

This security system is developed with CAN bus module designed as a general purpose controller. This same module can be placed at any point in any system that requires a controller and communication between controllers.

This project is focussed in designing a CAN bus system module at the discrete

component level where all the circuitry are designed and fabricated. Each of the module are similar except the application of such module will be different. Extra circuits may be required to tailor the need of each station. General block diagram for the CAN bus system is as shown in the figure 1 below:

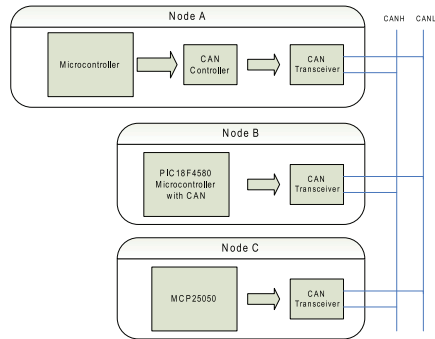

Figure 1: General Block Diagram of CAN bus system

Each of the nodes consists of a microcontroller, CAN Controller and CAN Transceiver.

In a CAN bus system, a CAN transceiver plays a significant role in determining a successful data transmission over the can bus terminal. Figure 2 shows the circuit connections for CAN Transceiver MCP2551 and CAN Controller MCP2510/15

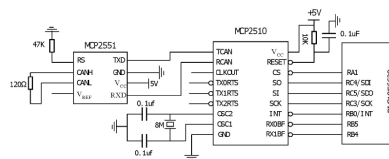

Figure 2: CAN controller and CAN Transceiver Connection

CAN transceiver is required to shift the voltage levels of the microcontroller to those appropriate for the CAN bus. This will help to create the differential signal CAN High and CAN Low which are needed in CAN bus. This device must be able to withstand voltage tolerance which may be caused by noise pickup. This is to protect itself and the interfaced microcontroller. It is more efficient to

replace a faulty CAN transceiver than to replace the whole microcontroller. There are many manufacturers that produce CAN transceiver. They are slightly different in characteristic but all are complies with the requirement of ISO11898 Standard for CAN bus and serves the same purpose.

CAN bus require only 2 wires to connect to other nodes. These wires are the CANH and CANL. Each of the nodes are connected to the main has both the CAN Controller and CAN transceiver.

This is not the only way of implementing the CAN bus system with the microcontroller. Microchip has manufactured microcontrollers with embedded CAN controller. This has reduced the number of ICs that has to be placed in the circuit and thus simplify the circuit for each of the module. Most of these microcontrollers are the 16 bit 18 series PIC microcontrollers.

Not all of the nodes may be used for complex functions and algorithms. Therefore to reduce the development cost and increase the system integrity, a node can consists of an MCP25050 chip which is manufactured for CAN bus system for simple input output application. The MCP25050 is cheaper than the PIC 18 series microcontroller with CAN system.

The security system is developed using the principles and theories described above. Figure 3 shows the block diagram of security system. The same pattern of block diagram discussed earlier in figure 1 is implemented here in figure 3 except that this one only shows more general overview of the hardware.

The overall security system is based on the integration several subsystems. There are several considerations which are required in the construction of a security system. First is the design Main Controller Unit where it is responsible to monitor the secure premises, control the operation of the overall system, indicate

zone status and authorize legal entries as well as to trigger the alarm. The design requires a +5V to drive to microcontroller and indicator circuit while a +12V supply is used to drive the Alarm Unit, power connected nodes, activate the door solenoid as well as monitor the sensor network. Both voltage supplies are rated at 1A maximum. The design includes a backup battery supply with an onboard trickle-charger to provide a constant 13.85V to charge any 12V sealed lead acid battery. However, a 7AH battery is recommended to power the overall security system in case of power failure. A fully charged battery can last up to approximately 13 hours at minimum power consumption.

Besides the main controller, there are 3 other nodes designed in the system as shown in Figure 3. The Keypad Node is a module used to interface the Primary Base Terminal with a 4x4 matrix keypad. The matched module is responsible to accept key press entries which is then transmitted via CAN Bus to the Main Control Unit. Received data is then compared with related codes (either pass code or master code) before it replies with a certain address and 64-bit data pattern. Related nodes will then respond accordingly to the received data.

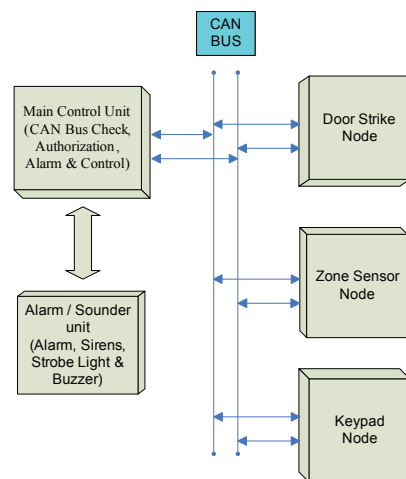

Figure 3: Security System block Diagram

As for the Door Strike node, it is used for

acceptance response, solenoid actuation, CAN Bus check responds, and zone break-in detector. Zone check selector switch is used to set the node only to respond to specific address request.

The Zone Sensor node is very similar in design to the Door Strike node, except that it is built without the door strike actuator. The module is used for acceptance response, CAN Bus check responds, zone break-in detector and an extra indicator LED.

The final part of the security system is the Alarm or Sounder Unit. This unit is used to house alarm and indicator devices such as main siren, strobe light, and buzzer. The triggering of the alarm unit is directly controlled by the Main Control Unit. The unit design incorporates an anti-temper circuitry counter any unauthorized attempt to open, modify or disconnect the unit and has its own internal connected backup battery. Figure 5 shows the overall hardware block diagram of the security system.

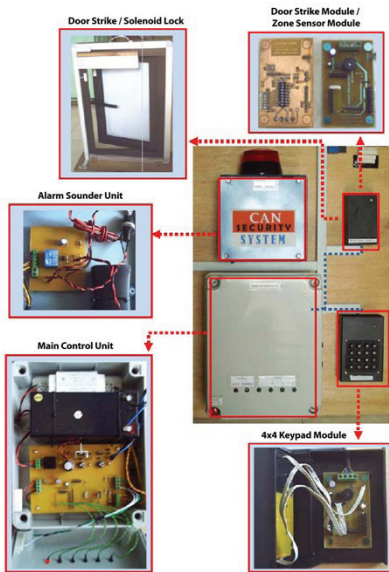

Figure 4: Security System Using CAN bus

V. SOFTWARE

In order for the hardware to function, the firmware code for the system has to be written. Theoretically, software that resides in the non-volatile memory and handles the operation as well as function of a system is known as firmware. The firmware holds the information that the Microcontroller needs to operate or run. Thus, it needs to be free of bugs and errors for a successful application or product. There are various types of software that could be used to program a PIC micro. Program can be written in a variety of languages such as C, Basic, Pascal or even Assembler. In this project, the program would be written in C language to generate the required firmware for the system.

The program code is written in C language using CCS C compiler (by Custom Computer Services) to generate the hex file. This hex file is then downloaded into the microcontroller for it to function as programmed. There are several advantages of using CCS as the compiler because functions related to CAN system are already available and ready to be used. This reduces the time to write the program code as well as ease the development process.

The CAN protocol supports two message frame formats. The "CAN base frame" supports a length of 11 bits for the identifier, and the "CAN extended frame" supports a length of 29 bits for the identifier [8]. Figure 5 below shows the standard 11 bit identifier format.



Figure 5: CAN Standard 11 bit identifier

Based on the CAN Standard being used either standard or extended format, the data being transmitted or received through the CAN bus has to be programmed according to the protocol. Figure 6 shows an example of flowchart to receive CAN signal from CAN bus by any node in the

system.

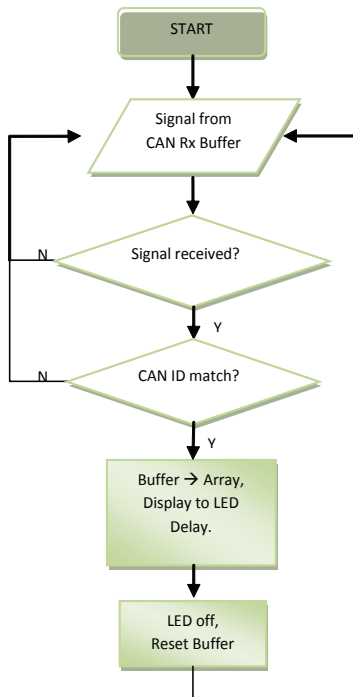

Figure 6: Example Flowchart of the Receiver Program.

VI. RESULTS & DISCUSSION

Figure 7 shows the Mixed Signal Oscilloscope (MSO) output of CAN signal and RS232 signal. This is used to verify CAN data and estimate the CAN timing. Note the vertical dotted lines are the start point and endpoint of the measured CAN message signal.

In terms of functionality, the security system manage to perform as expected plus some added advantage of CAN Bus system being implemented. The distributed processing from different component performed by different nodes reduces the load of the main controller thus increase the system performance. This is achieved from the use of keypad module, door strike node and zone sensor node where each of the nodes has its own controller or its own CAN Module.

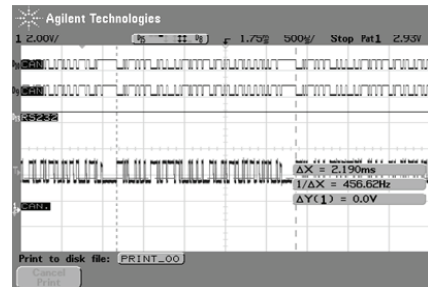

Figure 7: MSO output of CAN activity.

VII. ACKNOWLEDGMENT

The author would like to express his gratitude to Universiti Teknikal Malaysia Melaka for the sponsorship of the project through the Short Term Grant (STG) scheme.

VIII. REFERENCES

- Bosch, R. 1991. CAN Specification Version 2.0. Postfach: Bosch GmbH 34-68.
- Pazul, K. 2005. AN713: Controller Area Network (CAN) Basics. [Online] Available: <http://ww1.microchip.com/downloads/en/AppNotes/00713a.pdf>
- CCS. (2007). C Compiler Reference Manual Ver. 4. [Online] Available: http://www.ccsinfo.com/downloads/ccs_c_manual.pdf
- Richards, P. 2005. AN754: Understanding Microchip's CAN Module Bit Timing. Available: <http://ww1.microchip.com/downloads/en/AppNotes/00754.pdf>
- Thomas, P. 1994. The Alarm, Sensor & Security Circuit Cookbook. New York: McGraw-Hill, Inc.

- Masahiro A. 2008. Crime prevention assisting apparatus and radio terminal apparatus. U.S. Patent 6,127,924.
- Brian K. C. 1996. Local Alarm System Tamper Protection Device. U. S. Patent 5,519,756.
- Norman, T . 1994 Integrated Security Systems Design: Concepts, Specifications, and Implementation. Oxford: Butterworth-Heinemann. 21-34;
- Robert, C. E., Toby, J. V. 2001 Build Your Own Smart Home. California: McGraw-Hill, Inc. 74- 124;
- Petruzzellis, T. 1994. The Alarm, Sensor & Security Circuit Cookbook. New York: McGraw-Hill, Inc. 133-274;
- Honey, G. 2003. Intruder Alarms. 2nd. Edition Oxford:Newnes. 33-92;
- Gubel, C. 2004 AN916: Comparing CAN and ECAN Modules. [Online] Retrieved 07, October 2007, Available: <http://ww1.microchp.com/downloads/en/AppNotes/00916a.pdf>. 2005. 1-7;
- Gardner, N. 2002. PIC C: An Introduction to Programming the Microchp PIC in C. London: Character Press Ltd. 7- 13;
- Microchip. 2007. DS39625C: PIC18F2585/2680/4585/4680Data Sheet. Available: <http://ww1.microchip.com/downloads/en/DeviceDoc/39625c.pdf>. 2-341;
- Iovine, J. 2004 Pic Robotics - A Beginner's guide to Robotic. 3rd. Edition. McGraw-Hill. 4-5.
- Maki, M.C., Newcomb, I.A. and Robotham, J.W. 1998. Cost effective security system integration, Proceedings EEE 32nd Annual 1998 International Carnahan Conference on Security Technology, Alexandria, Virginia, pp. 140- 146.
- Renjun Li, Chu Liu and Feng Luo, 2008. A Design for Automotive CAN Bus Monitoring System, IEEE Vehicle Power and Propulsion Conference (VPPC), September 3-5, Harbin, China
- Hui Guo, Ying Jiang. 2006. Application Layer Definition and Analyses of Controller Area Network Bus for WireHarnessAssemblyMachine, International Conference on Computational Intelligence for Modelling Control and Automation, and International Conference on Intelligent Agents, Web Technologies and Internet Commerce (CIMCA-IAWTIC'06) 0-7695-2731-0/06,
- Fang Li, Lifang Wang, Chenglin Liao, CAN(Controller Area Network) Bus Communication System Based on Matlab/Simulink. Available : <http://www.ieeexplore.ieee.org> .
- Xia Dong, Kedian Wang, Kai Zhao. 2008. Design and Implementation of an Automatic Weighing System Based on CAN Bus. International Conference on Advanced Intelligent Mechatronics. July 2 - 5, Xi'an, China
- Chen Yueping, Gan Fangcheng, Zhang Yongxian. 2007. Design and Realization of Fire Alarm System Based on CAN Bus. The Eighth International Conference on Electronic Measurement and Instruments, ICEMI'.

Algimantas Valinevicius, Mindaugas
Zilyys, Danielius Eidukas. 2004.
Information Flow Model of
Integrated Security System.
26th Int. Conf. Informafion
Technology Interfaces IT/ 2004, ,
Cavtat, Croatia

