

# Simulation Analysis on the Potential Application of Matched Bandstop to Bandpass Filter in Filter Integrated SPDT Switch Design

A. M. Zobilah<sup>1</sup>, N. A. Shairi<sup>1</sup>, Z. Zakaria<sup>1</sup>, B. H. Ahmad<sup>1</sup>, M. K. Zahari<sup>1</sup>, P. W. Wong<sup>2</sup>

<sup>1</sup>Microwave Research Group (MRG), Centre for Telecommunication Research & Innovation (CeTRI), Faculty of Electronic and Computer Engineering (FKEKK), Universiti Teknikal Malaysia Melaka (UTeM), Hang Tuah Jaya, 76100, Durian Tunggal, Melaka, Malaysia.

<sup>2</sup>Electrical & Electronic Engineering Department, Universiti Teknologi Petronas (UTP), Bandar Seri Iskandar, 31750 Tronoh, Perak, Malaysia.

noorazwan@utem.edu.my

**Abstract**—This paper presents the simulation analysis on the potential application of matched bandstop to bandpass filter in filter integrated switch (FIS) design. The FIS consists of matched band-stop to bandpass filter integrated with single-pole-double-throw (SPDT) switch. The proposed design was demonstrated for 2.45 GHz applications in wireless data communication systems such as Bluetooth and Zigbee. The filter was based on L-shape lossy resonator, which can provide an absorptive feature. PIN diodes were used as switching elements for the SPDT switch and to reconfigure between band-stop and bandpass responses. Therefore, the key advantages of the proposed design are high isolation and good return loss at both ON- and OFF-state ports. As a result, the simulation showed the followings: higher than 10 dB of return loss and greater than 25 dB of isolation at the operation frequency.

**Index Terms**—Filter Integrated Switch; Single Pole Double Throw; Bandstop to Bandpass; Switchable Filter.

## I. INTRODUCTION

Integrating multiple devices into one is an effective method to reduce circuit size, mismatching loss, and fabrication cost. Radiofrequency (RF) and microwave device with integrated-filter have become a popular design concept in the recent years, i.e., amplifier integrated with RF switch [1], integrated-filter antenna [2], and power amplifier integrated with modulator [3].

Filter-integrated switch, as depicted in Figure 1 is another multifunction device. Since 2006, many efforts have been done to develop filter-integrated SPDT switch [4]–[15], SPST switch [16]–[18] or DPDT switch [19]. In order to realise filter-integrated switches (FISs), several techniques have been proposed, i.e., FET loaded quarter-wave length bandpass filter [16], PIN diode loaded stepped-impedance resonators [7], quarter-wavelength [13], quasi-lumped element [14], inductor parallel to the PIN diode [11], PIN diode connected to half-wavelength hairpin resonator [19], and PIN diode with coupled microstrip line [4], [6].

However, all of the previously mentioned FISs, suffer from different issues. Many of them were proposed in MMIC circuits [5], [8]–[10], [12], [15], [17], [18]. While MMICs allow for most compact designs, conventional planar circuits exhibit a greater flexibility at lower cost. Additionally, the proposed design in [16] mainly focused on

designing the performance around the passbands, which means that only the on-state filter response and off-state isolation in the vicinity of the centre frequency were considered. The reported filter-integrated switches suffer from the high insertion loss [7] and large size [6], [7] due to the need for high-order bandpass filters (BPFs) and long electrical length of a quarter-wavelength transmission line, respectively.

Unfortunately, most of these studies [5]–[12], [14]–[19] have a problem of extremely low return loss at the ports that are not switched to the antenna, called as OFF-state ports. The low return loss is caused by a reflection of an incoming signal back to the source. This problem needs to be solved as there may be some applications that require good Voltage Standing Wave Ratio (VSWR) for all operating ports. As the solution for this problem, an absorptive feature in filter integrated switches was introduced in [13], but required additional switch elements and 50  $\Omega$  resistors.

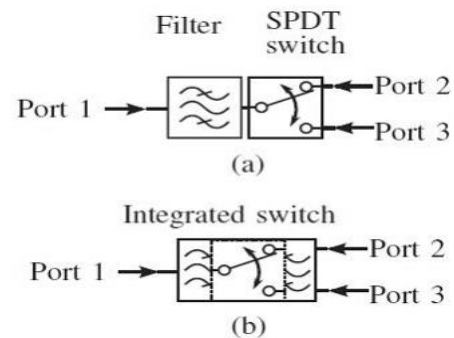

Figure 1: Conventional (a) filter and switch, (b) integrated filter and switch [4].

Therefore, this paper presents the potential application of switchable matched band-stop to bandpass filter based on L-shape lossy resonator [20] in filter-integrated SPDT switch design. The performance of the proposed design was based on the simulation analysis such as insertion loss, return loss and isolation.

Based on literatures, [21] reported the overview of matched band-stop filters and the L-shape lossy resonator was used in matched bandstop filter design [22] and absorptive SPDT switch [23]–[24]. Thus, the use of L-shape lossy resonator can provide an absorptive feature for the

filter-integrated SPDT switch without the need for additional elements if compared with [13]. In addition, the proposed integrated SPDT switch with switchable matched band-stop to bandpass filter results in many benefits such as eliminating out-of-band signals and filtering out the spurious signal. Also, the integrating of switchable matched band-stop to bandpass filter with SPDT switch will result in a system miniaturisation and reduction of insertion loss.

II. THEORY AND METHODOLOGY

A. Matched Band-stop Filter

Chang and Hsieh reported in 2004 that planar technologies such as micro-strip technology suffers from low-Q factor compared to the non-planar technologies, such as coaxial and rectangular. This makes it difficult for a lossy resonator having a low-Q factor to achieve high notch depth and selectivity of band-stop filters. However, in [25], a perfectly infinite stopband attenuation of the matched band-stop was shown, where high notch depth and selectivity can be achieved by using two lossy low-Q resonators in micro-strip technology. This idea was taken from [26] that built upon the perfectly-notch concept, where it consists two identical lossy resonators connected to the 90° hybrid coupler or directional coupler, as shown in Figure 2. This technique enables the use of two low-Q lossy resonators for high attenuation of band-stop filter applications. Therefore, its advantages are producing higher stopband attenuation and being perfectly matched in both the passband and stopband.

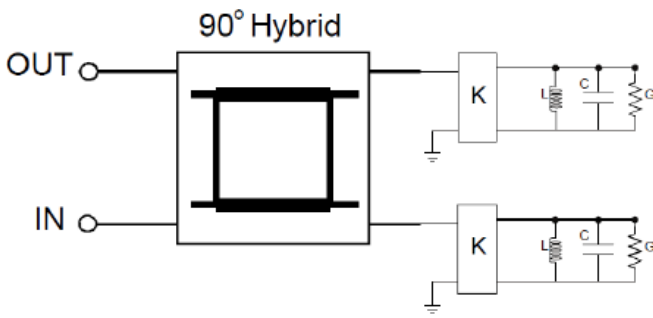

Figure 2: Hybrid circuit implementation of a perfectly-matched notch filter [22]

Referring to [22], a symmetrical two-port network is defined by even-mode  $Y_e$  and odd-mode  $Y_o$  admittances. The S-parameters are given by:

$$S_{11} = S_{22} = \frac{1 - Y_e Y_o}{(Y_o + 1)(Y_e + 1)}$$

$$S_{12} = S_{21} = \frac{Y_o - Y_e}{(Y_o + 1)(Y_e + 1)}$$

Then, if  $Y_o=1/Y_e$  for all frequencies, then  $|S_{11}|=0$  for all frequencies, and the network possesses the all-pass property. If  $Y_o=Y_e$  at a certain frequency, then  $|S_{12}|=0$ , and the network produces infinite attenuation at that frequency.

Figure 3 shows the generalised coupled-resonator model of a matched notch filter. The model has a symmetrical of the two-port network, which consists of two identical resonators coupled to each other and produces match band-stop response.

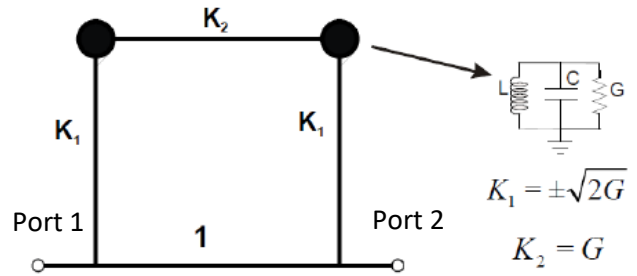

Figure 3: Generalized coupled-resonator model of a matched notch filter [22]

B. Filter-Integrated SPDT Switch

Figure 4 shows the diagram of the proposed absorptive filter-integrated SPDT switch. For illustration, four resonators (S1, S2, S3, & S4) were used to obtain filter and switch performance for 2.45 GHz applications. The resonators of S1 and S4 were coupled line L-resonators assigned to act like bandpass and band-stop filter at 2.45 GHz, while the resonators of S2 and S3 were transmission line stub resonators being used to achieve higher isolation performance. In general, the circuit was designed in order to switch between different modes, transmitter (Tx) and receiver (Rx) modes and to filter the transmitted or received signals. To do so, shunt and series PIN diodes (D1 to D8) were used. Several biasing circuits (Vbias 1 - Vbias 4) were utilized to control the PIN diodes. To obtain a high-pass response, 10 pF was chosen as the value of the DC block (C). On the other hand, to block RF signals at 2.45 GHz, the chosen value of the RF choke (L) was 10 nH

In this part, the FIS circuit operation during transmitter (Tx) mode will be discussed due to the symmetrically structure of the FIS circuit. Thus, as illustrated in Figure 4, the RF signals propagated from the transmitter (Tx) to the Antenna during transmitter (Tx) mode operation. In this case, series PIN diode D4 was turned ON, while shunt PIN diodes (D1, D2, & D3) in the transmitter (Tx) arm were turned OFF with voltage control (-5 V). Hence, the coupled line L-resonator S1 acted as bandpass filter. Subsequently, the transmission line open stub resonator S2 created the all-pass response. In contrast, series PIN diode D5 was turned OFF, while shunt PIN diodes in the receiver (Rx) arm (D6, D7, & D8) were turned ON with voltage control (+5 V). Therefore, the coupled line L-resonator S4 and transmission line open stub resonator S3 acted like the band-stop filter.

To illustrate this operation, the created band-stop response in the receiver (Rx) arm was responsible for the isolation between the transmitter (Tx) and receiver (Rx), and the created bandpass response in (Tx) was

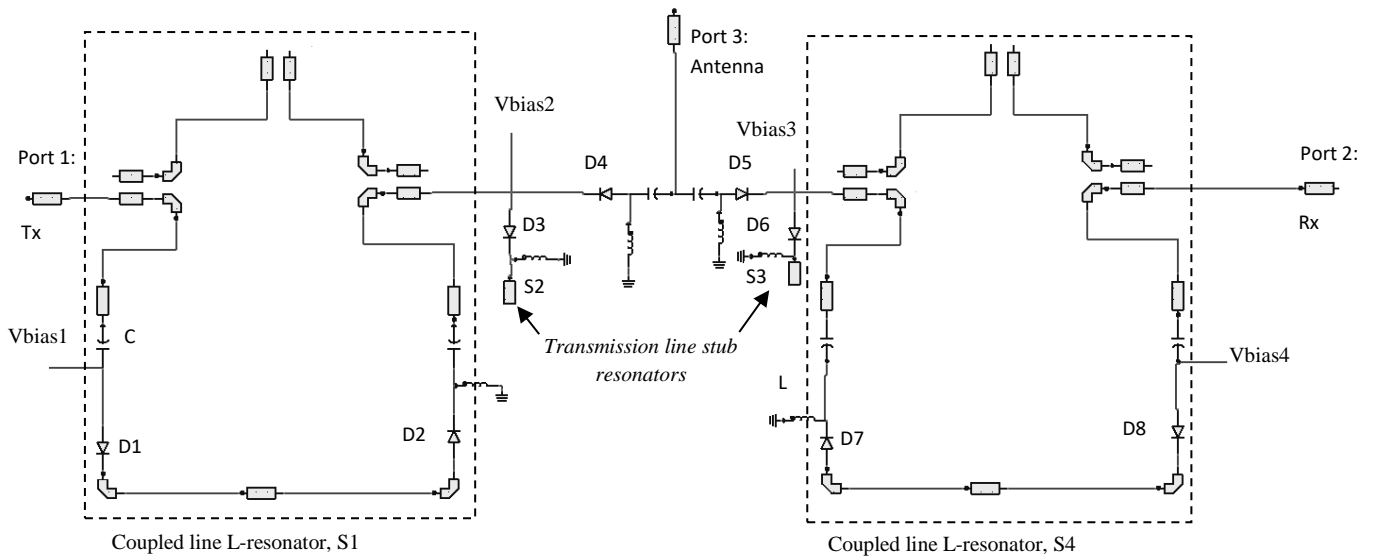

Figure 4: Circuit diagram of an absorptive filter integrated SPDT switch

responsible for filtering the signals. Table I presents the summary of the process in the receiver (Rx) and transmitter (Tx) modes of the proposed absorptive filter integrated SPDT switch at 2.45 GHz.

### III. SIMULATION RESULT OF FILTER-INTEGRATED SPDT SWITCH

Figure 5 illustrates the layout of the proposed absorptive filter-integrated SPDT switch for 2.45 GHz applications. The total layout area of the proposed design was 99.8 mm x 48.5 mm.

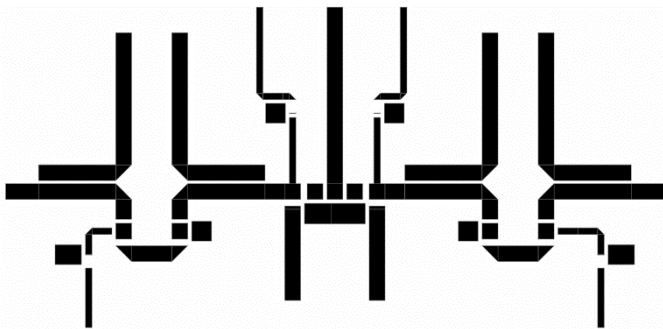

Figure 5: The layout of the absorptive filter-integrated SPDT switch

Figure 6 presents the simulation results of the proposed absorptive filter-integrated SPDT switch. The simulated results were as follows; insertion loss, return loss, and isolation.

It can be clearly seen that the isolation performance (S12) of the design achieved more than 50 dB at the operation frequency (2.45 GHz), as indicated in Figure 6(a). Furthermore, it was found that isolation performance greater than 30 dB was obtained with four discrete PIN diodes in the transmitter and receiver arm. By having isolation higher than 30 dB, the proposed design can isolate more than 1 Watt of power leakage in the RF front-end system.

From Figure 6(b), it can be seen that the simulated return loss (S11) was higher than 10 dB at 2.45 GHz. The absorptive feature of the filter-integrated SPDT switch can be seen at Port 2 during transmission mode operation. The simulated return loss (S22) was higher than 16 dB at 2.45

GHz, as indicated in Figure 6(c). Figure 6(d) shows that the simulated result of the insertion loss S13 was 6 dB. Actually, the result of the insertion loss was not the desired result as it was very high. However, this problem could be solved in future work.

Table 1

Summarization of the process in receiver and transmitter modes of absorptive filter integrated SPDT switch using coupled line L-resonator for 2.45 GHz applications

	Receiver Mode	Transmitter Mode
<i>Vbias1 &amp; 2</i>	+5 Volt	-5 Volt
<i>Vbias3 &amp; 4</i>	-5 Volt	+5 Volt
<i>Series PIN diode (D4)</i>	OFF state	ON state
<i>Series PIN diode (D5)</i>	ON state	OFF state
<i>Transmission Line Stub Resonator (S2)</i>	Bandstop response	Allpass response
<i>Transmission Line Stub Resonator (S3)</i>	Allpass response	Bandstop response
<i>Coupled Line L-Resonator (S1)</i>	Bandstop response	Bandpass response
<i>Coupled Line L-Resonator (S4)</i>	Bandpass response	Bandstop response

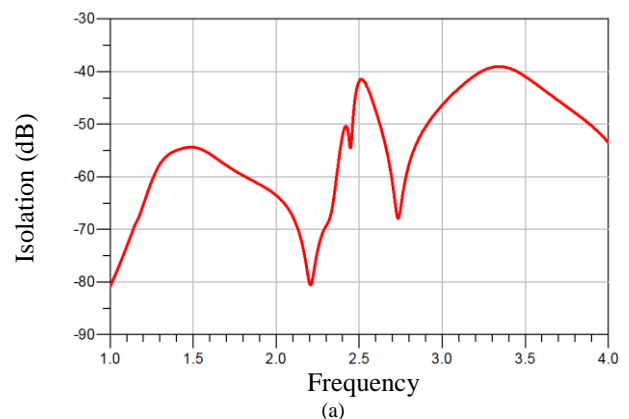

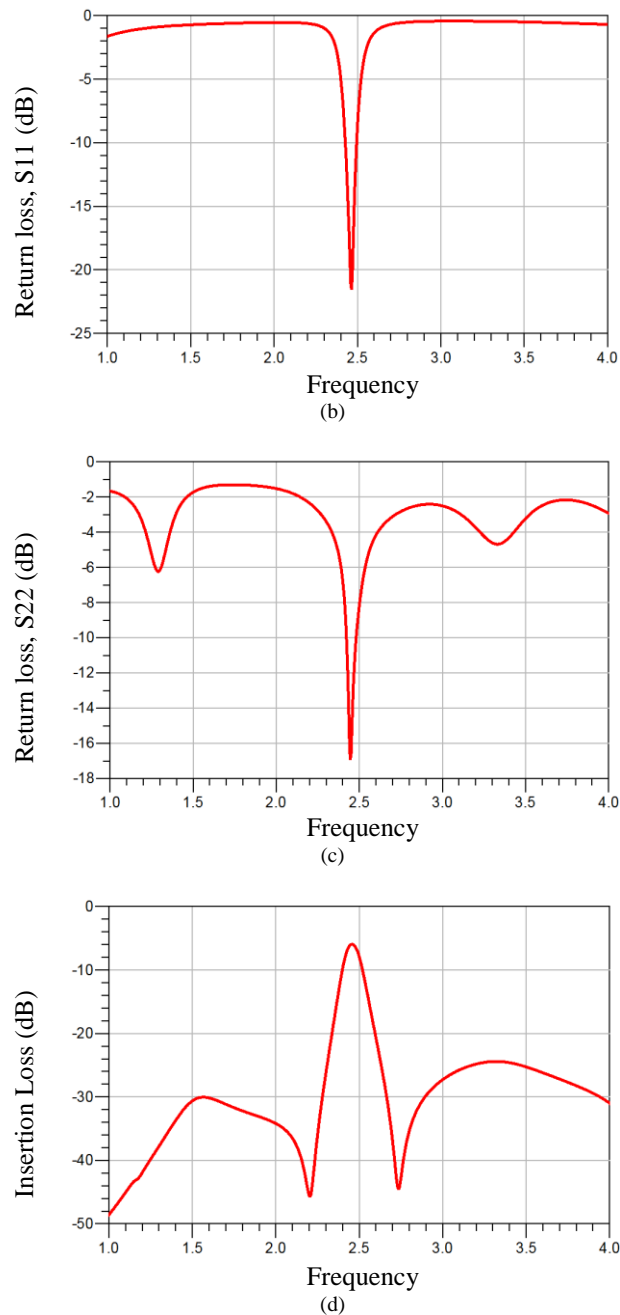

Figure 7: Simulation results of absorptive filter integrated SPDT switch, (a) isolation ( $S_{12}$ ) (b) return loss ( $S_{11}$ ) (c) return loss ( $S_{22}$ ) (d) insertion loss ( $S_{13}$ )

#### IV. CONCLUSION

The proposed absorptive filter-integrated SPDT switch with switchable coupled line L-resonators was designed to analyse 2.45 GHz applications. The theory of matched band-stop filter has been discussed, and it was applied in filter-integrated SPDT switch design. The switchable coupled line L-resonators could be reconfigured between band-stop and bandpass filter responses. The proposed design was successfully simulated in the Advanced Design System (ADS) software. As a result, the design showed more than 30 dB isolations, greater than 10 dB return loss at the used and unused ports. The proposed design has an absorptive feature, which is an effective feature for applications that require good VSWR for all operating ports. Thus, the switchable matched bandstop to bandpass filter has the potential to be used in filter-integrated SPDT switch design.

#### ACKNOWLEDGEMENT

Authors would like to greatly express their thanks and appreciation to UTeM Zamalah Scheme for their help, encouragement and financially supporting to complete this research work.

#### REFERENCES

- [1] R. Singh *et al.*, "A 3 / 5 GHz Reconfigurable CMOS Low-Noise Amplifier Integrated with a Four-Terminal Phase-Change RF Switch," in *2015 IEEE International Electron Devices Meeting (IEDM)*, 2015.
- [2] A. K. Sahoo, R. D. Gupta, and M. S. Parihar, "A  $2 \times 2$  Integrated Filter Antenna Array," in *2017 11th European Conference on Antennas and Propagation (EUCAP)*, 2017, pp. 2205–2208.
- [3] J. Ham *et al.*, "CMOS Power Amplifier Integrated Circuit With Dual-Mode Supply Modulator for Mobile Terminals," *IEEE Trans. Circuits Syst. I Regul. Pap.*, vol. 63, no. 1, pp. 157–167, 2016.
- [4] C. Rave, F. O. Storzjohann, and A. F. Jacob, "A Compact Bandpass Filter Integrated SPDT PIN Switch at X-Band," in *2014 German Microwave Conference (GeMIC)*, 2014.
- [5] J. Lee *et al.*, "Low Insertion-Loss Single-Pole-Double-Throw Reduced-Size Quarter-Wavelength HEMT Bandpass Filter Integrated Switches," *IEEE Trans. Microw. Theory Tech.*, vol. 56, no. 12, pp. 3028–3038, 2008.
- [6] C. Chen, J. Wu, and Y. Lin, "Compact Single-Pole-Double-Throw Switchable Bandpass Filter Based on Multicoupled Line," *IEEE Microw. Wirel. Components Lett.*, vol. 24, no. 2, pp. 87–89, 2014.
- [7] S. Chao, C. Wu, Z. Tsai, H. Wang, and C. H. Chen, "Electronically Switchable Bandpass Filters Using Loaded Stepped-Impedance Resonators," *IEEE Trans. Microw. Theory Tech.*, vol. 54, no. 12, pp. 4193–4201, 2006.
- [8] S. Chao, C. Kuo, Z. Tsai, and H. Wang, "A 40-GHz MMIC SPDT Bandpass Filter Integrated Switch," in *2007 IEEE/MTT-S International Microwave Symposium*, 2007, pp. 483–486.
- [9] Z. M. Tsai, Y. sian Jiang, J. Lee, K. you Lin, and H. Wang, "Analysis and Design of Bandpass Filter-Integrated Switches," *IEEE Trans. Microw. Theory Tech.*, vol. 55, no. 8, pp. 1601–1610, 2007.
- [10] J. Lee, R. Lai, K. Lin, C. Chiong, and H. Wang, "A Q-band Low Loss Reduced-size Filter-Integrated SPDT Switch Using O.15-Jlffi MHEMT Technology," in *2008 IEEE MTT-S International Microwave Symposium Digest*, 2008, pp. 551–554.
- [11] P. Phudpong, N. Youngthanisara, M. Kitjaroen, P. Rattanawan, and S. Siwamogsatham, "A High-Isolation Low-Insertion-Loss Filter-Integrated PIN Diode Antenna Switch," in *2009 Asia Pacific Microwave Conference*, 2009, pp. 1585–1588.
- [12] S. Chao, "42 GHz MMIC SPDT bandpass filter-integrated switch using HEMT loaded coupled lines," *Electron. Lett.*, vol. 48, no. 9, pp. 505–506, 2012.
- [13] R. Phudpong, N. Youngthanisara, P. Kukieattikool, M. Kitjaroen, and S. Siwamogsatham, "An Absorptive Bandpass-Integrated P-I-N Diode T/R Switch for 2.5 GHz WiMAX high power terminals," *Microw. Opt. Technol. Lett.*, vol. 54, no. 12, pp. 2705–2708, 2012.
- [14] J. Xu, Q. Cai, Z. Chen, and Y. Du, "Quasi-Lumped-Element Filter-Integrated Single-Pole Double-Throw Switch," *IEEE Trans. Microw. Theory Tech.*, vol. PP, no. 99, pp. 1–8, 2017.
- [15] S. Chao, C. Kuo, Z. Tsai, K.-Y. Lin, and H. Wang, "40-GHz MMIC SPDT and Multiple-Port Bandpass Filter-Integrated Switches," *IEEE Trans. Microw. Theory Tech.*, vol. 55, no. 12, pp. 2691–2699, 2007.
- [16] J. Lee, Z. Tsai, and H. Wang, "A Band-Pass Filter-Integrated Switch Using Field-Effect Transistors and Its Power Analysis," in *2006 IEEE MTT-S International Microwave Symposium Digest*, 2006, pp. 768–771.
- [17] D. Lee and C. Nguyen, "K / Ka -Band Single-Pole Single-Throw Switch with Integrated Filtering Function," in *2014 IEEE Antennas and Propagation Society International Symposium*, 2014, pp. 631–632.
- [18] W. Liao, C. Chen, and Y. Lin, "Single-Chip Integration of Electronically Switchable Bandpass Filter for 3.5GHz WiMAX Application," in *2010 IEEE MTT-S International Microwave Symposium*, 2010, pp. 1368–1371.
- [19] S. F. Chao and M. W. Shih, "Design of Double-Pole-Double-Throw Bandpass Filter-Integrated Switches," in *Progress In Electromagnetics Research Symposium Proceedings*, 2012, pp. 1241–1244.
- [20] Zahari, M.K., Ahmad, B.H., Wen, W.P., Shairi, N.A., Mutalib, M.A. and Hassan, N. "An Investigation of Switchable Matched Bandstop to

- Bandpass Filter Based on Lossy Resonator." *Journal of Telecommunication, Electronic and Computer Engineering (JTEC)*, 9(1-5), pp.119-123, 2017.
- [21] N. A. Shairi, B. H. Ahmad, P. W. Wong, and Z. Zakaria, "An Overview of Matched Bandstop Filters using Lossy Resonators," *Aust. J. Basic Appl. Sci.*, vol. 8, no. 9, pp. 135–144, 2014.
- [22] M. K. Zahari, B. H. Ahmad, N. A. Shairi, and P. W. Wong, "Reconfigurable Matched Bandstop Filter," in *2011 IEEE International RF and Microwave Conference (RFM 2011)*, 2011, pp. 230–233.
- [23] N. A. Shairi, B. H. Ahmad, M. K. Zahari, P. W. Wong. "The Potential Application of Switchable Matched Parallel-Coupled Stub Resonator in SPDT Discrete Switch Design," *2012 IEEE Asia-Pacific Conference on Applied Electromagnetics (APACE 2012)*, pp. 372-376, 2012.
- [24] N. A. Shairi, B. H. Ahmad, P. W. Wong. "Absorptive SPDT Switch Design using Cascaded Switchable Parallel-Coupled Stub Resonator and Switchable Radial Stub Resonator," *2014 IEEE Region 10 Symposium (TENSYP 2014)*, pp. 310-314, 2014.
- [25] A. C. Guyette, I. C. Hunter, R. D. Pollard, and D. R. Jachowski, "Perfectly-Matched Bandstop Filters using Lossy Resonators," in *2005 IEEE MTT-S International Microwave Symposium Digest*, 2005, pp. 517–520.
- [26] D. R. Jachowski, "Passive Enhancement of Resonator Q in Microwave Notch Filters," in *2004 IEEE MTT-S International Microwave Symposium Digest*, 2004, pp. 1315–1318.