

Development of Portable Air Conditioning Using Peltier Effect for Small Area Uses

A. Shamsul Rahimi A. Subki, Wan Norhisyam Abd Rashid, Ir. Nik Azran Ab Hadi, Aiman Zakwan Jidin and Tan Sze Ying

Department of Electronic and Computer Engineering Technology, Faculty of Engineering Technology, Universiti Teknikal Malaysia Melaka, Durian Tunggal 75450, Malaysia
shamsulrahimi@utem.edu.my

Abstract— Air conditioning is the science of controlling dependent parameters such as human comfort, temperature, relative humidity and air quality. This paper presented the development of a portable air conditioning using Peltier Effect in the small area uses using Boost converter as current control devices. A Boost converter has been designed in order to supply a sufficient current that required to the Peltier module to operate. An Arduino UNO board is used to supply the boost converter with pulse width modulation to ensure the boost converter is able to boost the current up until required range of operation. The circuit then simulated using Proteus PCB Design and Simulation to validate the output voltage and current. Based on our findings, the boost converter is operated as predicted in term of a step up the current and voltage. The temperature for cold side are observed reach 23.6 °C in 300s at less than 1A current. This is due to Peltier module is a current control device where when the current increases, the efficiency decreases while maximum cooling occurs at some specific current. If we increased the output current, the cold side is observed to reach 23.6 °C in less than 240s. Based on our findings, this portable air conditioning is useful to cool a small area (20inch x 20inch) with ambient temperature during full load is consistently recorded at 23.6°C.

Index Terms—Boost Converter; Peltier Effect; Seeback Effect; Thermoelectric Cooler.

I. INTRODUCTION

A portable air conditioner is developed using the Peltier effect. The Peltier module, also known as the thermoelectric module is an energy converter in solid state that consists of a cluster of the thermocouple that connects in series and thermally in parallel in an electrical circuit. A Peltier module is also able to transfer heat from one region to the other region using the Peltier effect. It functions when two heat sinks are pasted to its hot and cold parts for the heat transfer. The power sources for the portable air conditioner is the DC portable batteries which had connected to a boost converter which act as a medium to boost up a lower voltage to a desired higher voltage which fulfills the requirement of the portable air conditioner.

The Pulse Width Modulation (PWM) which can be programmed by using an Arduino Uno R3 is also needed to connect to the components that act as a switch where PWM is a manner to send a signal which is in varies from a given set signal. PWM can change the duty cycle of a square wave to vary the power supplied. For the prototype of the air conditioner, it uses the mechanism of the air flow where the neutral air flows into the prototype and the hot air and cold air are dissipated. The prototype of air conditioner that used

the Peltier TEC module using the Peltier effect causes the heat to liberate or absorb when an electric current flow across an intersection point of two different metals. When the current that flows through the Peltier module increases within the specific values, the lower the temperature it is.

II. THEORY AND RELATED OVERVIEW

A. Thermoelectric Cooler (TEC)

Thermoelectric Cooler (TEC) is a semiconductor based electronic part integrates a number of thermoelectric components, which are joined thermally in parallel and electrically in series. The thermoelectric elements are made out of a pair of p-type and n-type semiconductors. When electric current flows across the thermoelectric components, the heat is transported from the cold side to the hot side caused by the Peltier effect [1].

A schematic diagram of TEC module is shown in Figure 1 [2]. A thermoelectric cooling system usually contains a grid arranged semiconductor pellets crammed in between two large electrodes. When a DC power is supplied in between the electrodes, the negatively charged side becomes cooler while the positively charged side becomes warmer. The negative electrode is set in contact with the medium to be cooled, while the positive electrode is coupled to a heat sink that dissipates thermal energy into the external environment.

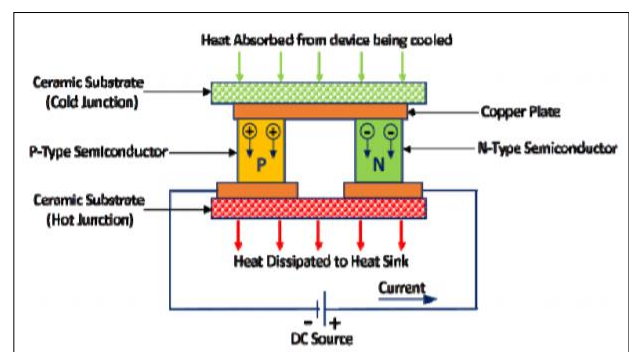

Figure 1: Schematic diagram of the Thermoelectric Cooler (TEC)

At large, thermoelectric cooler operates at higher current compare to other conventional system. However, in situations with small area usage, the thermoelectric cooling strategy is practical and more financial reliable compare to the conventional cooling system.

TEC modules obvious features of being lightweight, absence of moving mechanical parts, compactness, noiseless in operation, transferability, highly reliable, long working life

and less maintenance requirements [3-6]. Thermoelectric Coolers (TECs), converting a direct current into a temperature gradient [7]. The cooling effect of TEC module is increasing by increasing the electrical current which in turn leads to minimize the cell temperature and higher output power.

B. Boost Converter

The boost converter is also known from a family of non-isolated for power topology stage, in most cases, being called a step-up voltage current stage. The power supply configuration selects the boost power stage in order to require the greater output than the input voltage. The input current for a boost power stage is perpetual, or non-pulsating because the output diode is conducted only during a part of the switching cycle. The output capacitor supplies the complete load current for the rest of the switching cycle. Figure 2 illustrates a simplified schematic of the boost converter power stage.

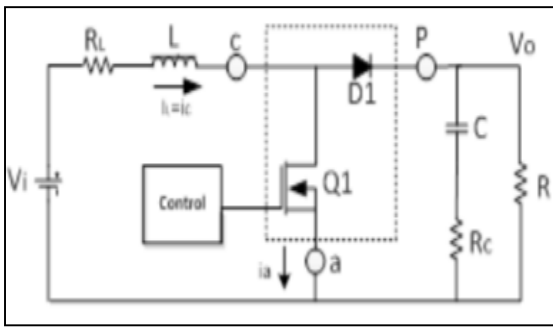

Figure 2: DC Boost converter schematic [8].

Inductor and capacitor are not at all like buck converter, where peak-to-peak output voltage ripple is dependent on L . The inductor DC resistance, R_L , is incorporated into the investigation and capacitor equivalent series resistance (ESR). Meanwhile, R_C represents R resistor of the load seen by the output power supply. A power stage operating can be in the discontinuous or continuous inductor current mode. In the continuous mode, the current flows constantly in the L during the entire switching cycle in steady-state operation. On the other hand, in the discontinuous mode the L is zero for a part of the switching cycle. It obtains peak value at zero, and returns to zero during each switching cycle.

For a power stage, it is attractive to stay in one mode over its expected operating conditions because the power stage frequency response changes significantly between the two operating modes. In the (CCM), the power is transferred from source to load utilizing a two stage process. When Q_1 is turned on, the inductor stores the energy power which equivalent circuit appears in Figure 3.

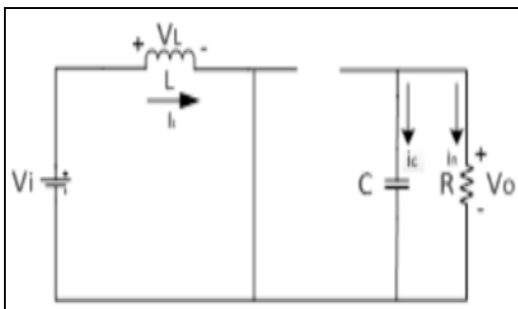

Figure 3: Equivalent circuit during ON state condition.

When Q_1 is left opened, the energy power is stored in the

inductor and the provided energy power is transferred to the load via the diode as shown in Figure 4 [9].

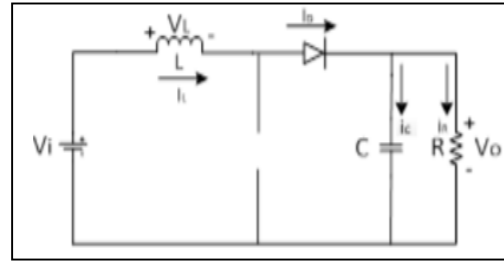

Figure 4: Equivalent circuit during OFF state condition.

III. PROPOSED DESIGN

First, the entire process of simulating and fabrication is planned and can be summarized as shown in the flowchart in Figure 5. Using schematic circuits as shown in Figure 6, the prototype of the portable air conditioner was first assembled in order to determine the voltage and current required by the portable air conditioner. After the measurement, the voltage needed by the Peltier module was about 12V and the current needed to be about 4.5A.

For boost converter design, the procedure as shown in Figure 7 is carefully followed in order to achieve the well working boost converter with sufficient output current. A basic boost converter was first designed using the topology of the boost converter but the circuit was not functioning as expected because the value of the components that had bought in marketing was not matched as the calculated value. This is because there were no components that had the exact value. Besides, every component also had its own tolerance that cannot be measured during calculation because the components will affect the result of the boost converter practically. Thus, the basic boost converter was not suited in this case because of the non-ideal of the components.

IV. RESULT AND DISCUSSION

A boost converter using ATtiny85 was used where the microcontroller, ATtiny85 acts as a switch control in this circuit. The ATtiny85 has a faster response time compared to the BJT and power MOSFET. Since the ATtiny85 is an IC that can only function within 5V, thus a voltage regulator was connected to the input power in order to regulate to 5V. This circuit had successfully boosted the voltage from 5V to 13.2V but the current was remained small. Figure 8 showed the hardware circuit connection.

In order to amplify the current from the boost converter using ATtiny85, a current gain circuit was designed using the TIP 2955 which was designed for the general purpose of switching and amplifier applications. It was used to provide the most current to the load and to maintain a constant voltage by the little current still through the regulator IC intact. Figure 9 showed the current gain circuit.

Thus, another current gain circuit using Darlington Pair was designed to amplify the current which expected to amplifier the current up to 4A. In the circuit, the TIP41A was used because it can allow 4A of the current to flow through it but because there was a large current to flow across it, thus a heat sink was needed to paste with the transistor in order to prevent the transistor to be burnt. Unfortunately, this circuit did not success again due to the input current which was too small to be amplifier using this circuit. Table 1 shows the

summary of the values of voltage and current of the boost converter and the variation has been plotted as in Figure 10.

A boost converter module and portable batteries were used in order to obtain the temperature changes of the Peltier module when a current passes across it. The boost converter module that had been used was a non-isolated step-up switching regulator. Since the current needed by the Peltier module was about more than 3A to produce a cooler temperature at the cold side, thus a 6V 4.5Ah portable rechargeable battery was used in order to provide a higher current per hour for the circuit to be functioning. Besides, the output voltage and output current of the boost converter module was not enough for the fans and the Peltier module to be functioning, thus another 12V 1.2Ah portable rechargeable power supply was used as the power supply for the fans and the 6V 4.5Ah portable power supply was only connected to the Peltier module.

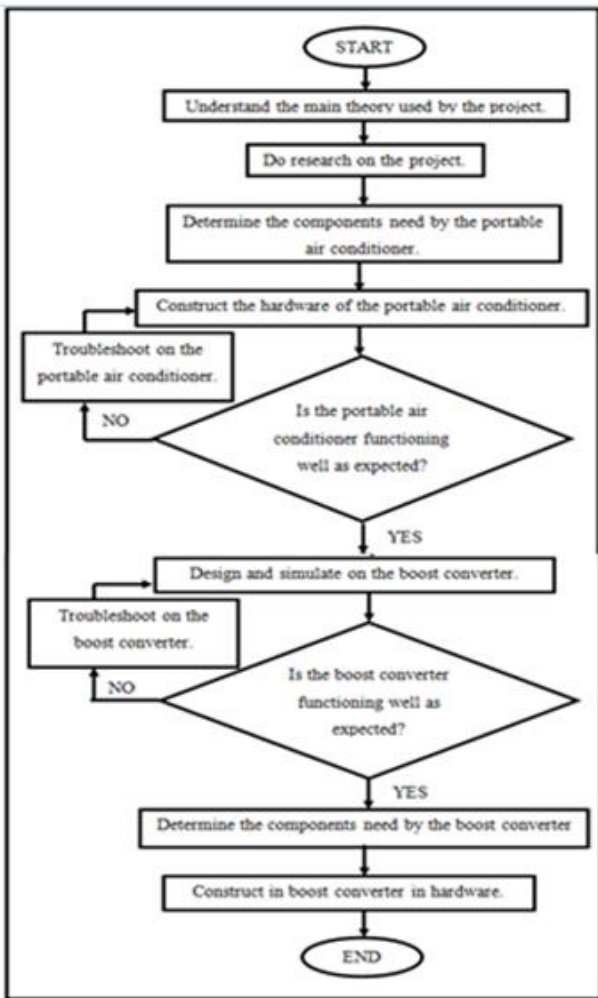

Figure 5: Overall process flowchart

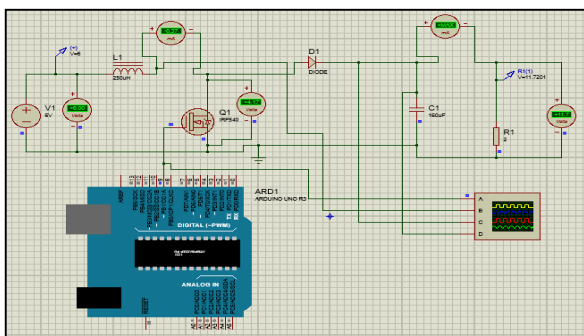

Figure 6: Schematic of the Arduino Uno R3 Produces PWM pulse

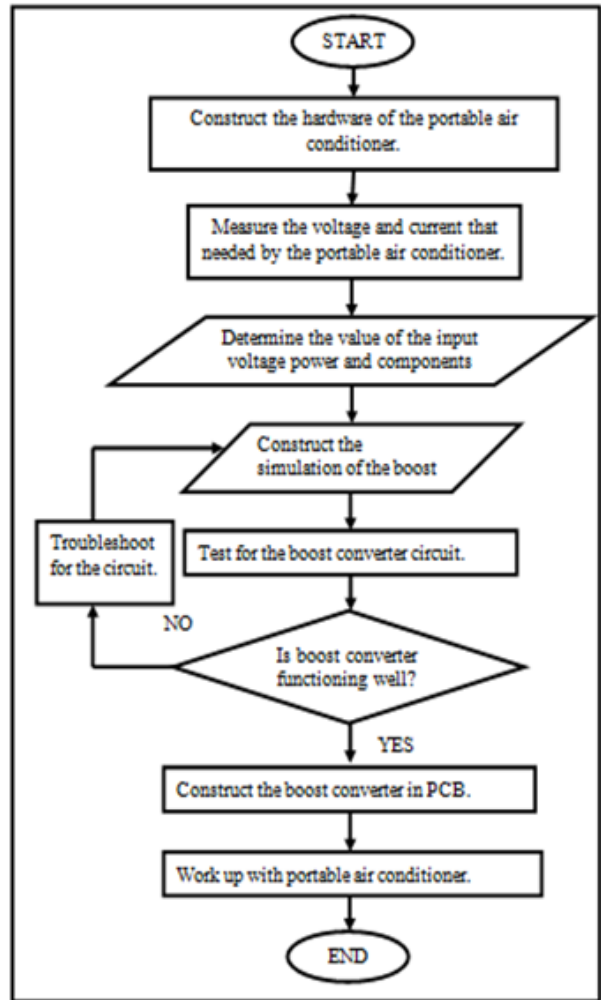

Figure 7: Boost converter design flowchart



Figure 8: The Hardware Circuit of the Voltage Regulator and Boost Converter Using ATtiny85.



Figure 9: Current Gain Circuit

Table 1
Data of the hot temperature against time

Time(s)	Temp1 (°C)	Temp2 (°C)	Temp 3 (°C)	Average Temp (°C)
0	31.5	31.1	31.3	31.30
30	32.9	31.9	33.4	32.73
60	33.6	32.5	33.8	33.30
90	34.0	33.1	34.2	33.77
120	34.4	33.4	34.2	34.00
150	34.5	33.5	34.2	34.07
180	34.6	33.4	34.1	34.03
210	34.6	33.9	34.5	34.33
240	34.3	34.2	34.6	34.37
270	34.6	34.0	34.8	34.47
300	34.5	33.7	34.7	34.30

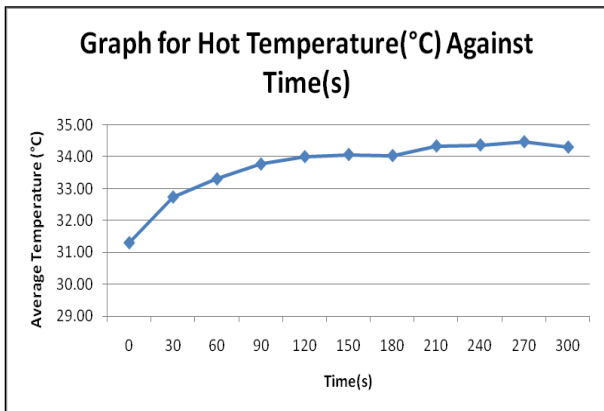

Figure 10: Graph of Hot Temperature (°C) Against Time (s)

Table 2
Data of the hot temperature against time

Time(s)	Temp1 (°C)	Temp2 (°C)	Temp 3 (°C)	Average Temp (°C)
0	31.4	31.2	31.2	31.27
30	37.1	28.3	28.3	31.23
60	26.9	25.7	25.9	26.17
90	25.0	24.4	25.5	24.97
120	24.3	24.1	24.4	24.27
150	23.6	23.7	23.8	23.70
180	23.7	23.6	23.8	23.70
210	23.6	23.3	23.4	23.43
240	23.6	23.6	23.2	23.47
270	24.0	24.0	23.8	23.93
300	23.5	24.0	23.3	23.60

The hardware of the prototype of portable air conditioner had been done, the temperature of the air flow out from the portable air conditioner was measured using the IR Thermometer UT300A. The data of hot and cold temperature were recorded as shown in Table 2 and while the graph that showed the relationship between the temperature against time were as shown in Figure 11.

From the data obtained, it showed that the hot temperature was slightly increased and then almost constant against time. This is because during 0s, it was the surrounding temperature of around 31.3°C. After the portable air conditioner was connected to batteries, the temperature was slight increases at the hotter part due to the movement of the neutral air into the heat sink that pasted with the Peltier Module which had

converted into the hotter air. On the other hand, the cold temperature of the colder part was decreased and the constant when the time was increased. This was also due to the movement of the neutral air at the colder part into the heat sink that pasted with the Peltier Module which had converter into the colder air. The cold temperature of the portable air conditioner had become colder and colder until about 23°C because of the flow of the current to the Peltier Module. At 0s, the initial current was not constant enough for the temperature to drop. When the time increased, the current that flows through the Peltier module also increased and then constant, thus the temperature started to drop against the time. Besides, the temperature of the air conditioner was not cold enough due to the insufficient of the current flow through the Peltier module where Peltier module is a current control device that acts as a temperature control with high efficiency

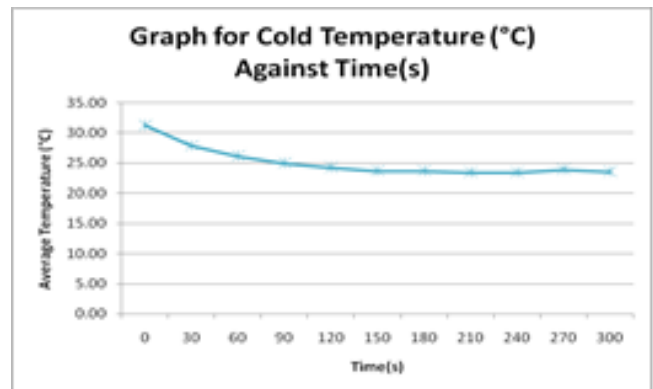

Figure 11: Graph of Cold Temperature (°C) Against Time(s)

V. CONCLUSION

Integration between an Arduino UNO with proposed boost converter design is successfully carried out. Pulse width modulation is fed to boost converter to ensure the boost converter is able to boost the current up until required range of operation. Based on experimental analysis data, the temperature was slight increases at the hotter part due to the movement of the neutral air into the heat sink that pasted with the Peltier Module which had converted into the hotter air. On the other hand, the cold temperature of the colder part was decreased and the constant when the time was increased. The temperature for the cold side is observed reach 23.6 °C in 300s at less than 1A current. When the output current increased the, the cold side is observed to reach 23.6 °C in less than 240s. Based on our findings, this portable air conditioning is useful to cool a small area (20inch x 20inch) with ambient temperature during full load is consistently recorded at 23.6°C

ACKNOWLEDGMENT

The authors wish to thank Universiti Teknikal Malaysia Melaka (UTeM) for Fellowship award and Ministry of Higher Education, Malaysia (MOHE) for supporting this research under the grant (PJP/2015/FTK (2B)/S01398).

REFERENCES

- [1] Sarhaddi F, Farahat S, Ajam H, Behzadmehr A. Exergetic performance assessment of a solar photovoltaic thermal (PV/T) air collector. Energy and Buildings., 42, pp. 2184–2199 (2010)

- [2] Kumar RS, Priyadarshini NP, Natarajan E. Experimental and Numerical Analysis of Photovoltaic Solar Panel using Thermoelectric Cooling. *Indian Journal of Science and Technology*. 8(36), pp 252-256 (2015)
- [3] Elsheikha MH, Shnawah DA, Sabri MFM, Said SBM, Hassan MH, Bashir MBA, Mohamadb M. A review of thermoelectric renewable energy: Principle parameters that affect their performance. *Renewable and Sustainable Energy Reviews*. 30 (2), pp. 337–55. (2014)
- [4] Omer SA, Infield DG. Design and thermal analysis of a two stage solar concentrator for combined heat and thermoelectric power generation. *Energy Conversion and Management*, 41 (7), pp. 737–56.
- [5] Riffat SB, Omer SA, Ma X. A novel thermoelectric refrigeration system employing heat pipes and a phase change material: an experimental investigation. *Renewable Energy*. 23, pp. 313–23 (2001)
- [6] Kane A, Verm V. Performance enhancement of building integrated photovoltaic module using thermoelectric cooling. *International Journal of Renewable Energy Research*. 3, pp. 320–324 (2013)
- [7] Ahiska R, Dislitas S, Omer G. A new method and computer-controlled system for measuring the time constant of real thermoelectric modules. *Energy Conversion and Management*. 53, pp. 314–321 (2012)
- [8] Mohammed Rasheed, Rosli Omar and Marizan Sulaiman. Design and Development of DC-DC Boost Converter based on DSP TMS320F2812 for PV Application. *Indian Journal of Science and Technology*. 9(44) (2016)
- [9] Pal S., Dalapati S. and Processors D. S., “Digital simulation of two level inverter based on space vector pulse width modulation. *Indian Journal of Science and Technology*. 5(4), pp. 2557–2568 (2012)