

Switchable Function of Reconfigurable Feeding Network and SPDT Switch

N.Edward, Z.Zakaria and N.A.Shairi

Center of Telecommunication Research and Innovation (CeTRI),

Faculty of Electronic and Computer Engineering (FKEKK), Universiti Teknikal Malaysia Melaka (UTeM)

zahriladha@utem.edu.my

Abstract—Switchable function of reconfigurable feeding network and Single Pole Double Throw (SPDT) switch related to WiMAX application is proposed in this paper. Positive Intrinsic Negative (PIN) diode is used to realize switchable function and the operating frequency for power divider and SPDT switch. At the output ports, PIN diodes are added for SPDT switch function by turning on and off the output port. Then, the stub is added at the output port for matching when the function of the power divider is changed to SPDT switch. Rogers RO4350 ($\epsilon_r = 3.48$, $h = 0.508\text{mm}$) is used as a substrate material and the copper (thickness = 0.035 mm) related to patch of this proposed design. The simulation results for power divider at both frequencies are S_{11} less than -25 dB . The insertion loss, S_{12} and S_{13} , for power divider at 2.5 GHz and 3.5 GHz are -3.733 dB and -3.634 dB respectively. Meanwhile, the simulation results for SPDT switch showed that the S_{11} is less than -15 dB ; S_{12} and S_{13} are better than -2 dB and infinity isolation for S_{23} and S_{13} for both WiMAX frequencies. Based on the simulation results, power divider and SPDT switch were well applied where it has better return loss with less than -25 dB and -15 dB respectively. The proposed design realized a switchable function which can perform as either reconfigurable power divider or SPDT switch by using PIN diodes and it can be used for power amplifiers or antenna array applications.

Index Terms— Reconfigurable Feeding Network; SPDT Switch; Switchable Function; WiMAX Standards.

I. INTRODUCTION

Recently, reconfigurable mobile terminals have become the trend. Hence, there are many reconfigurable antennas have been validated in practice and examined [1]-[3]. The importance of advanced feeding network is to support the systems such as phase-array antennas and smart antennas to be fully achieved [4]-[6]. The Wilkinson power divider (WPD) is one of the fundamental parts in a different type of microwave circuits and it has been normally utilized for power division and combination in antenna's feeding network [6]-[8]. The conventional Wilkinson divider utilizes two quarter-wavelength transmission lines and only operates at a certain frequency [9].

In order to realize the tunable function of the power divider, there are several methods can be done, such as using varactors [10]-[13]. But by using varactors, the design of WPD would become more complex. In [12], the tunable power divider is designed by electrifying the upper and lower surface electrode of the liquid crystal (LC) and changing the voltage value [14]. However, this design would complicate the fabrication process. Furthermore, PIN diodes can be used to obtain the tunable power divider capabilities [15], [16]. Besides, from the power divider design, the SPDT switch function also can be achieved by using PIN diodes. PIN

diodes are an essential component in designing SPDT switch. In [17], the function of the power divider can be switchable which it can become a power divider or SPDT switch by using PIN diodes in a single design. However, the proposed design's size is large and difficult to fabricate.

This project presents a miniaturized switchable function of reconfigurable feeding network and SPDT switch for WiMAX standards, which are 2.5 GHz and 3.5 GHz . The feeding network comprises of two modified WPD which can be individually reconfigured in length by using PIN diodes switches. By adjusting the bias voltages of these PIN diodes, the operating frequency of the proposed design can be altered between two different frequency bands. The proposed design also can switch its function from power divider into SPDT switch compared with [15]. Furthermore, the proposed design has a new feature which is multiband for both functions compared to [17]. However, there is a mismatch when the function is switched into SPDT switch. Therefore, two shorted stubs are introduced at the output ports for matching the 2.5 GHz and 3.5 GHz SPDT switch. In this paper, the switchable function of reconfigurable feeding network and SPDT switch is designed, simulated and investigated.

II. RESEARCH METHODOLOGY

A. Wilkinson Power Divider and Design Equation

The Wilkinson power divider, proposed by Ernest Wilkinson in 1960 gives isolation between ports in the output, is adept in matching in all ports, and can be lossless when port at the output matches [18]. Figure 1 presents the equal transmission line circuit for WPD, where the force delivered to both ports at the output is equivalent [9].

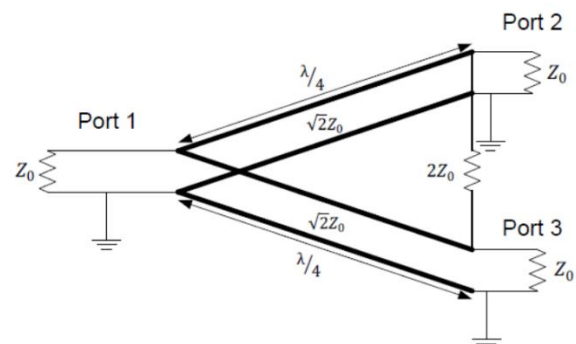

Figure 1: The circuit model of the transmission line for WPD [9]

Wilkinson Power Divider is a three port network consisting of one input port and two output ports as shown in Figure 1. Mostly, depend on the application using it, power is divided equally or unequally at two different working of frequencies.

The WPDs at operating frequency of 2.5 GHz and 3.5 GHz used $Z_0 = 50 \Omega$ to design the power divider in which it needs a resistor of isolation to be $2Z_0 = 100 \Omega$ and the impedance of quarter-wave section split transmission line become $\sqrt{2}Z_0 = 70.7\Omega$. The perfect S-matrix of the Wilkinson power divider with a load that is matched is shown in (1).

$$S = \frac{-j}{\sqrt{2}} \begin{pmatrix} 0 & 1 & 1 \\ 1 & 0 & 0 \\ 1 & 0 & 0 \end{pmatrix} \quad (1)$$

Scattering matrix indicates that as the signal entered to the port two, it will be the same which separated into ports two and three. Port which is matched sets S_{11} , S_{22} and S_{33} equals zero. As the signal is entered the port one, the power divider would be lossless. The magnitude (total squares each component) of column one of the scattering matrix is equivalent to one [9].

B. The Proposed Design of Modified WPD and SPDT Switch

Figure 2 shows the proposed design of the switchable function of reconfigurable feeding network and SPDT switch; and the position of the PIN diodes (D1-D14). A parametric study is done to make the design narrowband. Narrowband is required in this proposed design so that only signals at 2.5 GHz or 3.5 GHz is allowed. Since in this proposed design it required to be operated either at 2.5 GHz or 3.5 GHz, there are two modified WPDs are designed at different frequencies. After that, both designs are combined to make it into one design by using PIN diode. PIN diodes are used in this design to reconfigure the length of the transmission line in power divider. For SPDT switch function, one of the output port will be turned off. In this proposed design, PIN diodes play an important role to make the design have dual functions either reconfigurable feeding network or SPDT switch.

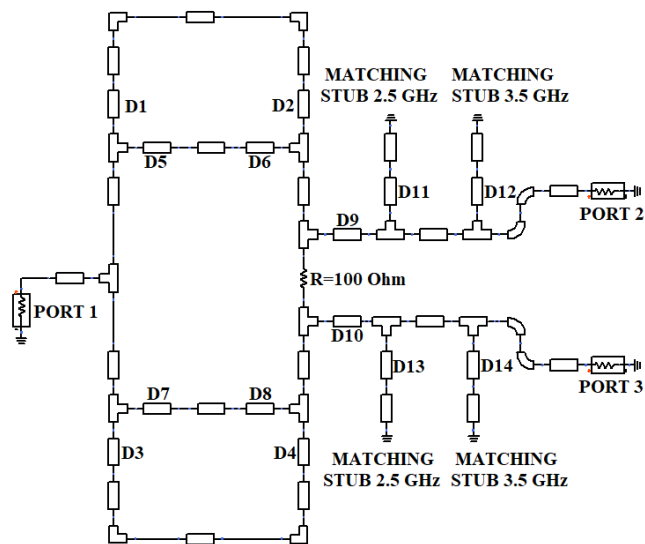

Figure 2: The proposed design of the switchable function of reconfigurable feeding network and SPDT switch

From Figure 2, when D5, D6, D7, D8, D11, D12, D13 and D14 are turned off, the power divider operates at frequency of 2.5 GHz and when D1, D2, D3, D4, D11, D12, D13 and D14 are turned off, the power divider operates at frequency of 3.5 GHz. Figure 3 (a) and (b) shows the circuit configuration when the power divider is at operating frequency of 2.5 GHz and 3.5 GHz respectively.

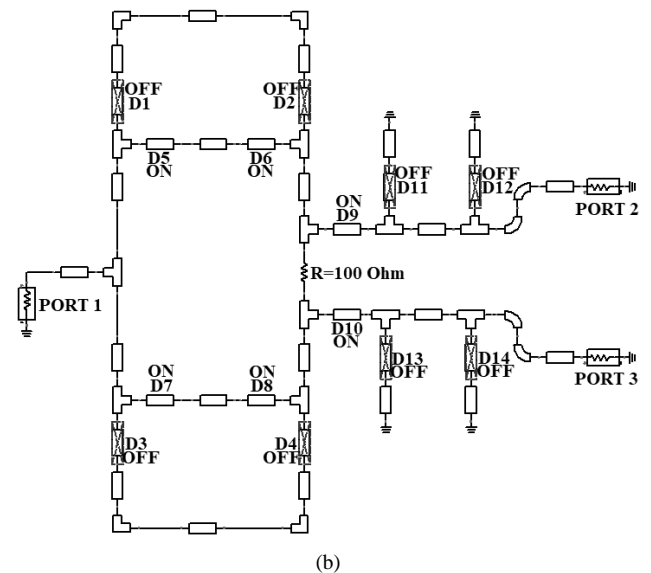
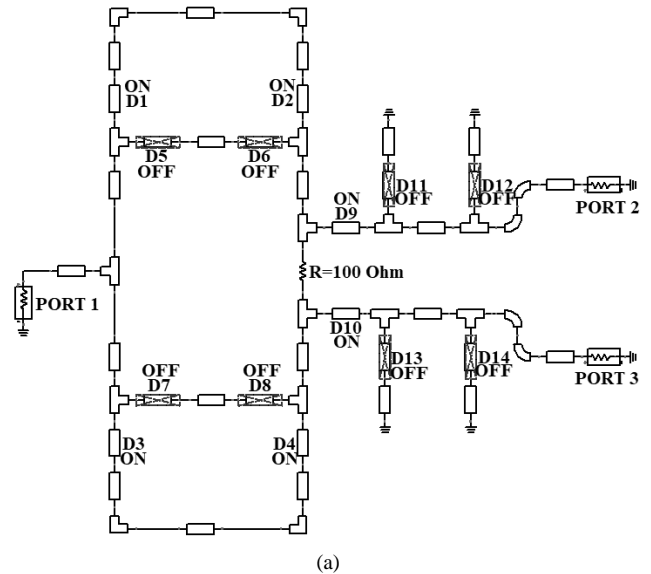

Figure 3: (a) Circuit configuration of power divider at 2.5 GHz and (b) circuit configuration of power divider at 3.5 GHz

From Figure 2, in order to turn off one of the connected output ports, PIN diodes D9 or D10 will be turned off to achieve an SPDT switch function. However, there will be a mismatch when one of the output port is turned off. This can be overcome by placing stub at the output ports. Two stubs are placed at the output port for matching SPDT switch at 2.5 GHz and 3.5 GHz. The SPDT switch function is also reconfigurable in terms of its operating frequency. It can operate either at 2.5 GHz or 3.5 GHz. Figure 4 (a) and (b) shows the circuit configuration for SPDT switch at 2.5 GHz and 3.5 GHz respectively.

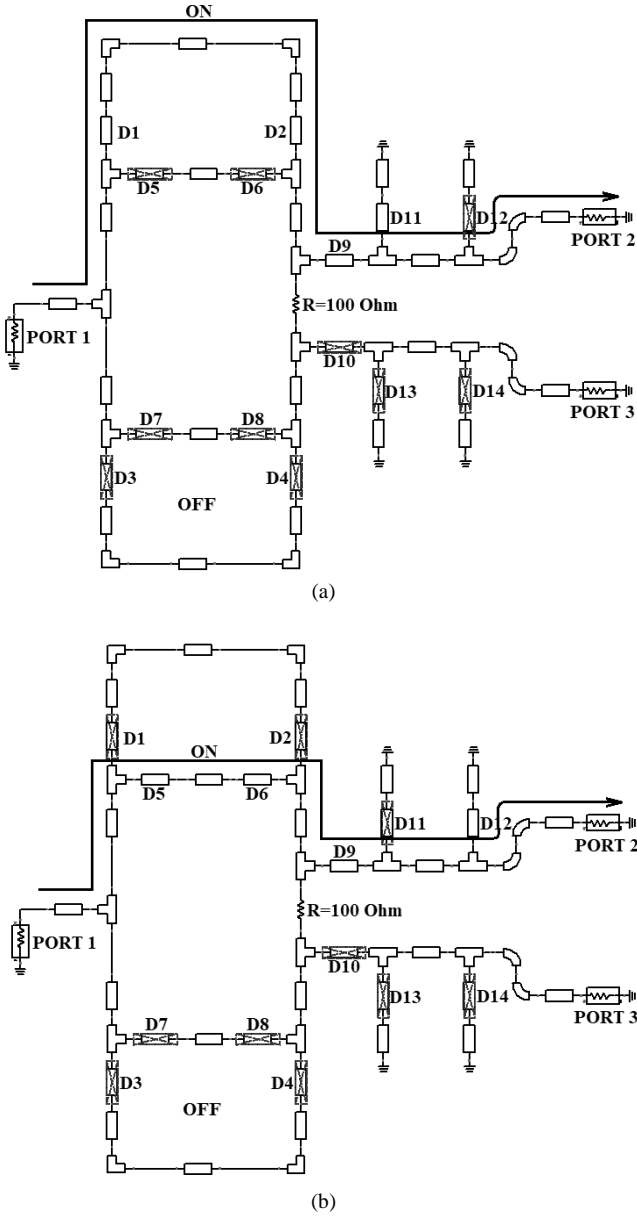

Figure 4: (a) The circuit configuration for SPDT switch at 2.5 GHz and (b) the circuit configuration for SPDT switch at 3.5 GHz

III. RESULTS AND ANALYSIS

A. The Proposed Design of Reconfigurable Modified WPD

It has been analyzed that the transmission line at port 1 effect the most to make it narrow band. That's mean this power divider does not have the same impedance with the conventional Wilkinson power divider. That is because the transmission line at the ports of the conventional Wilkinson power divider is Z_0 which is 50Ω , but after tuning the width and length of the transmission line, it will not have the same impedance. Therefore, for the conventional power divider, all transmission lines will be in the same width and length of the transmission line. But, for this design to have a narrow frequency band, the transmission line at the ports does not have the same size, which means that, port 1 have different values of impedance than port 2 and 3. After tuning the transmission line at the ports, port 1 has a different dimension than port 2 and 3. But, for port 2 and port 3, it has the equal dimension of transmission line even after tuning. That is

because it is to achieve the same output at port 2 and port 3. After that, both modified WPD's designs are combined to make it into one design by using PIN diodes to reconfigure the length of the power divider. From the analysis that has been made, it is found that the transmission line of the ports plays an important role in getting a narrow band.

The proposed power divider in Figure 3 is simulated to obtain the S_{11} , S_{12} , S_{13} , S_{21} , S_{31} and S_{23} at 2.5 GHz and 3.5 GHz. The following Figure 5 and 6 shows the result for S_{11} , S_{12} , S_{13} , S_{21} , S_{31} and S_{23} at 2.5 GHz and 3.5 GHz respectively. The PIN diode D1-D8 in the design is assumed as a switch on and off to switch the frequency either 2.5 GHz or 3.5 GHz. For the power divider function, the PIN diode D11-D14 is turned off.

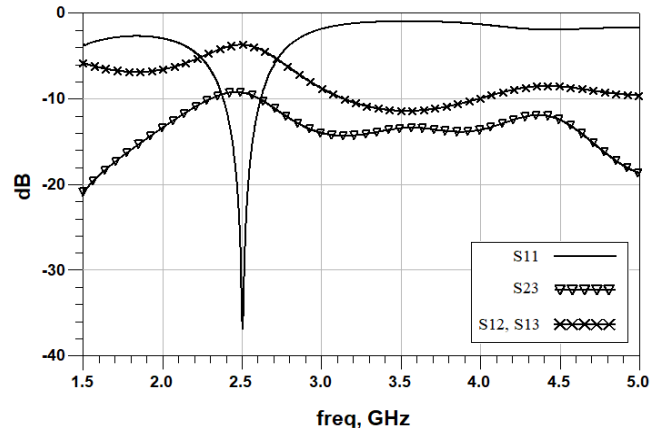

Figure 5: S_{11} , S_{12} , S_{13} , S_{21} , S_{31} and S_{23} results for modified WPD at 2.5 GHz.

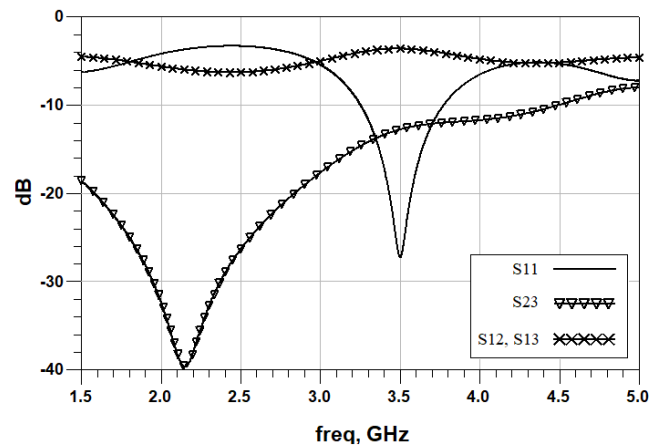

Figure 6: S_{11} , S_{12} , S_{13} , S_{21} , S_{31} and S_{23} results for modified WPD at 3.5 GHz.

The return loss of proposed WPD at 2.5 GHz is about -34.732 dB, S_{23} is -9.310 dB, S_{12} and S_{13} is -3.733 dB. Meanwhile, the return loss of WPD at 3.5 GHz is about -27.252 dB, S_{23} is -12.779 dB, S_{12} and S_{13} is -3.634 dB.

B. Design of Reconfigurable SPDT Switch

The PIN diodes D9 and D10 play an important role to switch the function of reconfigurable power divider into SPDT switch. When one of the PIN diodes D9 or D10 is turned off, the proposed design will function as SPDT switch. It can switch either using port 2 or 3. In addition, this SPDT

switch functions also reconfigurable in terms of its operating frequency. It can operate at frequencies of 2.5 GHz or 3.5 GHz. However, when one of the port is turned off, there will be a mismatch. Therefore, in this proposed design, two stubs are added to overcome this problem. One stub for matching the SPDT switch at 2.5 GHz and another one for SPDT switch at 3.5 GHz. These stubs will turn on when it is needed. The PIN diode D11-D14 will turn on or off the stubs based on the condition needed.

In order to obtain SPDT switch function at 2.5 GHz, one of the port needs to be turned off. For example, when port 2 is needed to be turned on, the PIN diode D9 will turn on and D10 will be turned off. Since port 3 is turned off, all the PIN diode (D3, D4, D7, D8) at the transmission line connected to output port 3 will be turned off. Meanwhile, the PIN diode D1, D2, D5 and D6 will make the SPDT switch reconfigurable in terms of its operating frequency. D1 and D2 will be turned on for SPDT switch function at 2.5 GHz and PIN diodes D5 and D6 for 3.5 GHz. The stub at 2.5 GHz will be turned on by the PIN diode D11 for matching and D12 is for matching SPDT switch function at 3.5 GHz. Figure 7 and 8 shows the return loss, S11 and insertion loss, S12, S13 for both frequencies at 2.5 GHz and 3.5 GHz for SPDT switch, respectively. It can be seen that both frequencies have return loss less than -15 dB, insertion loss less than -2 dB and infinity isolation for S23 and S13.

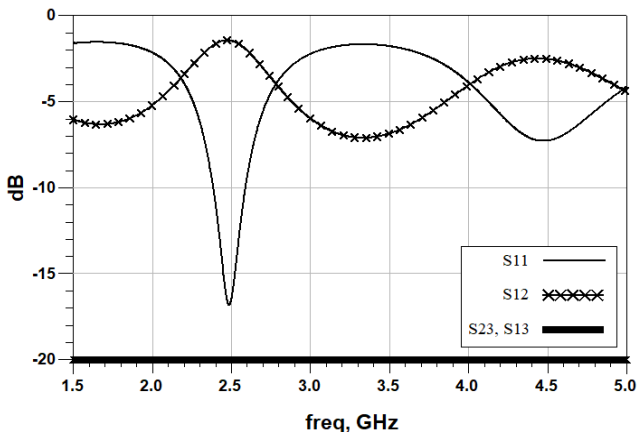

Figure 7: Simulation result, S11, S12, S13, S21, S31 and S23 for SPDT switch at 2.5GHz

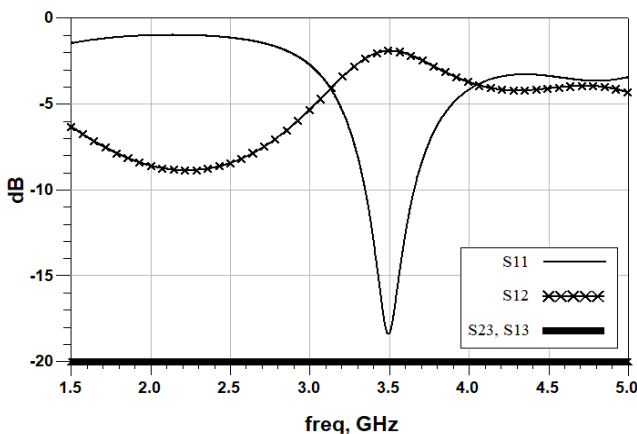

Figure 8: Simulation result, S11, S12, S13, S21, S31 and S23 for SPDT switch at 3.5GHz

Table 1 shows the comparison of this work with previous work on the reconfigurable feeding network. In [17], the design is based on the conventional WPD and used PIN diode as the tuning element. The conventional WPD has a wideband frequency. So, it cannot work with dual-band filter and can only reconfigure the operating frequency of the power divider.

Table 1
Comparison with Previous Work

	[15]	This Work
Type of power divider	Conventional Wilkinson Power Divider	Modified Wilkinson Power Divider
Tunable Element	PIN diode	PIN diode
Type of Frequency Band	Wideband	Narrowband
Tunable Properties	Operating Frequency of Power Divider	Operating Frequency and Switchable Function of SPDT Switch and Power Divider

IV. CONCLUSION

The design of the switchable function of reconfigurable feeding network and SPDT switch for WiMAX applications have been successfully designed, simulated, and investigated. Two of Wilkinson power dividers are designed and combined by reconfiguring the length of the transmission line using PIN diode. The conventional WPD has a wideband frequency, but for this WPD design, it requires narrowband frequency either at a frequency of 2.5 GHz or 3.5 GHz. The simulation results of the switchable feeding network show good agreement for both frequencies with the return loss below -25 dB and S12/S13 better than -3.8 dB that have been achieved. Meanwhile, for SPDT function, the simulation results also show good agreement for both frequencies with return loss less than -15 dB and insertion loss better than -2 dB.

ACKNOWLEDGMENT

We are grateful to UTeM Zamalah Scheme, Center for Research and Innovation Management (CRIM), Universiti Teknikal Malaysia Melaka (UTeM), and MOHE under research grant FRGS/1/2016/TK04/FKEKK-CeTRI/F00311 for their encouragement and help in supporting financially to complete this research work.

REFERENCES

- [1] A. Ghasemi, N. Ghahvehchian, A. Mallahzadeh and S. Sheikholvaezin, "A reconfigurable printed monopole antenna for MIMO application," in *2012 6th European Conference on Antennas and Propagation (EUCAP)*, Prague, pp. 1-4, 2012.
- [2] J. H. Lim, G. T. Back, Y. I. Ko, C. W. Song and T. Y. Yun, "A Reconfigurable PIFA Using a Switchable PIN-Diode and a Fine-Tuning Varactor for USPCS/WCDMA/m-WiMAX/WLAN," *IEEE Transactions on Antennas and Propagation*, vol. 58, no.7, pp. 2404-2411, 2010.
- [3] A. Khaleghi and M. Kamyab, "Reconfigurable Single Port Antenna with Circular Polarization Diversity," *IEEE Transactions on Antennas and Propagation*, vol. 57, no. 2, pp. 555-559, 2009.
- [4] S. H. Wi, Y. P. Zhang, H. Kim, I. Y. Oh and J. G. Yook, "Integration of Antenna and Feeding Network for Compact UWB Transceiver Package," *IEEE Transactions on Components, Packaging and Manufacturing Technology*, vol. 1, no.1, pp. 111-118, 2011.

- [5] S. Hebib and H. Aubert, "Triband antenna feeding circuit for circular polarization diversity," in *2011 41st European Microwave Conference*, Manchester, 2011, pp. 890-893.
- [6] J. L. Robert, P. Minard and A. Louzir, "Feeding Concept for a Multisector Antenna System," in *2008 38th European Microwave Conference*, Amsterdam, 2008, pp. 1102-1105.
- [7] A. H. Abdelrahman, F. Elhefnawi, A. Z. Elsherbeni, M. Hendi and S. Elramly, "Compact circularly-polarized microstrip array antenna," in *2010 Loughborough Antennas & Propagation Conference*, Loughborough, 2010, pp. 113-116.
- [8] C. H. Weng, H. W. Liu, C. H. Ku and C. F. Yang, "Dual circular polarisation microstrip array antenna for WLAN/WiMAX applications," *Electronics Letters*, vol. 46, no. 9, pp. 609-611, 2010.
- [9] D. Pozar, *Microwave Engineering*, 3rd ed. Hoboken, New Jersey: John Wiley & Sons Inc, 2005, pp. 308-361.
- [10] C. F. Chen, C. Y. Lin, B. H. Tseng and S. F. Chang, "Compact microstrip electronically tunable power divider with Chebyshev bandpass response," in *2014 Asia-Pacific Microwave Conference*, Sendai, Japan, 2014, pp. 1291-1293.
- [11] X. Y. Zhang, L. Gao and J. X. Xu, "Tunable power divider based on coupled resonator with high-selectivity filtering response," in *2015 IEEE MTT-S International Microwave Workshop Series on Advanced Materials and Processes for RF and THz Applications (IMWS-AMP)*, Suzhou, 2015, pp. 1-3.
- [12] X. Shen, Y. Liu, S. Zhou and Y. Wu, "A novel compact tunable coupled-line power divider using varactors," in *2015 Asia-Pacific Microwave Conference (APMC)*, Nanjing, 2015, pp. 1-3.
- [13] L. Guo, H. Zhu and A. M. Abbosh, "Wideband Tunable In-Phase Power Divider Using Three-Line Coupled Structure," *IEEE Microwave and Wireless Components Letters*, vol. 26, no.6, pp. 404-406, 2016.
- [14] Z. Guo, D. Jiang and H. Chen, "A compact tunable filtering-power divider based on liquid crystal," in *2015 IEEE International Conference on Communication Problem-Solving (ICCP)*, Guilin, 2015, pp. 416-418.
- [15] W. Zhou, T. Arslan, K. Benkrid, A. O. El-Rayis and N. Haridas, "Reconfigurable feeding network for GSM/GPS/3G/WiFi and global LTE applications," in *2013 IEEE International Symposium on Circuits and Systems (ISCAS2013)*, Beijing, 2013, pp. 958-961.
- [16] W. Zhou, T. Arslan and B. Flynn, "A reconfigurable feed network for a dual circularly polarised antenna array" in *2013 IEEE 24th Annual International Symposium on Personal, Indoor, and Mobile Radio Communications (PIMRC)*, London, 2013, pp. 430-434.
- [17] H. Chen, W. Che, Y. Cao, W. Feng and K. Sarabandi, "Function-Reconfigurable Between SPDT Switch and Power Divider Based on Switchable HMSIW Unit," *IEEE Microwave and Wireless Components Letters*, vol.27, no.3, pp. 275-277, 2017.
- [18] E. J. Wilkinson, "An N-Way Hybrid Power Divider," *IRE Transactions on Microwave Theory and Techniques*, vol. 8, no. 1, pp. 116-118, 1960.