

3D Platform Simulator Design Using Discrete Multi-Piston Actuators

Roche Alimin¹, Felix Pasila²

¹Department of Mechanical Engineering, Petra Christian University, Surabaya, East Java 60236, Indonesia.

²Department of Electrical Engineering, Petra Christian University, Surabaya, East Java 60236, Indonesia.
ralimin@petra.ac.id

Abstract—Generally, 3D simulator uses continuous feedback control system to control their actuator states. The objective of this article is to control the movement of actuators in compliance with 3D position required by simulator. This research uses discrete actuator for 3D simulator with four actuators that is open-loop controlled using Neuro-fuzzy control system. The actuator possesses linear pneumatic actuator with three pistons inside where each piston has independent intake. With the proposed design, the actuator able to give degree of discrete not only two (binary) values but also 26 combinations of discrete values. The 3D simulator proposed in this research have four actuators and two passives like-actuator. This configuration gives 4 degrees of freedom of platform movement. Applying force to the actuator using discrete output controller make possible to get more precise in terms of control and movement of the simulator that very useful for many force control applications.

Index Terms—3D Platform Simulator; Parallel Manipulator; Discrete Actuators; Inverse Static Analysis; Pneumatic Actuator.

I. INTRODUCTION

One of the advantages of parallel manipulator comparing with the serial one is its rigidity. Furthermore, it has more compact in size as well, especially for manipulator that has a degree of freedom more than three. With these excellences, many parallel manipulators were applied in Computer Numerical Control (CNC) machine tool and 3D simulator.

In 3D platform simulator application, the popular parallel manipulator is Gough-Stewart platform which developed and published in 1956 and 1965, respectively, in different area. In Gough-Stewart platform, the degree of freedom (*dof*) is six and the actuator used are six linear actuators. The *dof* will be reduced by x if there are x like-actuators among six actuators. Generally, a continuous feedback control system is used to control their actuator states [1, 2].

Based on the Gough-Stewart platform, this research develops a 3D platform simulator which using pneumatic discrete actuators. Pneumatic actuator uses pressure air as a working fluid so that the common way to control the actuator is using feedback control system with proportional type directional control valve and a linear encoder.

Currently, the only one method to solve the control problem for 3D simulator application is using Inverse Kinematic Analysis (IKA). Inverse Static Analysis (ISA) could not be used as additional control algorithm in order to give control that is more precise. This is because of the pressure of working fluid inside the actuator is almost constant. The constant pressure will give the constant force as well. This research proposes a solution in order to make

one actuator could give variable discrete force. The solution is using multi piston inside one actuator.

In order to fulfill the new design actuator, the control method is changed. Discrete control is applied to make the actuator become a discrete force generator [3, 4]. As a result, the 5/3 directional control valve is used instead of the proportional one. Also, cheaper hardware and simpler solution for Inverse Static Analysis of 3D simulator platform can be applied by only open-loop control system using Neuro-fuzzy control system.

Previous studies which are closely linked to the control of discrete parallel manipulator using neuro-fuzzy control system was proposed by Pasila, et al. [3, 5]. This study focused on controlling the six *dof* parallel manipulator using the Neuro-fuzzy architecture. Another example of parallel manipulator that has binary in activating the actuators can be seen on [6-8].

II. RESEARCH METHODOLOGY

The research methodology in this paper is divided into three Sections. Section A is about the designing of the multi pistons actuator, while Section B is about the designing 3D platform simulation that using the actuators, both are using CAD software. The last section C is about a proposed methodology to solve Inverse Static Analysis of the platform.

A. The Design of Multi Pistons Actuator

The multi pistons actuator consists of main components: the cylinder that has multi holes as many as the sum of piston, the pistons, the rods, the main-rod, the cap-end port, and the rod-end port. In this research, the actuator has 3 pistons. Each piston is controlled by one directional control valve, separately with other pistons. The actuator is double action type and the directional control valve is 5/3 solenoid type with free flow spring centered. Each piston has its rod and on the top of the rods is connected together to the main-rod.

Figure 1 depicts the actuator with its components. In order to get a uniform step variation of force, the piston annulus area is designed to have half of piston bore area. That is means each piston will give extended force two times bigger than its retracted force.

The actuator is designed to be discrete actuator and is controlled using discrete way system control as well. For this reason, each piston has three states: extended, floated, and retracted. Because of having three pistons, the actuator will have $3^3 = 27$ variation of forces. Actually, the variation is less than 27. This is because of stability reason whose states that all of pistons should not in floating state at the same time. Otherwise, the platform will be unstable.

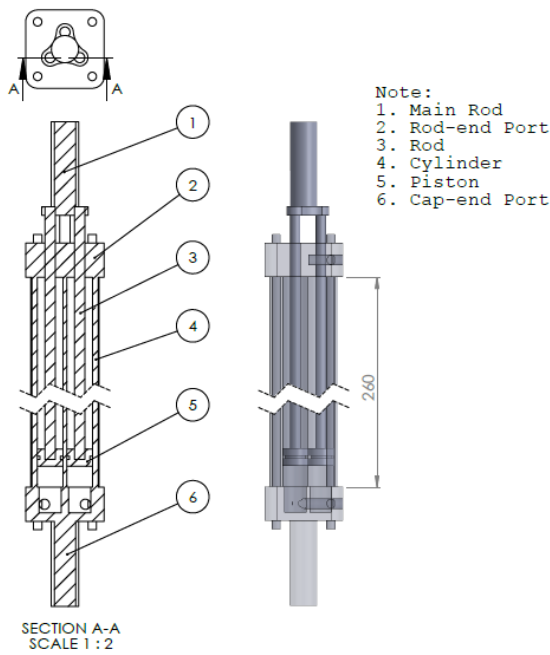

Figure 1: Multi Piston Pneumatic Actuator

B. Design of 3D Platform Simulator

The 3D platform simulator design in this paper consists of a pair of body: the upper body that serves as a moving platform and the lower body serves as a fixed body, which is connected by six multi-piston pneumatic actuators. The upper body and the lower body are constructed according to the Gough-Stewart platform principle.

There is one thing that must be considered to determine whether the platform manipulator will experience unstable or not, that is not every installed actuator should be in floating state. If one of actuators in floating state, it means there is one degree of freedom of the platform in unstable condition. Therefore, three pistons inside an actuator should not be in floating state in the same time. Figure 2 depicted the 3D platform simulator. The platform uses four actuators that serve as prismatic joint and 2 links. Therefore, the platform has four *dof*. Three pieces Directional Control Valve (DCV) controls each of actuator so that each piston will be able to be controlled independently. All of actuators and links are connected to the upper body and the lower body using universal joints to form Universal-Prismatic-Universal-Revolute (UPUR) construction. In this case, the lower universal joint can rotate with respect to the lower platform, performing similarly to a spherical joint. The actuator purely acts as prismatic joint. It could not perform rotation because of its design.

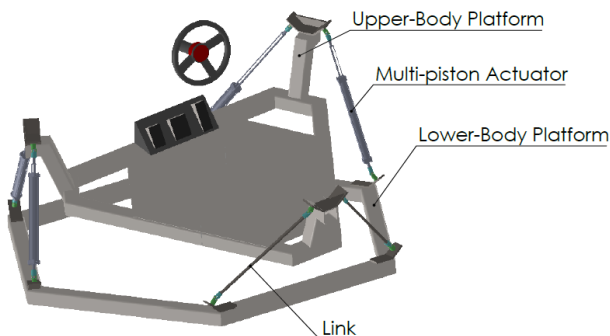

Figure 2: Three Dimension Platform Simulator

Moreover, the proposed platform simulator should have specifications of both bodies, as shown in Table 1 and the actuators and links, as shown in Table 2.

Table 1
Specifications of The Platform Simulator

Material	Steel	-
Mass the upper body	153	kg
Mass the lower body	67	kg
Circle Diameter between Joints of the upper body	1800	mm
Circle Diameter between Joints of the lower body	2300	mm

Table 2
Specifications of The Actuators And Links

Pneumatic Actuator		
Material	Aluminium	-
Mass	2315	gr
Stroke	400	mm
Piston diameter	15	mm
Link		
Material	Steel bar	-
Mass	947	gr
Link diameter	16	mm
Link tall	600	mm

Actuators used are custom dual action type pneumatic actuators with 250 mm stroke and 15 mm bore and work at air pressure range of 6-8 kg/mm². Both ends of the actuators are connected to the universal joints through bar diameter 16 mm, made by ST60 steel.

Joints between actuators and platform can be spherical or universal joints. In this case, the universal joint was chosen. The reason is more rigid and easy to get. In actuator part, that is the multi-piston cylinder; the three pistons could not rotate inside the cylinder. As a compensation, the universal joint must have 3 *dof*. It means one of the end side of the universal joint, either connector between universal joint - upper platform or connector between universal joint - actuator, must have a rotary joint. Figure 3 shows the picture of the universal joint.

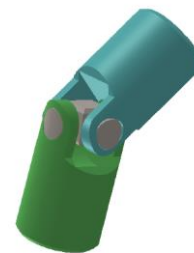

Figure 3: The Universal Joint

Every actuator consists of one of cylinder and three of pistons. The three pistons move dependently, but each of the pistons is supplied of compressed air independently. Therefore, each piston must be controlled by a Directional Control Valve as a last control element of electro-pneumatic system which is controlled by digital output of Programmable Logic Controller (PLC). For the proposed simulator platform which has 4 actuators, 12 digital output of PLC is needed. Figure 4 depicted pneumatic circuit diagram of the simulator, shown for one actuator only.

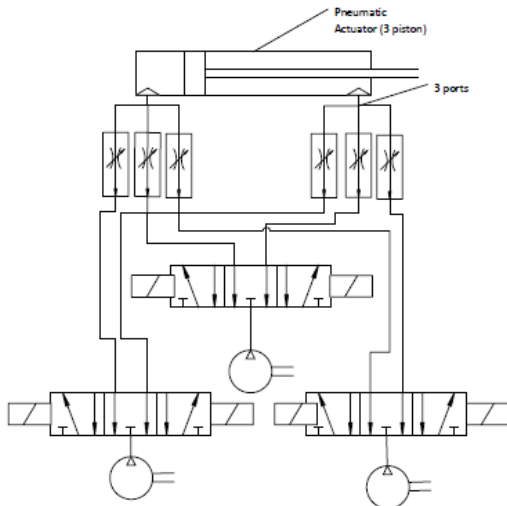

Figure 4: The Pneumatic Circuit Diagram

C. Methodology to Solve Inverse Static Analysis of the Platform

The platform simulator is planned to be controlled discretely using Neural Network as ISA solution for the simulator. The performance of the discretely controlled manipulator is expected to resemble the analogue controlled manipulator. The first step, simulation of CAD solid model of the platform simulator is conducted by using CAD Simulation Software. The software is used to look for the limit of translation and rotation movement between the moving platform and the fixed platform of the design without any interference happen between platforms, actuators and joints. The limit is the constraint of the platform simulator design.

Data for training neuro-fuzzy control is generated by using forward static analysis analytically. Based on the data of geometry design of the platform simulator, depicted in figure 5-7, calculation of force at the end effector of the parallel manipulator, that is in the centroid of the moving platform, is conducted using vector-loop principle for every limb (actuator or link).

$$d_i = \sqrt{[\mathbf{p} + R_B^A \mathbf{b}_i^B - \mathbf{a}_i]^T [\mathbf{p} + R_B^A \mathbf{b}_i^B - \mathbf{a}_i]} \quad (1)$$

where: d_i = the length of i -th limb.

\mathbf{p} = position vector of centroid of the moving platform (the end effector).

R_B^A = rotation matrix of the moving platform with respect to fix platform (Euler angle).

\mathbf{a}_i^B = position vector of lower joint point (centroid of the fix platform to lower universal joint).

\mathbf{b}_i^B = position vector of upper joint point (centroid of the moving platform to upper universal joint).

Hence the total force acting on the moving platform by each limb can be written as

$$\mathbf{f} = \sum_{i=1}^6 f_i \mathbf{s}_i \quad \text{for } i = 1, 2, \dots, 6. \quad (2)$$

where: \mathbf{f} = the total force.

f_i = force generated by each limb (actuator).

\mathbf{s}_i = unit vector pointing from the lower universal joint to the upper universal joint, that is connected by a limb.

Then six linear scalar equation in f_i which can be written in matrix form as

$$[\mathbf{f}] = [\mathbf{s}_1 \mathbf{s}_2 \dots \mathbf{s}_6][f_1 f_2 \dots f_6]^T \quad (3)$$

Hence given the actuator forces, the end effector (the centroid of the moving platform) output can be computed directly.

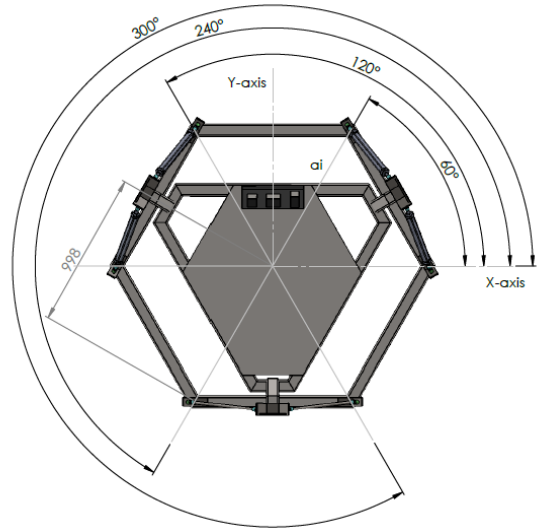

Figure 5: Position of Centroid of the Fix Platform Among the Lower Universal Joints

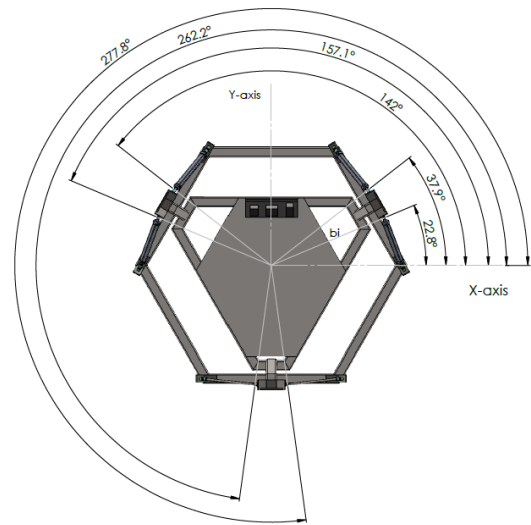

Figure 6: Position of Centroid of the Moving Platform (the End Effector) Among the Upper Universal Joints

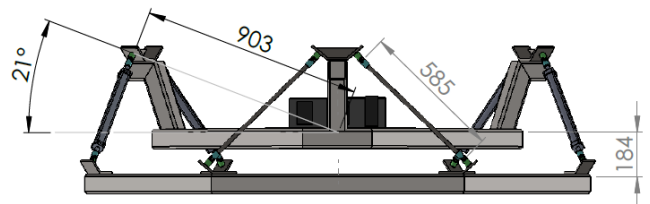

Figure 7: Home Position of the Platform Simulator

In the first step, various of input data is generated and then performing forward static calculation. Both are conducted by using the *Matlab* software. As the input data are translation and rotation of the end effector, and also the force of each actuator. And as the output is the force at the end effector. After enough number of data have been collected, the second step is to use the data for training the neuro-fuzzy control system. The AI network will be trained until the network has learned the most important information for prediction step. High enough number of data will make the network trained well in a specific region. Reaching the local minimum of the objective function is accepted as the training efficiency merit [3] so that after reaching this minimum value, the error function will steadily decrease. It will indicate that the training iteration can be stopped.

III. RESULTS AND DISCUSSIONS

The data generated from Matlab software consists of two signals. The first signal is the data of total force at the end effector and the second signal is the neuro-fuzzy model generated from methods that explained in [3].

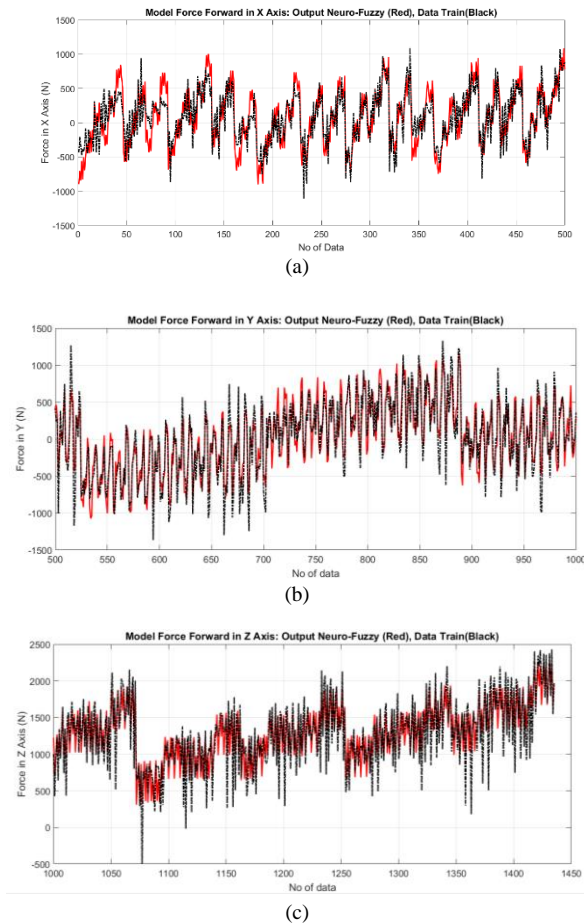

Figure 8: Generating data of Total Force compared with the Neuro-Fuzzy Model in Axis X (a), Axis Y (b) and Axis Z(c)

All forces at the end effector are calculated via a combination of the known parameters and chosen by the interval, so the data collected is only 1435 data from the huge number of the possible combination. The view of force in X, Y and Z axis and their neuro-fuzzy model can be shown in Fig.8. The Root Mean Squared Error (RMSE) of the 1435 data is calculated via training of neuro-fuzzy model and the results of RMSE is 0.0648.

IV. CONCLUSION

As a conclusion, this paper discusses the design of 3D simulator platform presented: 1) discrete actuator for a 3D simulator with four actuators that are controlled in open loop way; 2) the actuator possesses linear pneumatic actuator with three pistons inside where each piston has an independent intake. The proposed design of the actuator could give not only degree of discrete two (binary, 1 or 0) values but also 26 combinations of discrete values.

The conclusion that can be drawn from this research-based from the value of the RMSE is that the 3D Simulator platform is designed in this research works relatively well with mechanical training error RMSE = 0.0648 or below 7%.

ACKNOWLEDGEMENT

All authors would like to thank Department of Higher Education of Indonesia (Menristek-Dikti) for supporting this research with number 25/SP2H/PDSTRL_Pen/LPPM-UKP/IV/2016.

REFERENCES

- [1] Gough V.E., "Contribution to discussion of papers on research in Automobile Stability, Control and Tyre Performance". *Proc. Auto Div. Inst. Mech. Eng.:* 392–394, 1956-1957.
- [2] Stewart D., "A Platform with Six Degrees of Freedom". *Proc. Institution of Mechanical Engineers (UK)*. 180 (Pt 1, No 15), 1965–1966.
- [3] Pasila F, Alimin R., "Applications of artificial intelligence control for Parallel Discrete-Manipulators", International Conference on Advanced Informatics: Concepts, Theory and Application, ICAICTA 2016; Penang, Malaysia, 2016
- [4] Pasila F., Alimin R., Natalius H., "Neuro-Fuzzy Architecture of the 3D Model of Massive Parallel Actuators", *ARPN Journal of Engineering and Applied Sciences*, vol. 9, pp. 2900-2905, 2014.
- [5] Pasila F., Alimin R., "Coordinates modelling of the discrete hexapod manipulator via artificial intelligence", Lecture Notes in Electrical Engineering Vol 365, Pages 47-53, Springer, 2016
- [6] Ioannis D., Papadopoulos E., "Model-based control of a 6-dof electrohydraulic Stewart–Gough platform", *Mechanism and Machine Theory* 43, pp.1385–1400, Elsevier, 2008
- [7] Yang P., Waldron K.J., "Massively Parallel Actuation", 2001 IEEE/ASME International Conference on Advanced Intelligent Mechatronics, pp. 868-873, 2001.
- [8] Lichter D., Sujun V.A., Dubowsky S., "Computational Issues in the Planning and Kinematics of Binary Robots", *Proceedings of the 2002 IEEE International Conference on Robotics and Automation*, pp. 341-346, 2002.