

# Determination of Sugar Level and the Existence of Magic Sugar in Various Beverages using a Glucose Meter with Four-Point Probe and Electrochemical Impedance

Febus Reidj Cruz<sup>1</sup>, Jennifer C. Dela Cruz<sup>1</sup>, Regil Ken L. Castillo<sup>1</sup>, Francheska Nichole G. Cave<sup>1</sup>,  
John Patrick F. Frias<sup>1</sup>, Paolo Joshua Torreno<sup>1</sup> and Zaliman Sauli<sup>2</sup>

<sup>1</sup>*School of Electrical, Electronics and Computer Engineering, Mapua University, Intramuros, 658 Muralla St., Intramuros, Manila 1002, Philippines.*

<sup>2</sup>*School of Microelectronic Engineering, Universiti Malaysia Perlis, Pauh Putra Campus, 02600 Arau, Perlis, Malaysia  
frgcruz@mapua.edu.ph*

**Abstract**— Nowadays, people are being inconsiderate about the healthy lifestyle that might lead us to be unhealthy and be prone to developing tumors in the kidney due to some kind of sugar being used. In order to minimize these problems, the team will raise people awareness. Raising people awareness is not the same as telling them what to do. It is about giving them the knowledge to let them decide for themselves. This is why the team developed a device that can measure the sugar level and determine the existence of magic sugar in various beverages. The device is composed of two major parts: first is the circuit that will measure the impedance of a liquid sample and second, is a four-point probe, which includes a microcontroller that will display and interpret the results. The Four-point probe applies the concept of Wenner method and Electrochemical Impedance. After constructing the device, the team performed its calibration that requires different liquid samples. Based on its gathered data, different graphical representations were formulated and translated into mathematical equations in order to integrate it onto the microcontroller. Whenever the microcontroller encounters an unknown solution, it can determine the sugar level and classify the type of sugar being used.

**Index Terms**— Four-Point Probe; Wenner Method; Sodium Cyclamate; White Sugar; Brown Sugar.

## I. INTRODUCTION

The Nowadays, people are being inconsiderate about the healthy lifestyle that might lead us for being unhealthy and are prone in developing tumors in the kidney due to some kind of sugar being used by local vendors in the streets. The harmful contents of different beverages such as the excessive amount of sugar and sodium as well as its fats and calories make people more mindful of what they consume. Several studies about the same dilemma are already published in the industry but every study has its own limitation. As for one of the related literature, an equivalent circuit is employed in the characterization of the impedance measurements of different liquid samples using three electrodes cell to measure the impedance of each sample [1] accurately.

A certain study about the determination of sugar content in sugar solutions using an inter-digital capacitor sensor has effectively obtained the suitable frequencies of the voltage source for the proposed system which are the frequencies of 120-300 kHz to obtain the large output voltage differences between 10 % and 50 % sugar concentration [2].

In order to minimize these kinds of problems in our society, we developed a device that will help us to measure the sugar level of a particular liquid sample and identify if it contains sodium cyclamate before consuming it. In that manner, we can avoid too much intake of sugar as well as the consumption of sodium cyclamate. In order to be more distinct, this study focuses on determining whether the various beverages locally available in the market contain sodium cyclamate, also known as Magic Sugar, and to determine the sugar level of the drink itself using the four-point probe and Electrochemical Impedance Spectroscopy [3-4].

Knowing the content of the specific beverage whether it comprises the so-called “magic sugar” before drinking it is an important indicator to judge the quality of the beverage. Most of the current sugar-detecting devices use only frequency as its main parameter in order to determine the sugar content. To make things clearer, the varying parameter for this study is the voltage with respect to its sugar content. Lastly, none of the related topics are flexible enough to determine whether the sugar itself contains sodium cyclamate or not. Although, we seldom encounter this kind of problem, still, it is best to be wise on the drinks that we intake to our body.

A four-point probe is an ingenious tool for quantifying the resistivity of semiconductor samples. The measurement of the substrate resistivity is done where the current is passed through the outer probes and the voltage is measured through the inner probes. The doping concentration can be calculated from the resistivity using formulas depending on the sample itself specifically bulk or thin specimen each with a different expression.

Four-point probe method can be used to measure either a rectangular or a circular sample. The two outer probes will serve as the dipole while the inner probes will have a potential difference, and these will result in the sheet resistivity of the sample. Aside from thin sheets, four-point probe method can also be used to measure the body resistivity of a sample provided by a thickness value [5-6].

The Wenner Method, a different approach of four-point probe, is a common procedure to obtain the resistivity of soil. It involves the use of electrodes with equal spaces between each other plunged in the soil. Other methods such as Schlumberger and driven rod also use four electrodes but they differ in the spacing of each electrode.

Based on the technique of utilizing four electrodes, the two electrodes are utilized for current injection and two are utilized for voltage measurement. The four electrodes embedded to the ground in a straight line, the two outer electrodes are a current electrode and two inner electrodes to measure voltage drop due to the resistance of soil path when current passed between the outer electrodes [7].

Combining all these concepts and techniques, an electronic system for measuring the sugar level and the existence of magic sugar, which is also known as sodium cyclamate in various beverages will be obtained. The main objective of this study is to design an electronic system to measure the sugar level and to verify the existence of sodium cyclamate in a liquid sample using the Four-Point probe and Electrochemical Impedance Spectroscopy method. In order to complete this system, the team will design and develop a circuit that will convert the voltage reading from a liquid sample into an impedance value. Based on its calibration on different liquid samples, the system will also be able to classify the type of sugar that is being mixed in the concoction [8].

## II. METHODOLOGY

This part discusses the system process as well as the framework of the study. Detecting the impedance of different liquid samples by the concept of the four-point probe analysis and electrochemical impedance spectroscopy is the heart of the study. Possible algorithms related to the study were identified. In addition, the design of an equivalent circuit and the type of sensor to be used was established in order to further examine the choice of liquid samples and to perform calibration within the limited number of liquid samples. In the implementation of methods, two methods were used namely: four-point probe and electrochemical impedance spectroscopy with the support of enzymatic methods and Wenner method. For completing the research methods, an electronic system or device has been developed for the determination of glucose level and detection of the magic sugar.

The liquid sample will be probed using the device, in which it may respond or not. In case the device does not respond, troubleshooting is needed. When the device responds, it will then measure the voltage of the sample and then compare if it matches from the database. If the value does not match, the device needs to be recalibrated. If it does match, the LCD will display the output and identify the type of sugar used in the sample. Please refer to Figure 1 for the process flow.

The use of the Operational Transconductance Amplifier (OTA) is to use the differential input voltage and produce an ideal constant output current hence the name, voltage-to-current amplifier. The first two resistors, R1 and R2, are used as a voltage divider

$$V_{out} = V_{in} \left( \frac{R2}{R1 + R2} \right) \quad (1)$$

whereas  $V_{in}$  is the voltage from the supply, which is a 9V battery, R1 and R2 as the resistors needed to produce an approximately constant output voltage, which is expected to be 5V. Figure 2 shows a schematic diagram of the current source using operational transconductance amplifier.

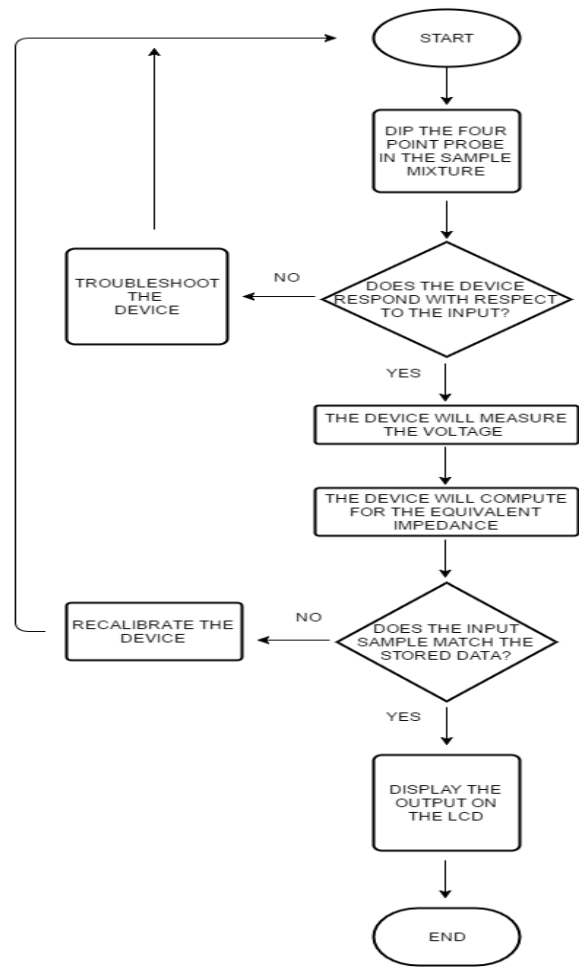

Figure 1: Process flowchart

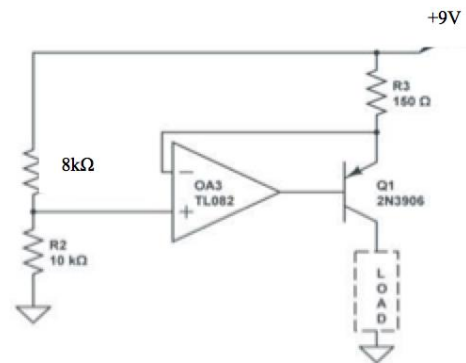

Figure 2: Schematic diagram of the current source using Operational Transconductance Amplifier.

TL082 is a wide bandwidth dual JFET Operational Amplifier wherein it is a low cost, high speed with internally trimmed input offset voltage and provides low input bias and offset currents which fit the type of current source that group wants to obtain. Lastly, 2N3906 is a commonly used PNP bipolar junction transistor intended for general purpose low-power amplifying applications. The real intention of this passive device is to act as a switch so that it turns on when the required voltage is met and turns off if it does not. The load from Figure 2 is connected to the microcontroller so that it can project the readings in the serial monitor. Figure 3 illustrates the flow for calibration. Thus, prior to performing calibration, all water solutions should be properly mixed and

placed into the prototype made. Testing on different liquid samples is done by dipping the probe into the solution and let the microcontroller do the readings. Record all data in Microsoft Excel and generate the graph. After which, the range of voltages should be indicated so that proper classification of sugar is correct. The relationship can be clearly seen in the graph from the data gathered. The algorithm of the program is dependent on the mathematical equation produced depending on the data. After the mathematical equation has been generated, it would be uploaded to the microcontroller so that it would know what voltage range, the type of sugar and the amount of sugar.

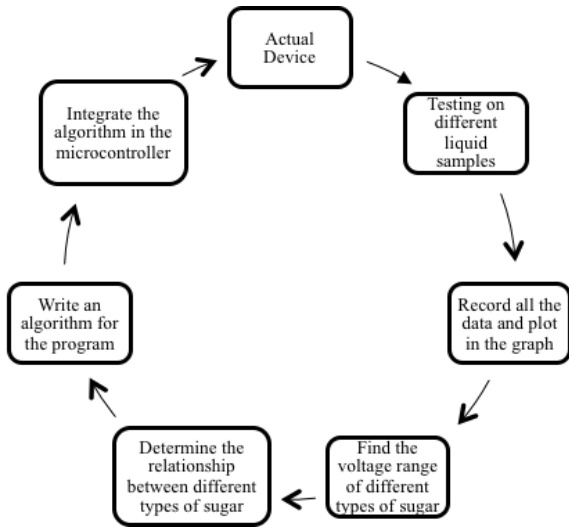

Figure 3: Schematic diagram of the current source using Operational Transconductance Amplifier.

### III. RESULT AND DISCUSSION

Following are the results and discussions derived from the experiments. As seen in Figure 4, the amount of sugar in grams is inversely proportional to the voltage obtained. The white, brown and magic sugar shows decreasing voltage from 1.5114V to 1.0114V, 0.7936V to 0.3863V and 0.1595V to 0V respectively, as the amount of sugar increased.

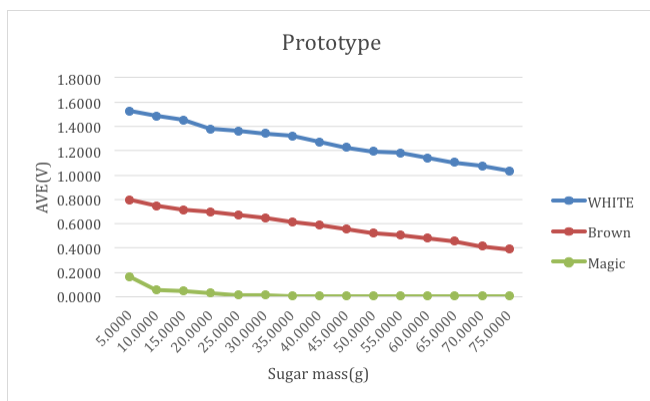

Figure 4: Prototype reading for average voltage versus sugar mass

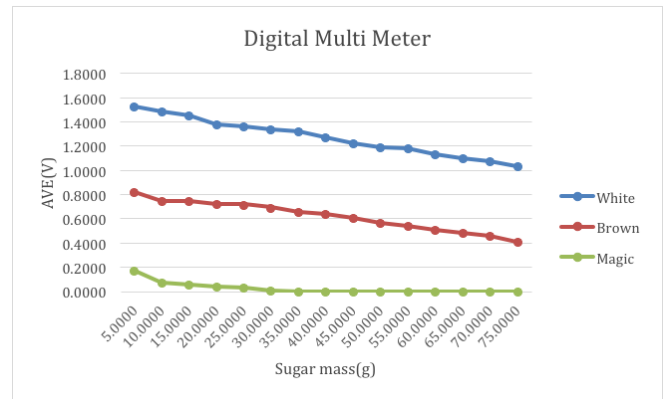

Figure 5: Digital multi meter reading for average voltage versus sugar

Table 1  
Average Voltage Readings (V) of the Prototype and DMM using White, Brown, and Magic Sugar

Amount (g)	White		Brown		Magic	
	Proto	DMM	Proto	DMM	Proto	DMM
5.0	1.5114	1.5290	0.7936	0.8200	0.1595	0.1721
10.0	1.4642	1.4903	0.7482	0.7447	0.0546	0.0739
15.0	1.4183	1.4520	0.7136	0.7493	0.0427	0.0536
20.0	1.3511	1.3797	0.6976	0.7190	0.0299	0.0435
25.0	1.3427	1.3613	0.6697	0.7172	0.0150	0.0303
30.0	1.3197	1.3430	0.6469	0.6933	0.0090	0.0094
35.0	1.2919	1.3254	0.6133	0.6582	0.0000	0.0000
40.0	1.2483	1.2730	0.5879	0.6387	0.0000	0.0000
45.0	1.2058	1.2280	0.5548	0.6074	0.0000	0.0000
50.0	1.1794	1.1947	0.5212	0.5690	0.0000	0.0000
55.0	1.1604	1.1800	0.5035	0.5375	0.0000	0.0000
60.0	1.1180	1.1377	0.4826	0.5094	0.0000	0.0000
65.0	1.0722	1.1037	0.4551	0.4855	0.0000	0.0000
70.0	1.0357	1.0757	0.4157	0.4607	0.0000	0.0000
75.0	1.0114	1.0364	0.3863	0.4103	0.0000	0.0000

Table 2  
Comparison between Prototype and DMM Voltage Readings using White, Brown, and Magic Sugar

	White		Brown		Magic	
	Proto	DMM	Proto	DMM	Proto	DMM
Mean (g)	1.2487	1.2740	0.5860	0.6213	0.0207	0.0255
Variance	0.0239	0.0236	0.0156	0.0149	0.0018	0.0022
Pearson	0.9990		0.9929		0.9929	
Correlation						
$t_c$	-13.9843		-9.1035		-2.5896	
$t_{tab}$	1.7613		1.7613		1.7613	
p-value	0.0000		0.0000		0.0107	
Statistical test used: one-tailed t-test for paired samples						
Level of significance( $\alpha$ ): 5%						
Decision Rule: Reject null hypothesis if p-value < $\alpha = 0.05$						

As seen in Figure 6, three mathematical equations were generated by the use of Microsoft Excel whereas the voltage, in V, can be seen in the horizontal axis part of the graph and sugar mass, in g, as the vertical axis part of the graph. The trend line for all the types of sugar is inversely proportional wherein as the mass of the sugar increases, the voltage reading is decreasing. Represent

$$y = -144.0x + 219.9 \quad (2)$$

Equation (2) serves as the linear mathematical equation for white sugar where  $y$  characterizes the amount of sugar, in g, while  $x$  represents voltage, in v.

$$y = -178.8x + 144.7 \quad (3)$$

Equation (3) serves as the linear mathematical equation for brown sugar where y characterizes the amount of sugar, in g, while x represents voltage, in v.

$$y = -143.8x + 24.94 \quad (4)$$

Equation (4) serves as the linear mathematical equation for magic sugar where y characterizes the amount of sugar, in g, while x represents voltage, in v.

A parameter of R<sup>2</sup> can also be seen whereas it symbolizes how precise the data gathered is with reference to the generated mathematical equation. The closer it gets to a value of 1, the more precise the gathered data is. The team got 0.992, 0.997 and 0.727 as the R<sup>2</sup> values for white sugar, brown sugar and magic sugar respectively.

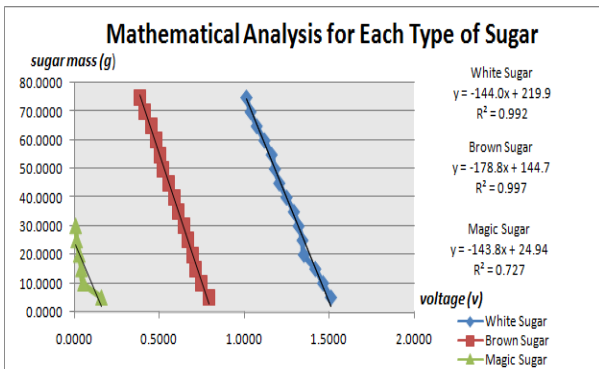

Figure 6: Mathematical Analysis for Each Type of Sugar

Table 3  
Comparison of Actual and Prototype Readings of Liquid Samples

Liquid Samples	Actual		Prototype Reading	
	Amount of Sugar in Grams	Type of Sugar Used	Amount of Sugar in Grams	Type of Sugar Used
Mango	5	White	5.30	White
Coconut	10	White	10.20	White
Young Coconut with Pandan leaves	15	White	15.29	White
Coffee Jelly	5	Brown	5.81	Brown
Mango	5, 10	White, Magic	5.20 / 10.20	White, Magic
Coconut	10, 20	Brown, Magic	10.20/20.30	Brown, Magic
Young Coconut with Pandan leaves	5, 15	White, Magic	5.20/15.20	White, Magic
Coffee Jelly	5, 5	Brown, Magic	5.20/5.20	Brown, Magic

The testing of the prototype to the actual liquid samples is just the same as the calibration of different types of sugar in water solutions whereas the team bought different beverages and incorporated known amount and type of sugar in the beverage and tested whether the prototype is sensitive enough to do so. As seen in Table 3, the prototype did determine the amount and type of sugar contained in the beverage. The microcontroller will read a specific output voltage to the liquid sample and after a few moments, it will display the amount and type of sugar. The microcontroller is smart enough to project an exact amount of sugar with its corresponding output voltage based on the range of voltages as well as the mathematical equations encoded to it [6].

#### IV. CONCLUSION

By thoroughly researching the concepts behind Four-Point Probe and Electrochemical Impedance Spectroscopy as well as the help of Wenner Method, the team was able to design and develop a circuit that can measure the impedance of a liquid sample by performing proper calibration on different liquid samples and establishing the proper sensor to be used. The proposed design consists of a constant current source, whereas an Operational Transconductance Amplifier was used, and a voltmeter as indicated by the Four-Point Probe and Electrochemical Impedance Spectroscopy method.

#### REFERENCES

- [1] S. Khan, S. M. A. Rizvi, and S. Urooj, "Equivalent circuit modeling using electrochemical impedance spectroscopy for different materials of SOFC," in *Computing for Sustainable Global Development (INDIACom), 2016 3rd International Conference on*, 2016, pp. 1563–1567.
- [2] N. Angkawisittpan and T. Manasri, "Determination of sugar content in sugar solutions using interdigital capacitor sensor," *Meas. Sci. Rev.*, vol. 12, no. 1, pp. 8–13, 2012.
- [3] O. Olarte, K. Barbe, W. Van Moer, and Y. Van Ingelgem, "Glucose characterization based on electrochemical impedance spectroscopy," in *Instrumentation and Measurement Technology Conference (I2MTC) Proceedings, 2014 IEEE International*, 2014, pp. 833–837.
- [4] Y. Yao, Z. Jia, and M. Liu, "Nondestructive inspection of melon's sugar content based on impedance characteristics," *Adv. Sci. Lett.*, vol. 19, no. 6, pp. 1572–1575, 2013.
- [5] F. M. Smits, "Measurement of sheet resistivities with the four-point probe," *Bell Labs Tech. J.*, vol. 37, no. 3, pp. 711–718, 1958.
- [6] D. K. Schroder, *Semiconductor material and device characterization*. John Wiley & Sons, 2006.
- [7] M. Shaban, M. A. Salam, S. P. Ang, and W. Voon, "Induced sheath voltage in power cables: A review," *Renew. Sustain. Energy Rev.*, vol. 62, pp. 1236–1251, 2016.
- [8] A. Vega-Gálvez, M. Miranda, J. Vergara, E. Uribe, L. Puente, and E. A. Martínez, "Nutrition facts and functional potential of quinoa (Chenopodium quinoa willd.), an ancient Andean grain: a review," *J. Sci. Food Agric.*, vol. 90, no. 15, pp. 2541–2547, 2010.
- [9] M. Cao, Z. Li, J. Wang, W. Ge, T. Yue, R. Li, V. L. Colvin, and W. Y. William, "Food related applications of magnetic iron oxide nanoparticles: enzyme immobilization, protein purification, and food analysis," *Trends Food Sci. Technol.*, vol. 27, no. 1, pp. 47–56, 2012.