

A NOVEL HYBRID NOTCH (HN) SUBSTRATE INTEGRATED WAVEGUIDE (SIW) BANDSTOP FILTER

A. Badrul Hisham, M. N. Husain, K. S. Tan

Faculty of Electronic and Computer Engineering
Universiti Teknikal Malaysia Melaka, Malaysia

badrulhisham@utem.edu.my, drmohdnor@utem.edu.my,
tankim@utem.edu.my

Abstract

The advent of substrate integrated waveguide has seen an influx of researches on the study and design of microwave filters employing such a technique[1]-[4]. This technique provides an excellent avenue to design millimeter wave circuits such as filters, resonators and antennae[5]. A great advantage is that these devices can be easily connected to other planar microwave transmission lines and devices by using very simple transitions[6]. While many researches on SIW primarily focused on bandpass filters, researches on SIW bandstop filters for the GHz frequency ranges are gaining momentum working on the big list of advantages of SIW over microstrips. This paper presents the analysis and design of a novel Hybrid Notch Bandstop Filter working in the X-Band of the Frequency Spectrum.

Keywords: Microwave filters, Substrate Integrated Waveguide, Hybrid Notch, Bandstop Filter

I. INTRODUCTION

In a communication system, bandpass and bandstop filters play very important in discriminating between the desired and the unwanted signals. While bandpass filters allow the desired signal to go through, the bandstop filters are designed to reject or suppress a certain band of frequencies. This distinction had been in practice from the start, where lump elements of L and C were configured to be either passband filters or bandstop filters. However, as the communication systems demand greater use in the microwave region for the transmission of such signals, the inefficiency of the

lump elements as bandpass and bandstop filters could no longer support the quality and performance of the microwave communication systems. As a result rectangular waveguides have been widely used to realize low-insertion losses, high Q, and high-power handling capacities in the microwave and millimeter-wave communication systems. However, rectangular waveguides are large and costly. The discovery of a metalized planer substrate with two parallel rows of via holes with precise holes diameter and periodic holes separation, to be known as substrate integrated waveguide, that displays the properties of rectangular waveguides opened the floodgate for researches. Substrate integrated waveguide is a waveguide that synthesizes inside a substrate and the propagating waves are delimited by arrays of via holes[7]-[10]. This paper presents the analysis and design of a novel Hybrid Notch(HN) SIW bandstop filter exploiting on the many benefits of SIW, such as having a high Q, low insertion loss, reduced size, low cost and easily to be integrated with planar circuits[11].

II MATERIALS AND METHOD

The substrate integrated waveguide (SIW) resonator was first proposed by Piolote, Flanik and Zaki which developed the idea of replacing the waveguide walls with a series of metallic holes via through the substrate to achieve the same effect of metallic wall[12]-[13]. As the initial dimension, the size of the substrate integrated waveguide cavity

is determined by the corresponding resonance frequency [14],

$$f_{101} = \frac{c}{2\pi\sqrt{\mu_r\epsilon_r}} \sqrt{\left(\frac{\pi}{w_{eff}}\right)^2 + \left(\frac{\pi}{l_{eff}}\right)^2}$$

where w_{eff} and l_{eff} are the equivalent width and length of the SIW cavity which can be expressed as:

$$w_{eff} = w - \frac{d^2}{0.95p}, \quad l_{eff} = l - \frac{d^2}{0.95p}$$

where w and l are real width and length of the SIW cavity, d and p are the diameter of the via holes and distance between adjacent via holes respectively, c is the velocity of light in free space, μ and ϵ_r are the relative permeability and relative permittivity of the substrate respectively.

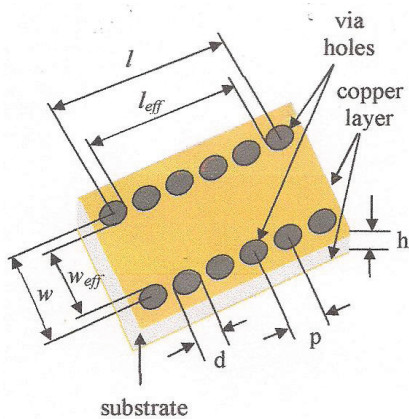

Figure 1 Substrate integrated waveguide (SIW)

Figure 1 shows the configurations of dimensions in a substrate integrated waveguide.

For SIW, the TM mode cannot be guided because of the extremely thin thickness of the substrate[15]. Only the TE mode is the sole propagating mode. In SIW, TE_{101} is dominant.

The design of Hybrid Notch Filter combines an impedance inverter network connected across a two-port network SIW bandpass filter. In its simplest form, the impedance inverter network comprises an impedance inverter of a substantial $\sqrt{2}$ characteristic admittance connected between the input and output ports, across which the two port filter network is connected, and impedance inverters of a substantial unity characteristic admittance interconnecting the $\sqrt{2}$ characteristic admittance impedance inverters at their respective ends.

The research was first achieved using software simulation. All simulation work is done using current available design software. After having obtained the simulated results which display the properties of a bandstop filter, a prototype Hybrid Notch SIW Bandstop Filter is developed.

The HN SIW Bandstop Filter prototype is developed using a standard PCB process with substrate of the Rogers RO 4350, with a thickness of 0.5 mm, dielectric permittivity, ϵ_r of 3.48, dissipation factor, $\tan \delta$ of 0.04, and copper thickness of 35 μm . The diameter of the via holes is 0.5 mm and the distance between adjacent via holes is 1.44 mm. The structure is mounted on an aluminum block and tightened by screws to enhance the ground plane.

The measured results are taken and comparisons made with the simulated results to see the compatibility of the simulated and measured results. Further improvement is expected to change the variables involved to achieve the best response of a bandstop filter. Figure 2 shows a model of a Hybrid Notch Bandstop Filter. It uses two-stage branch line couplers and the filter utilizes the SIW bandpass filter.

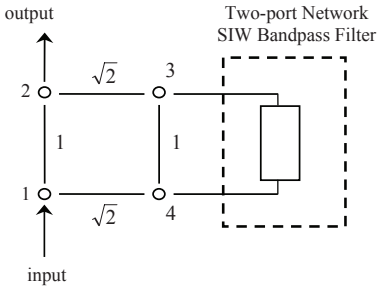

Figure 2 A Model of the Hybrid Notch Bandstop Filter

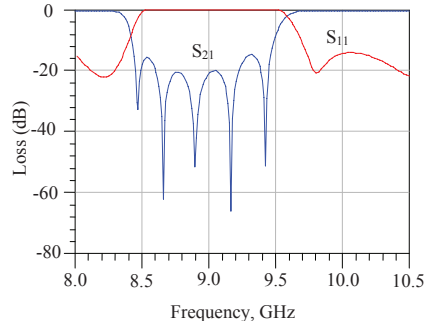

Figure 4 Frequency Response of the Lumped Equivalent Circuit of a HN SIW Bandstop Filter

II SYNTHESIS OF A LUMPED EQUIVALENT FOR HN SIW BANDSTOP FILTER

The circuit for the lumped equivalent circuit is shown in Figure 3. A two stage line coupler is connected directly to a lumped two-port network SIW bandpass filter. This lumped equivalent circuit is simulated and the frequency response is shown in Figure 3.

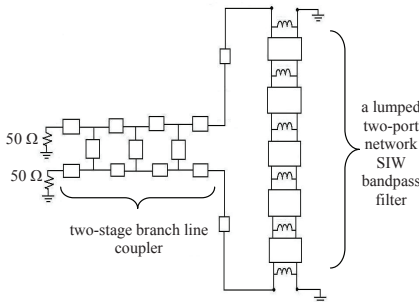

Figure 3 A Lumped Equivalent Circuit for HN SIW Bandstop Filter

III REALIZATION OF HN SIW BANDSTOP FILTER

Figure 5 shows a three-dimensional layout of the physical realization of the Hybrid Notch SIW Bandstop Filter. The two-stage branch coupler is connected directly to the two-port network SIW bandpass filter. It is then simulated using advance design software to validate the theoretical and the simulated results. Figure 5 shows the simulated frequency response of the HN SIW Bandstop Filter. It can be noticed that five poles have been reflected and they produce the same bandwidth as the lumped equivalent HN SIW Bandstop Filter.

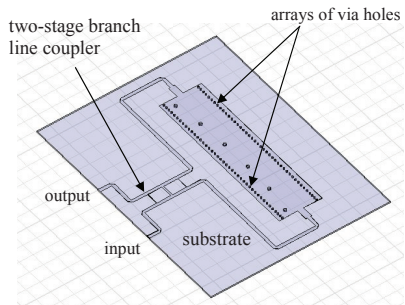

Figure 4 HN SIW Bandstop Filter

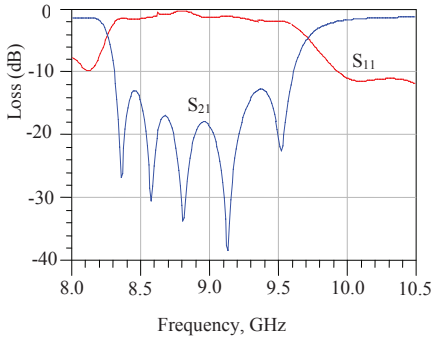

Figure 6 Simulated Frequency Response for HN SIW Bandstop Filter

IV DESIGNING AND DEVELOPING OF A PROTOTYPE HN SIW BANDSTOP FILTER

The HN SIW Bandstop Filter is manufactured using a standard PCB process with substrate of the Rogers RO 4350, with a thickness of 0.5 mm and dielectric permittivity of 3.48 and copper thickness of 35 μm . The diameter of each via hole is 0.5 mm and the distance between adjacent via holes is 1.44 mm. The structure is mounted on an aluminum block and tightened by screws to enhance the ground plane. Figure 7 shows the prototype of the HN SIW Bandstop Filter developed.

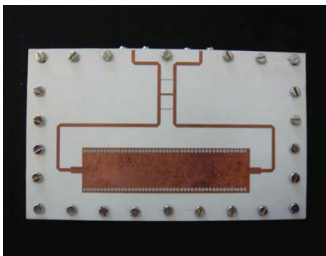

Figure 7 Prototype of the HN SIW Bandstop Filter developed.

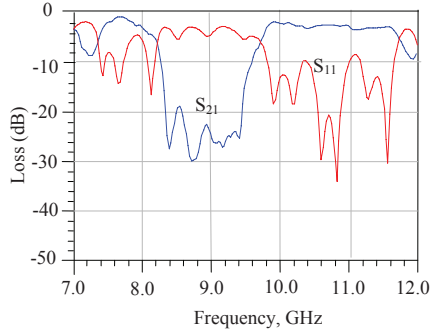

Figure 8 Frequency Response of the prototype HN SIW Bandstop Filter

Figure 8 shows the frequency response of the manufactured HN SIW Bandstop Filter taken using a vector network analyzer.

V CONCLUSIONS

This paper presents the design of a Novel Hybrid Notch SIW bandstop filter by exploiting on the much researched SIW Bandpass Filters. It can be concluded that the HN SIW bandstop filter can be developed and manufactured for microwave applications. The design is verified by simulated and measured results which reveal good outcomes and provide opportunity for further research. By maintaining the losses in the SIW bandpass filter to 1 dB, the HN SIW bandstop filter will have a reduced insertion loss of 2 dB at the pass band.

REFERENCES

- [1] D.-S. Eom, J. Byun and H.-Y. Lee, "Multilayer Substrate Integrated Waveguide Four-Way Out-of-Phase Power Divider," IEEE Transactions on Microwave Theory and Techniques, vol. 57, no. 12, pp. 3469-3476, Dec. 2009
- [2] D. Deslandes, K. Wu, "Millimeter-wave Substrate Integrated Waveguide Filters", Proceedings IEEE Electrical Computer Engineering Conference, Vol 3 pp 1917-1920 May 2003

- [3] Liu, W. Hong, Y. Zhang, J.X. Chen and K.Wu, "Half-mode substrate integrated waveguide (HMSIM) double-slot coupler", *The Institution of Engineering and Technology* 2007, *Electronic Letters*, 18 January 2007, Vol. 43, No. 2.
- [4] L. Yan, W. Hong, K. Wu. T.J. Cui, "Investigations on the Propagation Characteristics of SIW", *Proc. Int. Elect. Eng Microwave, Antenna Propagation*, Vol 52, No. 1 pp 35-42 2005
- [5] Ian C. Hunter. "Theory and Design of Microwave Filters", 2nd Edition. The Institution of Engineering and Technology, United Kingdom, 2006
- [6] Badrul Hisham Ahmad and Ian C. "Hunter Design and fabrication of a substrate integrated waveguide bandstop filter". *Proc. of the 38th European Microwave Conference*, Amsterdam. 40-42 2008
- [7] Zhang Cheng Hao, Wei Hong, Xiao Ping Chen, Ji Xen Chen, Ke Wu, Tie Jun Cui, "Multilayered Substrate Integrated Waveguide (MSIW) Elliptical Filter", *Microwave and Wireless Components Letters*, IEEE, Feb. 2005, Vol. 15, Issue 2005.
- [8] Zhang-Cheng Hao, Wei Hong, Ji-Xin Chen, Xiao-Ping Chen, Ke Wu, "Compact Super-Wide Bandpass Substrate Integrated Waveguide (SIW) Filters", *IEEE Trans. On Microwave Theory and Techniques*, Vol, 53, No. 9 2005
- [9] Chen, X., Hong, W., Cui, T., Hao, Z., Wu, K. "Substrate integrated waveguide elliptic filter with transmission line inserted inverter". *Electronic Letters*, Vol. 41, Issue 15, 851-852, 2005.
- [10] Xiaoping Chen, Wei Hong, Tiejun Chui, Jixin Chen, Ke Wu, "A Broadband Substrate Integrated Waveguide (SIW) Filter", *Antennas and Propagation Society International Symposium*, 2005 IEEE, Vol. 1B, 2005
- [11] Hunter I. C., Rhodes J. D. and Dassonville V. (1998) "Triple Mode Dielectric Resonator Hybrid Reflection Filters". *IEE Proceedings on Microwaves, Antennas and Propagation*. 145. 337-343
- [12] H. Uchimura, T. Takenoshita, M. Fujii, "Development of a Laminated Waveguide", *IEEE Trans. Microwave Theory Techniques*, Vol 46, No 12 pag 2438 - 2443, 1998.
- [13] Pilote, A.J., K.A. Leachy, B.A. Flanik, K.A. Zaki, "Waveguide filters having a layered dielectric substrate", U.A. Patent No 5382931, Jan 1995
- [14] Bray, J.R., L. Roy, "Resonant Frequencies of Post Wall Waveguide Cavities", *Proc. Inst. Elect. Eng. Vol150*, No 10, 365 – 268, Oct 2003
- [15] Han S.H., Wang X.L., Fan Y. "Analysis and Design of Multiple-Band Bandstop Filters," *Progress in Electromagnetics Research*, PIER 70, 297-306, 2007

