

# Torque Studies of 6 Slot-7 Pole Motor for Hybrid Motor

I.I.Ibrahim<sup>1</sup> and E.Sulaiman<sup>2</sup>

<sup>1</sup>*School of Mechatronic Engineering, Universiti Malaysia Perlis (UniMAP), Kampus Pauh Putra, 02600 Arau, Perlis.*

<sup>2</sup>*Universiti Tun Hussein Onn Malaysia.  
ismailshaq@unimap.edu.my*

**Abstract**—Hybrid excitation machines (HEMs) that consist of permanent magnet (PM) and field excitation coil (FEC) as their main flux sources has several attractive features compared to interior permanent magnet synchronous machines (IPMSM) conventionally employed in hybrid electric vehicles (HEVs). Hybrid excitation flux switching machines (HEFSM) is one type of HEMs. This is to decrease the PM size in a HEFSM so that the cost of the machine can be reduced. By reducing the size of PM, the torque and the power of the machine will be slightly different from the original PM size. The torque is almost the same as the original sized PM but the size is successfully reduced.

**Index Terms**—HEFSM; HEMs; HEV; Hybrid Motor.

## I. INTRODUCTION

The demand for electrical propulsion drives vehicles is getting higher to replace fossil fuel vehicles. The automotive companies in Malaysia had started to design a new type of vehicle called Hybrid Electric Vehicles (HEV) in which an electric motor is incorporated into the vehicles alongside the usage of fossil fuel engine.

Hybrid excitation flux switching machines (HEFSM) are those which utilize primary excitation by permanent magnets (PM) as well as DC field excitation coil (FEC) as a secondary source in an electric motor [1]. Permanent magnet flux switching machines (PMFSM) have relatively poor flux weakening performance but can be operated beyond base speed in the flux weakening region by means of controlling the armature winding current. By applying negative d-axis current, the PM field can be counteracted but with the disadvantage of an increase in copper loss and thereby reducing the efficiency, reduced power capability, and also possible irreversible demagnetization of the PMs. Thus, HEFSM is an alternative option where the advantages of both PM machines and DCFEC synchronous machines are combined. As such HEFSMs have the potential to improve flux weakening performance, power and torque density, variable flux capability, and efficiency which have been researched extensively over many years [2-4].

Various combinations of stator slot and rotor pole for HEFSM have been developed. For example, a 6S-4P, 6S-5P, and 6S-7P model, most of the PM flux flow into the stator iron around the FEC, while 100% flux of PM flows around the FEC for 6S-8P model. This will give advantages of less cogging torque and almost no back-emf at open-circuit condition [5,6].

## II. LITERATURE REVIEW

### A. Introduction of electric motor

An electric motor is an electrochemical device that converts electrical energy into mechanical energy [1]. Most electric motors operate through the interaction of magnetic and current-carrying conductor to generate force. Electric motors may be classified by the source of electric power, by their internal construction, by their application, or by the type of motion they give. As shown in Figure 1, the electric motor can be divided into several types which have their advantages and disadvantages [4].

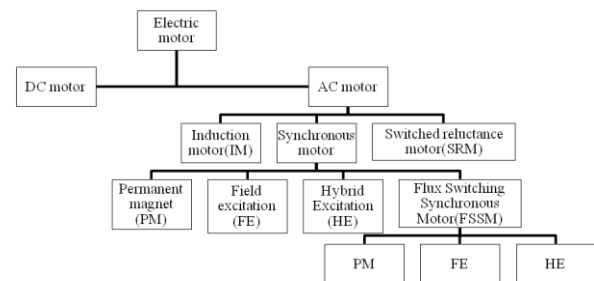

Figure 1: Electric motor types

### B. Review on Electric Motor Used in HEV

At present, the major types of electric motors under serious consideration for HEVs as well as for EVs are the dc motor, the induction motor (IM), the permanent magnet synchronous motor (SM), and the switched reluctance motor (SRM) [5]. Moreover, based on the exhaustive review on state of the art of electric-propulsion systems, it is observed that investigations on the cage IMs and the SM are highly dominant, whereas those on dc motors are decreasing but SRMs are gaining much interest [6-9]. The major requirements of HEVs electric propulsion, as mentioned in past literature, are summarized as follows:

- i. High instant power and high-power density.
- ii. High torque at low speed for starting and climbing, as well as high power at high speed for cruising.
- iii. Very wide speed range, including constant-torque and constant-power regions.
- iv. Fast torque response.
- v. High efficiency over the wide speed and torque ranges.
- vi. High efficiency for regenerative braking.
- vii. High reliability and robustness for various vehicle operating conditions.
- viii. Reasonable cost.

Moreover, by replacing the field winding with a permanent magnet (PM), the PM dc machines permit a considerable reduction in the stator diameter due to the efficient use of radial space. Since dc motor requires high maintenance mainly due to the presence of the mechanical commutator (brush), as the research advances the brushes are replaced with slippery contacts. Nevertheless, dc motor drives have a few demerits such as bulky construction, low efficiency and low reliability.

Today, an IM drive is the most mature technology among various brushless motor drives. Cage IMs are widely accepted as the most potential candidate for the electric propulsion of HEVs, due to their reliability, ruggedness, low maintenance, low cost, and ability to operate in hostile environments [6,7]. However, the presence of a breakdown torque at the critical speed, limits its extended constant-power operation. Any attempt to operate the motor at the maximum current beyond the critical speed will stall the motor. Moreover, efficiency at a high-speed range may suffer in addition to the fact that IMs efficiency is inherently lower than that of PMSM, due to the presence of rotor winding and rotor copper losses [5].

Meanwhile, SRMs are gaining much interest and are recognized to have a potential for HEV applications. These motors have definite advantages such as simple and rugged construction, low manufacturing cost, fault-tolerant operation, simple control, and outstanding torque-speed characteristics. Furthermore, SRM can inherently operate with an extremely long constant-power range. However, several disadvantages for HEV applications outweigh the advantages. They are acoustic noise generation, torque ripple, the necessity of special converter topology, excessive bus current ripple, and electromagnetic-interference (EMI) noise generation.

On the other hand, PMSMs are becoming more and more attractive and most capable of competing with other motors for the electric propulsion of HEVs. In fact, they are adopted by well-known automakers such as Toyota, Honda, etc., for their HEVs. These motors have many advantages. The overall weight and volume are significantly reduced for given output power, and it has high power density, high efficiency and high reliability. In addition, the heat generated can be efficiently dissipated to the surroundings. However, due to their limited field weakening capability, these motors are difficult to expand constant power speed region, as the presence of the fixed PM magnetic field.

The speed range may be extended three to four times over the base speed. To realize the wide speed ranges in these motors, an additional dc field excitation coil (FEC) winding is introduced, in such a way that the air-gap field provided by PMs can be weakened during a high-speed constant-power operation by controlling the direction and magnitude of the dc field current which are also called PM hybrid motors. However, at a very high-speed range, the efficiency may drop because of increase in iron loss and also there is a risk of PM demagnetization [7-9].

Another configuration of PMSM is the PM hybrid motor, where the air-gap magnetic field is obtained from the combination of PM and dc FEC as mentioned previously. In the broader term, PM hybrid motor may also include the motor whose configuration utilizes the combination of PMSM and SRM. Although the PM hybrid motor offers a wide speed range and high overall efficiency, the construction of the motor is more complex than PMSM. In other literature, the PMSM is also particularly suited for the wheel direct-

drive motor applications.

C. Classifications of Flux Switching Machine (FSM)

Generally, the FSMs can be categorized into three groups; permanent magnet flux-switching machine (PM), field excitation flux-switching machine (FE), and hybrid excitation flux-switching machine (HE). Both PM and FE has only PM and field excitation coil (FEC), respectively as their main flux sources, while HE combines both PM and FEC as their main flux sources. Figure 2 illustrates the general classification of FSMs.

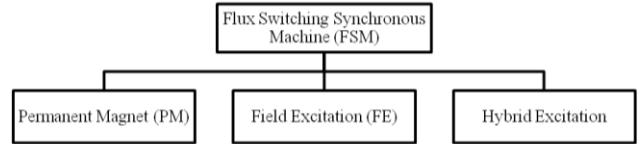

Figure 2: General classification of FSM

D. Hybrid Excitation Flux Switching Synchronous Machine (HEFSM)

Hybrid excitation flux switching machines (HEFSM) are those which utilize primary excitation by PMs as well as DC FEC as a secondary source. Conventionally, PMFSM can be operated beyond base speed in the flux weakening region by means of controlling the armature winding current. HEFSM is an alternative option where the advantages of both PM machines and DC FEC synchronous machines are combined. As such HEFSM have the potential to improve flux weakening performance, power and torque density, variable flux capability, and efficiency which have been researched extensively over many years.

The operating principle of the proposed HEFSM is illustrated in Figure 2.5, where the red and blue line indicate the flux from PM and FEC, respectively. In Figure 3(a) and (b), since the direction of both PM and FEC fluxes are in the same polarity, both fluxes are combined and move together into the rotor, hence producing more fluxes with a so-called hybrid excitation flux. Furthermore, in Figure 3(c) and (d), where the FEC is in reverse polarity, only flux of PM flows into the rotor while the flux of FEC moves around the stator outer yoke which results in less flux excitation. As one advantage of the DC FEC, the flux of PM can easily be controlled with variable flux control capabilities as well as under field weakening and or field strengthening excitation. The advantages and disadvantages of FSM discussed in this chapter are listed in Table 1.

Table 1  
Advantages and disadvantages of FSM

Advantages	Disadvantages
1. Simple and robust rotor structure suitable for high speed applications	1. Reduced copper slot area in stator
2. (Easy to manage magnet temperature rise as all active parts are located in the stator	2. Low over-load capability due to heavy saturation
3. Flux focusing / low cost ferrite magnets can also be used	3. Complicated stator
4. Sinusoidal back-emf waveform which is suitable for brushless AC operation	4. Flux leakage outside stator
	5. High magnet volume for PMFSM

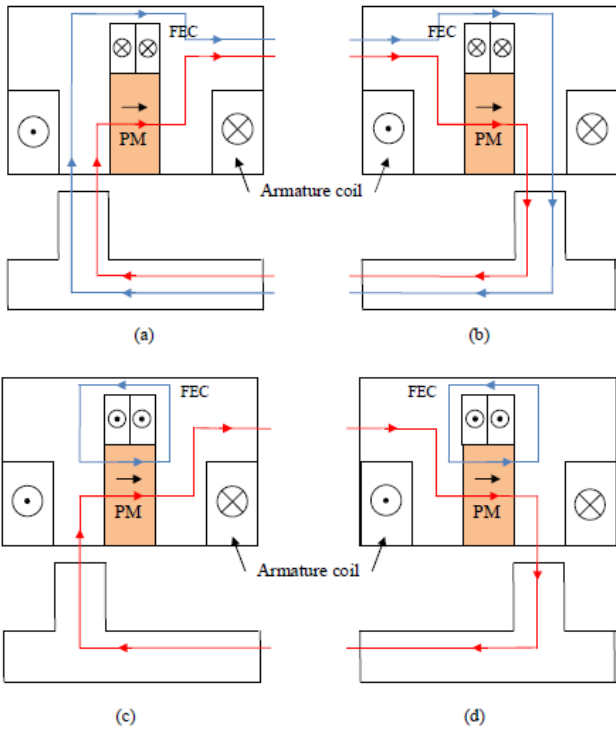

Figure 3: The operating principle of the proposed HEFSM (a)  $\theta_e=0^\circ$  - more excitation (b)  $\theta_e=180^\circ$  - more excitation (c)  $\theta_e=0^\circ$  - less excitation (d)  $\theta_e=180^\circ$  - less excitation.

### III. RESEARCH METHODOLOGY

The methodology of this research is by using JMAG-Designer version 11 software to design the motor. JMAG is simulation software for the development and design of electrical devices. JMAG was originally released in 1983 as a tool to support design for devices such as motors, actuators, circuit component, and antennas. The design of 6S-7P HEFSM is divided into two parts which are by using Geometry Editor, and it is continued by using JMAG-Designer.

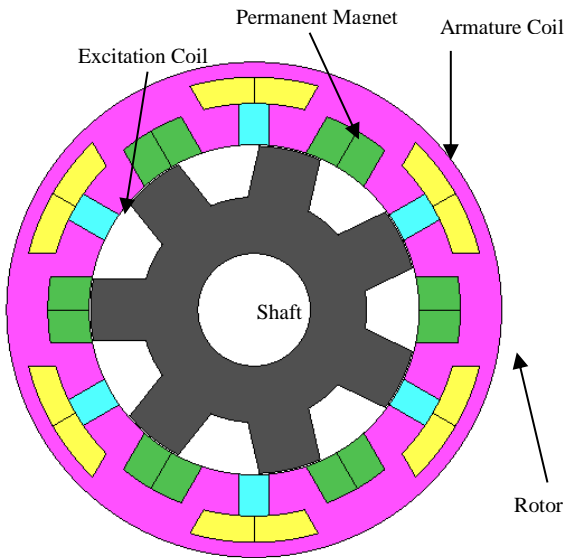

Figure 4: Design of 6S-7P HEFSM

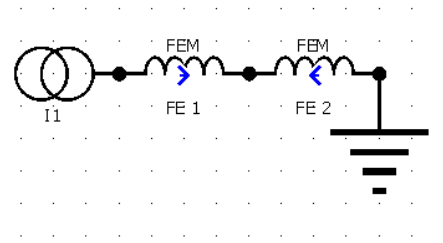

Figure 5: FEC circuit

12 armature coils of HEFSM is separated and set from Y connection to single FEM coil. The input current is neglected. The number of turn of armature coil is calculated and set by using the following equation:

$$J_A = \frac{A_{rms} N_A}{\alpha_A S_A} \quad (1)$$

- where:  $J_A$  = armature coil current density (set to maximum of 30A/mm<sup>2</sup>)
- $A_{rms}$  = Input current of armature coil (set to maximum of 30A/mm<sup>2</sup>)
- $N_A$  = no. of turn armature coil
- $\alpha_A$  = armature coil filling factor (set to 0.5)
- $S_A$  = armature coil slot area (estimate the slot area from drawing)

Thus, the number of turn of armature coil is 8 and set into the circuit.

Next, number of turn of FEC is calculated and set by using the following equation:

$$J_E = \frac{A_E N_E}{\alpha_E S_E} \quad (2)$$

- where:  $J_E$  = FEC current density (set to maximum of 30A/mm<sup>2</sup>)
- $A_E$  = Input current of FEC (set to maximum of 50A)
- $N_E$  = no. of turn of FEC
- $\alpha_E$  = FEC filling factor (set to 0.5)
- $S_E$  = FEC slot area (estimate the slot area from drawing)

Thus, the number of turns for FEC is 45 turns and set into the circuit. The analysis is run and from the flux of FEM coil results, the flux characteristic is plotted for each FEM coil of armature.

### IV. TESTING AND ANALYSIS

#### A. No-Load Analysis: UVW Coil Test

For the UVW Coil Test, the connection of the circuit and linked of the coil must be correct. Figure 6 shows the circuit connection for U, V and W. The graph for UVW fluxes is shown in Figure 7.

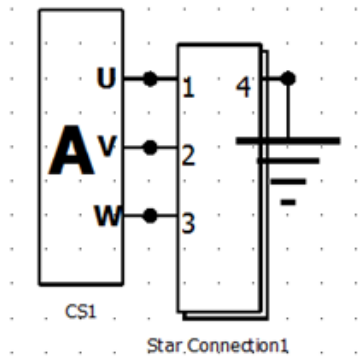

Figure 6: U, V, W connection

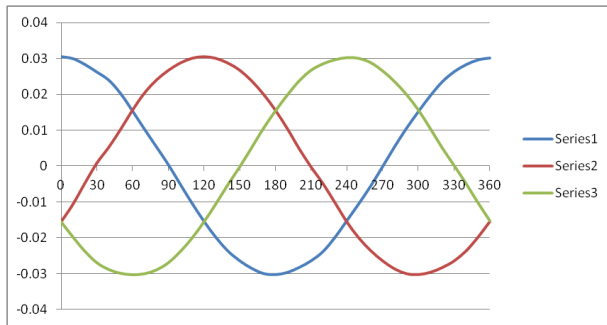

Figure 7: Graph of UVW fluxes

Figure 7 shows the correlation between the current and the phase of the UVW connections and this made up the flux reaction. This graph can show the connection of the UVW is working and the simulation runs perfectly.

### V. RESULTS AND DISCUSSIONS

After a few alterations of the PM width, the improvement of the motor is a success. The width of the motor is reduced, but the torque of the motor is almost the same as the initial PM size. The difference between the widths of the improved size and the initial size is as follows;

Table 2  
Average torque of reduced PM width

No.	Items	Average Torque
1	Initial PM width = 15.76	239.4442
2	Improved PM width = 13.76	239.0086
3	Improved PM width = 11.76	16.3031
4	Improved PM width = 9.76	14.4555

From Table 2, it is certain that the number 2 width of PM has almost the same average torque as the initial width. Thus, the number 2 width will be taken as the optimized design and the data will be compared to the initial PM width.

Figure 8 shows the UVW fluxes of the improved PM width. The maximum flux is higher than the initial PM width. The graph also shows that the UVW phases are the same as the original UVW graph as to maintain the torque value.

### VI. CONCLUSION

This study shows that the HEFSM of 6 slots-7 poles can be optimized by reducing the area of the PM. The optimized area of the PM would be the second size which has the width of 13.76mm. This optimization is crucial to reduce the cost of a HEFSM. The results show that by reducing the PM of a certain amount, the torque and the power can be maintained but by reducing the PM extensively, the HEFSM will lose its torque and power.

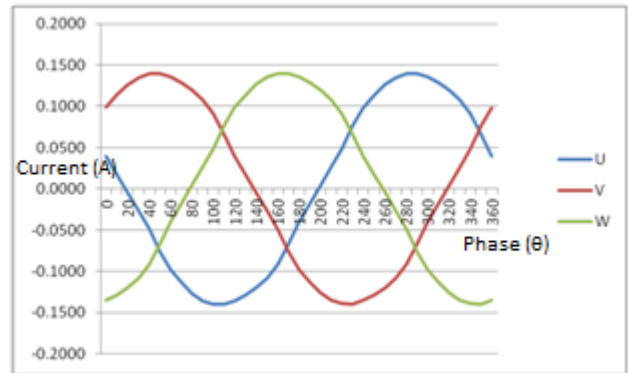

Figure 8: UVW fluxes of improved PM

### ACKNOWLEDGMENT

The authors would like to acknowledge School of Mechatronic Engineering, University Malaysia Perlis (UniMaP) and Universiti Tun Hussein Onn Malaysia (UTHM) for the opportunity to do this paper.

### REFERENCES

- [1] E. Sulaiman, M. Z. Ahmad, Z. A. Haron, and T. Kosaka, "Design studies and performance of HEFSM with various slot-pole combinations for HEV applications," *PECOn 2012 - 2012 IEEE Int. Conf. Power Energy*, no. December, pp. 424–429, 2012.
- [2] L. Vido, S. De Cachan, and R. De Gisy, "Hybrid Excitation Synchronous Machines: Energy Efficient Solutions for Vehicle Propulsion," *2006 IEEE Veh. Power Propuls. Conf.*, pp. 1–6, 2006.
- [3] C. Z. C. Zhao and Y. Y. Y. Yan, "A review of development of hybrid excitation synchronous machine," *Proc. IEEE Int. Symp. Ind. Electron. 2005. ISIE 2005.*, vol. 2, pp. 857–862, 2005.
- [4] R. L. Owen, Z. Q. Zhu, and G. W. Jewell, "Hybrid Excited Flux-Switching Permanent Magnet Machines," *IEEE Trans. Magn.*, vol. 46, no. 6, pp. 1726–1729, 2010.
- [5] Y. Liao, F. Liang, and T. A. Lipo, "A novel permanent magnet motor with doubly salient structure," *Conf. Rec. - IAS Annu. Meet. (IEEE Ind. Appl. Soc.)*, vol. 1992-Janua, no. 5, pp. 308–314, 1992.
- [6] K. T. Chau, M. Cheng, and C. C. Chan, "Nonlinear magnetic circuit analysis for a novel stator doubly fed doubly salient machine," *IEEE Trans. Magn.*, vol. 38, no. 5 I, pp. 2382–2384, 2002.
- [7] E. Sulaiman, M. Z. Ahmad, T. Kosaka, and N. Matsui, "Design optimization studies on high torque and high power density hybrid excitation flux switching motor for HEV," *Procedia Eng.*, vol. 53, no. June, pp. 312–322, 2013.
- [8] E. Sulaiman, T. Kosaka, and N. Matsui, "Design optimization of 12slot-10pole hybrid excitation flux switching synchronous machine with 0.4kg permanent magnet for hybrid electric vehicles," *8th Int. Conf. Power Electron. - ECCE Asia "Green World with Power Electron. ICPE 2011-ECCE Asia*, pp. 1913–1920, 2011.
- [9] E. Sulaiman, T. Kosaka, N. Matsui, and M. Z. Ahmad, "Design improvement and performance analysis of 12Slot-10Pole permanent magnet flux switching machine with field excitation coils," *2011 5th Int. Power Eng. Optim. Conf. PEOCO 2011 - Progr. Abstr.*, no. June, pp. 202–207, 2011.