

# Power Factor Improvement in Power System with the Integration of Renewable Energy

S.Y. Sim<sup>1</sup>, H.H. Goh<sup>1</sup>, A. J. M. S. Lim<sup>1</sup>, Y. M. Y. Buswig<sup>2</sup>, S.L. Kek<sup>1</sup>, F. Mustafa<sup>1</sup>, A. Bohari<sup>1</sup>, and M. A. Ardi<sup>1</sup>

<sup>1</sup>Universiti Tun Hussein Onn Malaysia, 86400, Parit Raja, Batu Pahat, Johor.

<sup>2</sup>Universiti Malaysia Sarawak, 94300, Kota Samarahan.

sysim@uthm.edu.my

**Abstract**—The non-linear constant increment of power demands due to loads caused a complexity in the operation of the power system network and might also cause insecurity without adequate control in the system with large power flows. A successful alternative energy source gives new challenges when connected to the power grid system. It is however that with the presence of environmental conditions, there is a constant fluctuation of generated power from renewable energy sources. This can be explained when wind power is used as a source of injection into an electric grid, where the power quality will be affected due to the fluctuating condition of the nature of the wind and comparatively new types of its generators panel. Power system control is introduced in this matter using a controller known as FACTS (Flexible AC Transmission System). FACTS controllers such as STATCOM (Static Synchronous Compensator) and SSSC (Static Synchronous Series Compensator) can function to be a terminal voltage regulator to the power system and consequently improve the systems' stability and power quality. With the usage of IEEE 14 bus power system network, both the potential STATCOM and SSSC are measured using the controller at high influential locations of the power system.

**Index Terms**—FACTS; Power Factor Improvement; Power Grid; Renewable Energy Sources.

## I. INTRODUCTION

The problems currently being faced by centralized power generation systems is the shortage of its main energy sources which is generated by fossil fuels. The electrical power losses are significantly caused by the length of the transmission lines. With that, the focus of introducing the integration of renewable energy systems to the grid will lead to massive energy efficiency and reduction of emissions. While there is a substantial increase in the penetration of renewable energy to the grid, quality in the power of the medium to low voltage in the power transmission system becomes a significant area to research on.

Power electric converters are considered to be one of the main aid in the integration of renewable energy systems to the grid. Power electronic converter is used as the main purpose to integrate the distribution in the generation to the grid power factor standards. However, high switching frequency inverter can inject additional harmonics to the system, creating major power quality problems if not carried out correctly [1, 2].

Custom Power Devices (CPD) such as Shunt Active Power Filter (STATCOM or SVC), Series Active Power Filter (SSSC or TCSC), Combination of series and shunt Active Power Filter (UPFC) are the latest development of interfacing devices between distribution supply and consumer appliances to overcome voltage/current disturbances and improves the

power quality by compensating the reactive and harmonic power generated or absorbed by the load. Natural resources from solar and wind channels to most promising distributed generation of sources while also raising their penetration level to the grid. Although the benefits of distributed generation include voltage support, diversification of power sources, reduction in transmission and distribution losses and improved reliability, power quality problems are also of growing concern [3].

Creating a hybrid Custom Power Device (CPD) is another alternative solution that fixes the issue of power quality and power stability in the power system grid especially in its power factor. The specialization of this system is that it can detect, analyzed and responded to the many perturbations from the original energy source and renewable energy source using intelligent devices, advanced control methods and digital telecommunications on electrical bus networks. This concept is the outcome of advanced technology and regulation from various stakeholders who are concerned with demand-side management and increased usage of Renewable Energy Source (RES). This system is under development and it is predicted to be a dynamic, reliable, flexible, and diverse, and it can be fully controlled. This new scenario will enable power operators to maximize the power quality, such as in Total Harmonic Distortion (THDi), Power Factor (PF), current and voltage balancing. Therefore, this will give environmental targets and will provide power systems to be more flexible in supporting plug-in distributed generation [4].

## II. POWER FLOW STUDY

The power flow study, also known as a base case, is a tool which is significantly important in applying numerical analysis in a power system. Various software applications are used to perform a variety of analysis; such examples are short-circuit fault analysis, stability studies (transient & steady-state), unit commitment and economic load dispatch analysis. Specifically, some programs use linear programming in search of optimal power flow, the conditions which give the lowest cost per kilowatt-hour delivered.

Power systems as well as finding the best operation of existing systems can be expanded in future using power flow or load-flow studies. The primary facts attained from the power flow study is the degree and phase angle of the voltage at each bus and the real and reactive power flowing in each line. Load flow studies are achieved using computer software which simulates actual steady-state power system operating conditions, enabling the evaluation of bus voltage profiles, real and reactive power flow and losses. Directing a load flow study using various scenarios helps to ensure the design of a

power system which sufficiently satisfies the performance criteria. [5].

The main reason for a power flow study is to acquire a voltage angle and magnitude information for each bus in a power system for specified load and the generator's real power and voltage conditions. Numerical methods are engaged to obtain a solution that is within an acceptable tolerance due to the nonlinear nature of this problem. A fix to the problem starts by obtaining the known and unknown variables in the system. The known and unknown variables are reliant on the type of bus. Generators that are not connected to a bus is called a Load Bus. With an exemption, a bus with at least one generator connected to it is called a Generator Bus. The exception is one arbitrarily-selected bus that has a generator. This bus is referred to as the Slack Bus [6,7]. In order to measure the influenced the STATCOM, SSSC and UPFC in controlling the grid voltage, power flow study is necessary. Furthermore, in the planning stage, flow studies are carried out to determine the assessment of ratings for STATCOM, SSSC and UPFC. Also, in a stability study, load flow solution is required to establish the initial operating point. Thus, power flow studies are indeed one of the most fundamental studies necessary to be carried out before implementing any STATCOM, SSSC and UPFC in a power system. [8].

### III. IEEE 14-BUS TEST SYSTEM

The data of test system applied in this study is from IEEE 14-bus test system. The single line diagram of the 14-bus test system is shown in Figure 1.

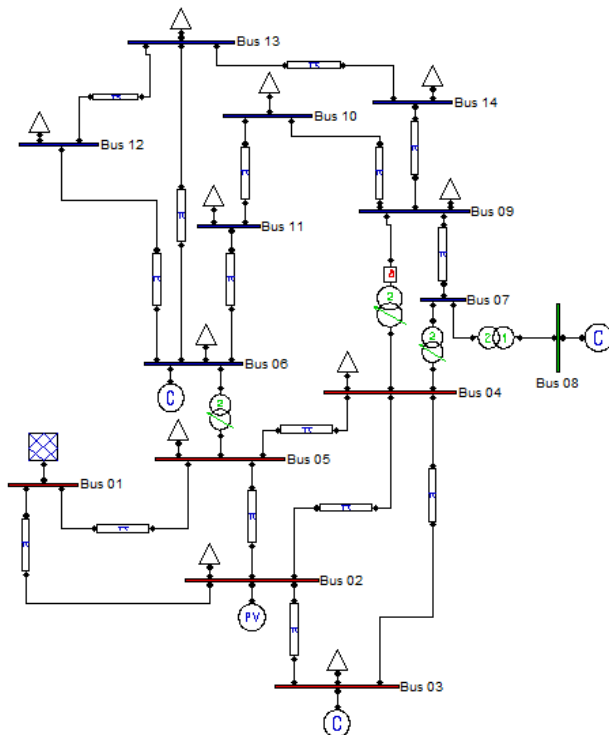

Figure 1: IEEE 14-bus test system [9, 10].

The MATLAB/PSAT software is used to apply, test and analyse data sampling. From the application of the simulation software, the data sampling will be obtained from the IEEE standard bus system, The IEEE 14-bus test system was studied using the PSAT programs to obtain the system P-V curves and perform time domain and eigenvalue analyses to study the general performance of the system [9, 10].

The FACTS controllers were placed on location in such a way that the capability of FACTS controllers to compensate a particular bus or line could be optimized. Therefore, it is best if the FACTS controllers would be located shunt with the weakest bus (in the case of shunt connected FACTS controllers) or series with a line that has the lowest percentage of underutilized capacity or higher power losses in the selected voltage magnitude profile (in the case of series connected FACTS controllers).

Consequently, in order to govern the weakest bus and the underutilized line in the test system, power flow analysis was applied. The test system was analyzed without the FACTS controllers and hence the original performance of the test system was required. Voltage magnitude profiles (bus voltage in per unit versus the increasing loading parameter) for all the buses in the test network were plotted and the bus in which collapses the worst among other buses has been selected as the weak bus. Alternatively, relying on the power flow report, the most underutilized line or higher power losses in the selected voltage magnitude profile were determined. The line in which has the lowest power flow out of its total rating was selected as the line that needs series compensation [11].

Subsequently, the location of the FACTS controllers' is determined, the FACTS controllers were inserted in the tested network. The series FACTS controllers, SSSC were placed in series with the selected line. The shunt FACTS controllers, STATCOM would be placed in parallel with the selected bus. Based on the lowest voltage magnitude, then following by underutilized line or higher power losses in the selected voltage magnitude profile determined earlier, the shunt-series on the line is used. The series part of compensator connected in series with the line and shunt part of compensator shunted with the bus. The compensator would be placed in the middle of the line, resulted in the line impedance divided into two. The series shunt FACTS controllers, UPFC will be implemented. The performance of each FACTS controller will be compared. A power flow would be used for the process of evaluating the performance of FACTS controllers. Voltage profile for every bus and the power flow for each line will be acquired.

The power flow was first used on the test system without the deliberation of FACTS controllers (base case) to obtain the performance of the system without any compensator, and hence attained the location for FACTS controllers' placement. The application of power flow in the system yielding the voltage magnitude profile of each bus and also the power flow report that was used in the determination of location for FACTS controllers. Shunt controllers were placed at the bus in which has the worst voltage profile. While series FACTS controllers on the other hand, were placed in series with the line that has the uppermost percentage of underutilized capacity or higher power losses in the selected voltage magnitude profile. Note that the FACTS controllers were implanted one at a time to ensure the performance of each FACTS controller could be observed and analyzed. [12].

### IV. RESULT AND ANALYSIS

The IEEE 14-Bus Test System as shown in Figure 1 consists of 14 buses and 11 loads. The total generation and load for the system are 392.03 MVA and 204.24 MVA respectively. Voltage magnitude profiles as shown in Figure 2 and power flow result as shown in Figure 3 were plotted to determine the weakest bus for the base case system.

As depicted in Figure 3, there have two buses that the voltage magnitude below 1p.u. The lowest voltage magnitude is 0.99659p.u which is bus 14, following by bus 4 with 0.99782p.u. After some comparisons, it was obtained that bus number 14 and 4 severely collapsed due to the increasing load. With this, bus 14 and bus 4 was selected to be the location of FACTS controllers' placement. Three testing method will be used to analyze the result. The method is explained as below:

- i. Testing method 1 (green label and yellow label):  
Inject STATCOM at bus 14 and SSSC at bus 4.
- ii. Testing method 2 (green label only):  
Inject STATCOM and SSSC at bus 14.
- iii. Testing method 3 (green label only)  
Inject UPFC at bus 14.

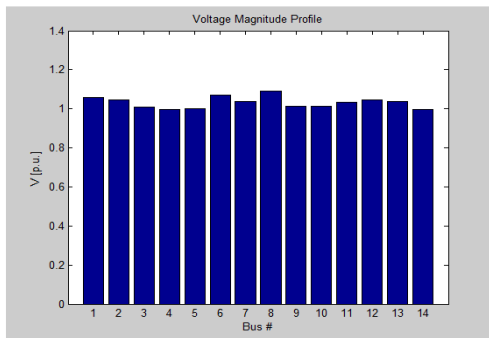

Figure 2: Voltage magnitude profile for base case.

POWER FLOW RESULTS

Bus	V [p.u.]	phase [rad]	P gen [p.u.]	Q gen [p.u.]	P load [p.u.]	Q load [p.u.]
Bus 01	1.06	0	3.5203	-0.28197	0	0
Bus 02	1.045	-0.13568	0.4	0.9486	0.3038	0.1778
Bus 03	1.01	-0.33212	0	0.59736	1.3188	0.266
Bus 04	0.99782	-0.26441	0	0	0.6692	0.056
Bus 05	1.0029	-0.22695	0	0	0.1064	0.0224
Bus 06	1.07	-0.36956	0	0.44433	0.1568	0.105
Bus 07	1.036	-0.33938	0	0	0	0
Bus 08	1.09	-0.33938	0	0.33402	0	0
Bus 09	1.0129	-0.37908	0	0	0.413	0.2324
Bus 10	1.0122	-0.38446	0	0	0.126	0.0812
Bus 11	1.0357	-0.37984	0	0	0.049	0.0252
Bus 12	1.0462	-0.39059	0	0	0.0854	0.0224
Bus 13	1.0366	-0.39147	0	0	0.189	0.0812
Bus 14	0.99695	-0.41056	0	0	0.2086	0.07

Figure 3: Power flow results

A. Simulation of Wind Integration System with STATCOM and SSSC Using Testing Method 1.

The weakest bus in the system was at bus 4 and bus 14. Therefore, STATCOM will be placed at bus 14, while SSSC will be placed at bus 4, to simulate the effect and the performance of shunt and series FACTS controllers to the system. The Simulink models were simulated using the power flow method. The voltage magnitude profile was shown in Figures 4 for the wind integration system with and without

STATCOM and SSSC using testing method 1. From the graph, we can see the voltage magnitude was improved after injected with FACTS controllers. Figure 5 shows the details about the power flow results for voltage magnitude profile. It is clearly shown that the voltage magnitude for bus 14 increased from 0.99695p.u to 1.045p.u and bus 4 increased from 0.99782p.u to 1.0185p.u.

B. Simulation of Wind Integration System with STATCOM and SSSC Using Testing Method 2.

In this case, STATCOM and SSSC will be placed at bus 14, to simulate the effect and the performance of FACTS controllers to the system. The voltage magnitude profiles for the wind integration system with and without STATCOM and SSSC using testing method 2 is shown in Figure 6. The details on power flow results for voltage magnitude profile is shown in Figure 7. One can observe that the voltage magnitude for bus 14 increased from 0.99695p.u from base case to 1.045p.u.

C. Simulation of Wind Integration System with UPFC Using Testing Method 3.

In this case, UPFC will be placed at bus 14, to simulate the effect and the performance of FACTS controllers to the system. The voltage magnitude profiles for the wind integration system with and without UPFC using testing method 3 is shown in Figure 8. The details on power flow results for voltage magnitude profile is shown in Figure 9. It is show that the voltage magnitude for bus 14 increased from 0.99695p.u to 1.045p.u.

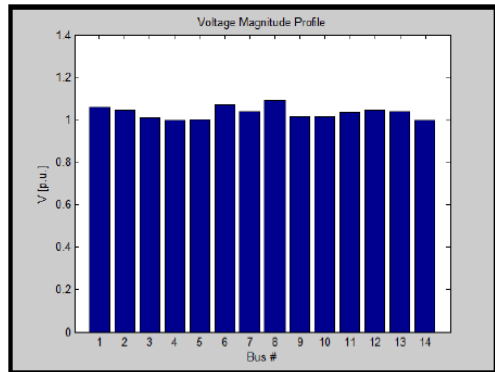

(a) Without FACTS Controllers

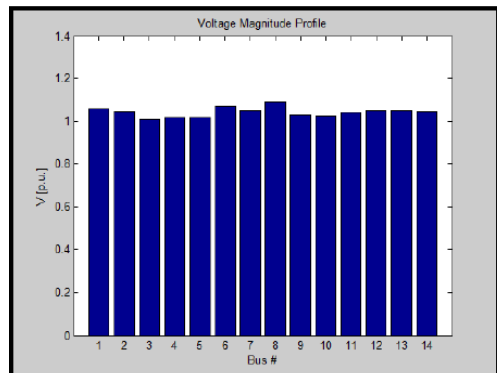

(b) With FACTS Controllers

Figure 4: Voltage magnitude profile after injected with FACTS Controllers using testing method 1.

POWER FLOW RESULTS

Bus	V [p.u.]	phase [rad]	P gen [p.u.]	Q gen [p.u.]	P load [p.u.]	Q load [p.u.]
Bus 01	1.06	0	3.0184	-0.2928	0	0
Bus 02	1.045	-0.11846	0.4	0.96418	0.3038	0.1778
Bus 03	1.01	-0.29363	0	0.47486	1.3188	0.266
Bus 04	<b>1.0185</b>	<b>-0.21556</b>	<b>0</b>	<b>0</b>	<b>0.6692</b>	<b>0.056</b>
Bus 05	1.0191	-0.18438	0	0	0.1064	0.0224
Bus 06	1.07	-0.28257	0	0.28907	0.1568	0.105
Bus 07	1.0488	-0.26199	0	0	0	0
Bus 08	1.09	-0.26199	0	0.2549	0	0
Bus 09	1.0279	-0.28672	0	0	0.413	0.2324
Bus 10	1.0248	-0.29305	0	0	0.126	0.0812
Bus 11	1.0422	-0.29076	0	0	0.049	0.0252
Bus 12	1.0506	-0.29564	0	0	0.0854	0.0224
Bus 13	1.0485	-0.2903	0	0	0.189	0.0812
Bus 14	<b>1.045</b>	<b>-0.25911</b>	<b>0.4</b>	<b>0.037</b>	<b>0.2086</b>	<b>0.07</b>

Figure 5: Power flow results by using testing method 1

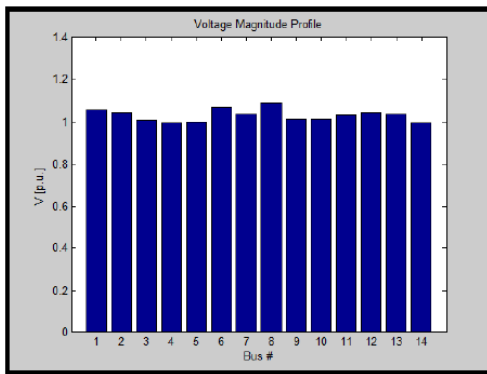

(a) Without FACTS Controllers

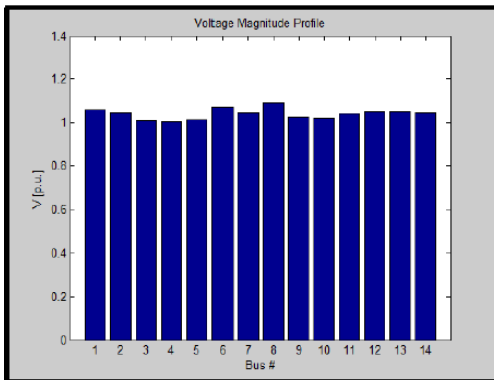

(b) With FACTS Controllers

Figure 6: Voltage magnitude profile after injected with FACTS Controllers using testing method 2.

POWER FLOW RESULTS

Bus	V [p.u.]	phase [rad]	P gen [p.u.]	Q gen [p.u.]	P load [p.u.]	Q load [p.u.]
Bus 01	1.06	0	3.0511	-0.25775	0	0
Bus 02	1.045	-0.11802	0.4	0.76476	0.3038	0.1778
Bus 03	1.01	-0.30242	0	0.54577	1.3188	0.266
Bus 04	1.0065	-0.2274	0	0	0.6692	0.056
Bus 05	1.0115	-0.19263	0	0	0.1064	0.0224
Bus 06	1.07	-0.29107	0	0.30522	0.1568	0.105
Bus 07	1.044	-0.27472	0	0	0	0
Bus 08	1.09	-0.27472	0	0.28489	0	0
Bus 09	1.0239	-0.29973	0	0	0.413	0.2324
Bus 10	1.0214	-0.30526	0	0	0.126	0.0812
Bus 11	1.0404	-0.30109	0	0	0.049	0.0252
Bus 12	1.052	-0.30377	0	0	0.0854	0.0224
Bus 13	1.0514	-0.29862	0	0	0.189	0.0812
Bus 14	<b>1.045</b>	<b>-0.27767</b>	<b>0.4</b>	<b>0.07906</b>	<b>0.2086</b>	<b>0.07</b>

Figure 7: Power flow results by using testing method 2.

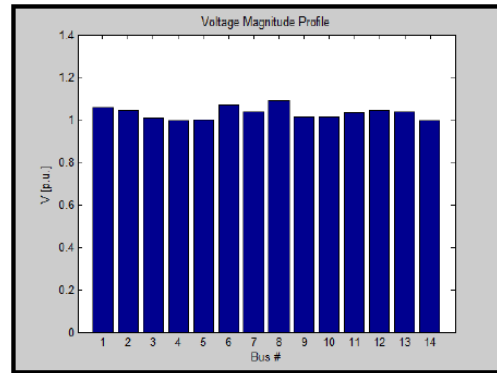

(a) Without FACTS Controllers

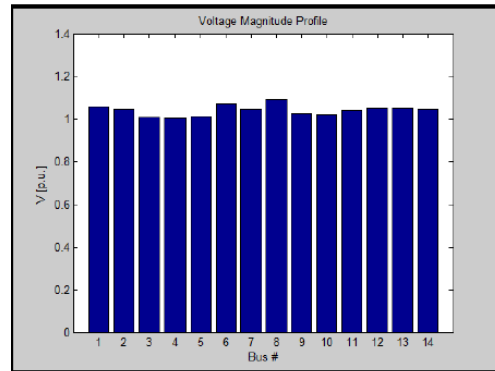

(b) With FACTS Controllers

Figure 8 Voltage magnitude profile after injected with FACTS Controllers using testing method 3.

## POWER FLOW RESULTS

Bus	V [p.u.]	phase [rad]	P gen [p.u.]	Q gen [p.u.]	P load [p.u.]	Q load [p.u.]
Bus 01	1.06	0	3.0511	-0.25775	0	0
Bus 02	1.045	-0.11802	0.4	0.76476	0.3038	0.1778
Bus 03	1.01	-0.30242	0	0.54577	1.3188	0.266
Bus 04	1.0065	-0.2274	0	0	0.6692	0.056
Bus 05	1.0115	-0.19263	0	0	0.1064	0.0224
Bus 06	1.07	-0.29107	0	0.30522	0.1568	0.105
Bus 07	1.044	-0.27472	0	0	0	0
Bus 08	1.09	-0.27472	0	0.28489	0	0
Bus 09	1.0239	-0.29973	0	0	0.413	0.2324
Bus 10	1.0214	-0.30526	0	0	0.126	0.0812
Bus 11	1.0404	-0.30109	0	0	0.049	0.0252
Bus 12	1.052	-0.30377	0	0	0.0854	0.0224
Bus 13	1.0514	-0.29862	0	0	0.189	0.0812
Bus 14	1.045	-0.27767	0.4	0.07906	0.2086	0.07

Figure 9: Power flow results by using testing method 3

Table 1  
Simulation Results for the testing.

Sample Method	Bus/Line			Power Factor	P Losses [p.u]
	SSSC	STATCOM	UPFC		
0	-	-	-	0.89	0.2943
1	2-4	14	-	0.91	0.19243
2	14-13	14	-	0.91	0.22513
3	-	-	14-13	0.91	0.22513

The overall simulation results I showed in Table 1. The power factor for base case is 0.89, while the real power losses are 0.2943p.u. For the method 1, SSSC is applied in line 2-4 and STATCOM is applied at bus 14. The power factor for method 1 is 0.91 and the real power losses are 0.19243p.u. For method 2, SSSC is applied in line 14-13, while STATCOM is applied at bus 14. The power factor for method 2 is same as the power factor in method 1, which is 0.91. But the real power losses for method 2 are slightly higher than method 1, which is 0.22513p.u. That made the method 2 transferred less power than method 1. For method 3, we use UPFC as FACTS controllers. It used to prove that their effect will be the same with SSSC and STATCOM which is in method 2. It is because UPFC is a combination of shunt-series compensator that is SSSC and STATCOM. The UPFC is applied in line 14-13. From the table, we can see the power factor and real power losses for method 3 are 0.91 and 0.22513p.u, same with the method 2. From the results, we can conclude that the best method is method 1, which is obtained 0.91 for power factor and 0.19243p.u for real power losses. That meant method 1 transferred more power to the system than the other method. Therefore the power losses are less than the other method.

## V. CONCLUSION

The purpose of this study is to identify the effect of hybrid FACTS controllers in term of power factor and power quality

improvement when implementing it in power system. The performance of each FACTS controllers used has been evaluated. The FACTS controllers' locations are tested at a different location and found that location of FACTS controllers gives different amount of losses and power factor improvement. Therefore, it could be concluded that specific type of FACTS controllers would improve some of the power system parameters, by depend also on the injected locations. This study has successfully tested at the 14-bus test system and optimal location of STATCOM, SSSC and UPFC also had been determined by refer to the voltage magnitude and power losses. The performance of the power system with different location of the device also had been analyzed and found that SSSC and STATCOM give better effect to the performance of the system than UPFC. As a conclusion, the power factor and power losses can be improved by employing hybrid FACTS controllers at the rights locations.

## ACKNOWLEDGEMENT

The authors would like to acknowledge the Universiti Tun Hussein Onn Malaysia (UTHM) and the Ministry of Higher Education (MOHE) for the financial support for this study under the research grant FRGS VOT. 1561.

## REFERENCES

- [1] S. K. Khadem, M. Basu and M.F. Conlon. "Power Quality in Grid connected Renewable Energy Systems: Role of Custom Power Devices," *ICREPO*, 2010.
- [2] K. Kumar, S. S. Mathew. Conlon." Power Quality Improvement through Pitch Angle Control of Variable Speed Wind Turbines," *International Journal of Advanced Research in Electrical, Electronics and Instrumentation Engineering*, vol. 3, pp. 10353-10358, June 2014.
- [3] I. El-Samahy, El-Saadany. "The Effect of DG on Power Quality in a Deregulated Environment", *IEEE Power Engineering Society General Meeting*, pp. 2969-2976, 2005.
- [4] N. A. Hidayatullah, "Impacts of Distributed Generation on Smart Grid," *Victorial University, Master's Thesis*, 2011.
- [5] M.F. Daud, "Testing of Statcom Model In Ieee Power System Network Using Pscad Software," *Universiti Malaysia Pahang*, 2008.
- [6] A. Pateriya, N.Saxena and M.Tiwari. "Transfer Capability Enhancement of Transmission Line using Static Synchronous Compensator (STATCOM)", *International Journal of Advanced Computer Research*, vol. 2, no 4, pp. 83-88, December 2012.
- [7] J. P. Navani, N. K. Sharma, and Sapra. "Technical and non-technical losses in power system and its economic consequence in Indian economy." *International Journal of Electronics and Computer Science Engineering*, pp. 757-761, 2012.
- [8] A. Bhargava, V. Pant and B. Das, "An Improved Power Flow Analysis Technique with STATCOM," *International Conference on Power Electronic, Drives and Energy Systems*, New Delhi, 2006, pp. 1-5.
- [9] S. K. M. Kods, "Modeling and Simulation of IEEE 14 bus System with FACTS Controllers", *University of Waterloo, Canada, Tech. Rep.*, 2003.
- [10] P.K. Iyambo, and R. Tzoneva.. "Transient Stability Analysis of the IEEE 14-Bus Electric Power System," *AFRICON IEEE*, 2007.
- [11] L.A.S. Pilotto, W.F. Long and A. Edris. "Determination of Needed FACTS Controllers That Increase Asset Utilization of Power Systems," *IEEE Transactions on Power Delivery*, vol. 12, No 1, pp. 364-371 January 1997.
- [12] M. Waqar, N. Khan, M. adnan, W. Khalid, and M. R. Fazal, "Transient Stability Improvisation in Power System by Utilizing the Concepts of UPFC, STATCOM and SSSC," *International Journal of Scientific & Engineering Research*, vol 7, pp. 841-869, October 2016.