

Modelling of a Cable-driven Ankle Rehabilitation Robot

Mohd Nazrin Shahrol¹, Shafriza Nisha Basah¹, Khairul Salleh Basaruddin¹, Wan Khairunizam Wan Ahmad¹
Shahrol Aman Ahmad²

¹*School of Mechatronic, Universiti Malaysia Perlis (UniMAP), Pauh Putra Campus, 02600, Arau, Perlis, MALAYSIA*

²*College of Arts and Sciences (UUMCAS), Universiti Utara Malaysia, 06010 Sintok, Kedah, MALAYSIA*
nazrinshahrol@gmail.com

Abstract—Ankle injury is one of physical injury that commonly occurs in sports or domestic-related activities. Presently, there are various established treatments for ankle rehabilitation in hospital or rehabilitation clinic. This involves a range of motion treatment exercise and endurance treatment exercise. However, current treatment requires patients to frequently visit to the hospital which is tedious and also repetitive. One of the solutions to deal with the repetitiveness of the treatment is to introduce an automated device such as a robot that can help the therapist to perform this repetitive task on the patients. A concept design for a cable driven ankle rehabilitation robot has been proposed for this task. The reason for selecting cable-based design is the design is lighter than a rigidly based robot. This adds up its potential for mobility and portability which allows convenience to the users. The focus of this paper is to present inverse kinematics analysis and modelling of the proposed concept design of the robot which aimed to determine the feasibility of the concept design. Overall, the modelling of the cable-based ankle rehabilitation robot using inverse kinematics is feasible to project or to predict the trajectory paths of the moving platform of the robot. This will be useful for planning suitable dimension for fabrication of the robot.

Index Terms—Cable Driven Robot; Ankle Injury; Inverse Kinematics; Modelling.

I. INTRODUCTION

The ankle joint is one of the most important joints for human because it helps to maintain body balance during movement [1]. However, the ankle has a tendency to be injured if its movement is excessive. Evident showed ankle injury is one of the most common sports injuries [2]. Also, domestic-related accidents can contribute to some cases of ankle injuries [3].

To deal with an ankle injury, hospitals and rehabilitation clinics had provided several of ankle rehabilitation treatments that are handled by a professional therapist. These treatments can help to ensure adequate recovery of ankle injury instead of self-recovering the injury [2]. However, the available treatments were tedious, and these were heavily restricted at the hospital [4]. This prevents the treatment from being performed at home. Home rehabilitation is essential as it can potentially help to increase the frequency of the treatment.

One of the solutions to this problem is to introduce a portable ankle rehabilitation robot where a robot can be quickly set up at home. Also, it must be easy to configure according to several ankle rehabilitation exercises. A concept design for the robot has been produced which is based on parallel mechanism and cables. A parallel robot has a good

payload-to-weight ratio which reduces wear and tear of the manipulator as the load is shared by every actuator that is driving the end effector [5]. The concept design has been generated and selected through design tools such as Morphological Chart and Pugh Method [6]. The parameters considered were based on qualitative features such as the ability to configure and portability. These features are important as it can give patients an ability to conduct rehabilitation at home.

However, using qualitative evaluation alone is insufficient to present the design feasibility fully. This is because some of the comprehensive evaluation of the design requires values or numbers to determine whether the design is practical or not especially when involving concept designs that are similar to each other. Therefore, additional design evaluation such as quantitative evaluation is needed.

In this paper, Inverse Kinematics or IK is one of the analyses that is used to evaluate the feasibility of the robot regarding quantitative design evaluation. The purpose of IK calculation is to define the trajectory of the robot's end effector, in this case, the moving platform is represented as the end effector of the robot. This is important as the designers need to know the final trajectory of the end effector would be if the particular initial movement from the actuators or robotic joints is applied. This prevents major redesigning of the robot after fabrication is implemented and also prevents avoidable time taken to do the redesigning. By achieving this analysis, the concept design can be moved forward towards the fabrication of the proposed ankle rehabilitation robot.

II. ROTATION ANGLE FOR EVERY MOVEMENT OF THE ANKLE

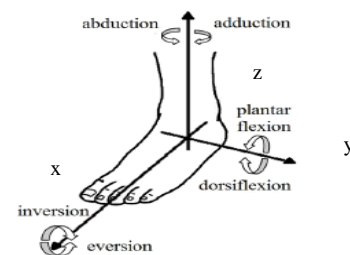

Figure 1: Type of basic ankle rotation on the xyz – axis [7].

The calculation of IK for ankle movement will be referred from the data provided in Table 1. The reason for this selection is the ankle movement is usually categorised by presenting its movement under Cartesian coordinate [7, 8].

The ankle rotates around the three axes of the coordinate of x, y and z which are represented in Figure 1. The ankle is fixed with Cartesian coordinate and axes x, y and z represent rotating pivot under three different directions in which it can be represented as three different rotating movements under three axes (x, y and z). The ranges of each primary ankle motion described are listed in Table.1 below according to Saglia [3].

Table 1
The range of angle for ankle motion with basic ankle motions [3].

Axes	Name of the Motion	Range of Motion
X	Inversion	14.5° - 22°
	Eversion	10° - 17°
Y	Dorsiflexion	20° - 30°
	Plantar flexion	37° - 45°
Z	Adduction	22° - 35°
	Abduction	15° - 25°

III. CABLE DRIVE MODELLING USING INVERSE KINEMATICS

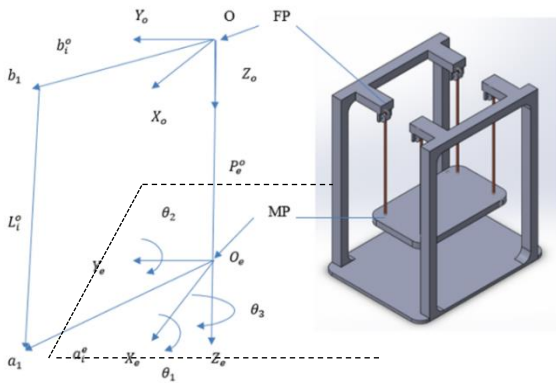

Figure 2: Line sketch of a pulley and its position vectors on FP and MP with its 3D Model representation

In robotics explicitly for the parallel robot, IK calculation is used to obtain the coordinate of the end effector based on rotation angle of the joints. Figure 2 shows the position vectors of the cables with its 3D Model representation. The position vectors are divided into the fixed platform (FP) and moving platform (MP). A patient will place and strapped their foot on the MP, and the MP will be driven through the cables by the actuators that are located from above. The connection points on the moving platform are denoted by a's while connection points on the fixed platform are denoted by b's. All of the connection points on FP are located on the same plane which represents $Z_o = 0$. These connection points are also positioned at the radial distance of r^b from the origin which is represented as O.

θ_1, θ_2 and θ_3 are represented by the angular rotation in the x-axis, y-axis and z-axis respectively. The value 'i' from Figure 2 is representing the position of the connecting points for both FP, and MP. Figure 3 shows the position of the connection points between FP and MP and the position of the angle α and β . α_i is represented the angular position of point a_i on the moving platform while β_i is an angular position of the connection point b_i on FP. Both angles are referred with respect to their respective axes.

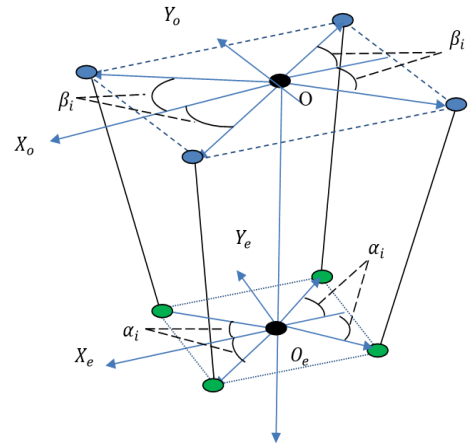

Figure 3: Positions of connection points of Fixed Platform (Blue) and position of connection points Moving Platform (Green) with respective to O and O_e

$$b_i^o = \begin{bmatrix} r_i^b \cos \beta_i \\ r_i^b \sin \beta_i \\ 0 \end{bmatrix} \quad (1)$$

In Equation (1), r_i^b represents the radial distance of fixed connection point from the fixed coordinate frame O.

$$a_i^e = \begin{bmatrix} r_i^a \cos \alpha_i \\ r_i^a \sin \alpha_i \\ -K \end{bmatrix} \quad (2)$$

K in Equation (2) represents the distance of between position of the ankle joint and the position above moving plate level. In this case, the value of K will be 60mm which is based on estimate length between ankle joint and the moving platform from the previous research works [8]. Also, the position vector r_i^a represents the radial distance of the fixed connecting point from the fixed coordinate frame O_e .

$$L_i^o = P_e^o + R_e^o a_i^e - b_i^o \quad (3)$$

$$|L_i^o| = \sqrt{u_x^2 + u_y^2 + u_z^2} \quad (4)$$

The position of the actuator lengths for each connecting point is shown in Equation (3). Equation (4) shows how to obtain the length of the cable based on the position vectors of L_i^o . u_x, u_y and u_z are representing the connecting points of a_i . P_e^o shows the position vector of point O_e with respect to O. R_e^o represent the rotational transformation matrix of the moving platform concerning FP using a fixed axis rotation sequence with (W_o, Y_o, Z_o) in Equation (5) based on multiplication of all rotation in every axis:

$$\begin{aligned}
 R_E^O &= R_Z(\theta_3)R_Y(\theta_2)R_X(\theta_1) \\
 R_E^O &= \begin{bmatrix} C\theta_3 & S\theta_3 & 0 \\ -S\theta_3 & C\theta_3 & 0 \\ 0 & 0 & 1 \end{bmatrix} \begin{bmatrix} C\theta_2 & 0 & -S\theta_2 \\ 0 & 1 & 0 \\ S\theta_2 & 0 & C\theta_2 \end{bmatrix} \begin{bmatrix} 1 & 0 & 0 \\ 0 & C\theta_1 & S\theta_1 \\ 0 & -S\theta_1 & C\theta_1 \end{bmatrix} \\
 R_E^O &= \begin{bmatrix} C\theta_3 & S\theta_3 & 0 \\ -S\theta_3 & C\theta_3 & 0 \\ 0 & 0 & 1 \end{bmatrix} \begin{bmatrix} C\theta_2 & S\theta_1 S\theta_2 & -C\theta_1 S\theta_2 \\ 0 & C\theta_1 & S\theta_1 \\ S\theta_2 & -S\theta_1 C\theta_2 & C\theta_1 C\theta_2 \end{bmatrix} \\
 R_E^O &= \begin{bmatrix} C\theta_3 C\theta_2 & C\theta_3 S\theta_2 S\theta_1 + S\theta_3 C\theta_1 & S\theta_3 S\theta_1 - C\theta_3 S\theta_2 C\theta_1 \\ -S\theta_3 C\theta_2 & C\theta_3 C\theta_1 - S\theta_3 S\theta_2 S\theta_1 & S\theta_3 S\theta_2 C\theta_1 + C\theta_3 S\theta_1 \\ S\theta_2 & -C\theta_2 S\theta_1 & C\theta_1 C\theta_2 \end{bmatrix} \\
 ; S\theta &= \sin \theta, C\theta = \cos \theta
 \end{aligned} \quad (5)$$

However, the equations need to be combined with an additional geometrical calculation to obtain the right coordination for the new connection point. This is because rotational transformation matrix only rotates according to the point of origin O_e not to the rotation of x-Axis line, y-Axis line and z-Axis line.

IV. GEOMETRIC CALCULATION FOR INVERSE KINEMATICS

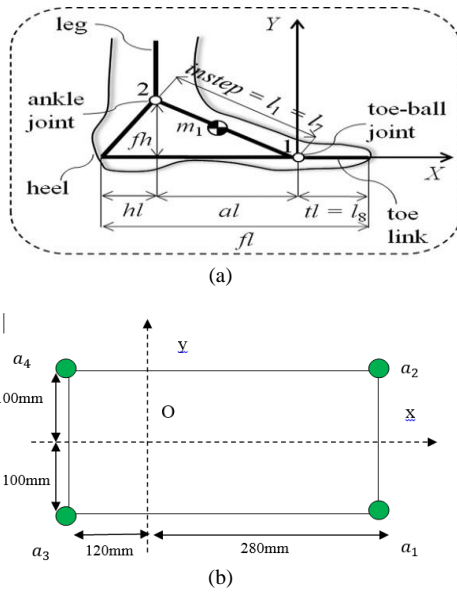

Figure 4: The estimated position of the ankle joint with ratio of 7:3 which represented $(al+tl):hl$. al is an arc length, tl is a toe length, and hl is a heel length. (a). The line sketch of the platform with the position of the origin as a reference point for moving platform rotation. (b). The green points are representing the connecting points of the moving platform.

As the centre of rotation of the ankle was not perpendicular to the centre of the moving platform. The calculation must be referred according to the position of the ankle joint. Thus, the centre of rotation of the moving platform was determined based on a study conducted by Mummolo et al. [9]. Based on the study, the position of the ankle joint is positioned based on the ratio of 7:3. 3 was represented by the length of heel and 7 is a combination of arc length and toe length. This ratio then was used to derive the actual position of the origin O for the moving platform. Figure 4 includes the line sketch of the moving platform alongside with multisegmental foot models. Also, the ideal length for the moving platform is fixed at 400x200 (mm) based on the previous robot design [10]. However, selecting the number of cables are important as if too much cable is installed, it will add up unnecessary additional motion than needed to the robot and also adds up

unnecessary weight to the robot. If less cable is installed than needed, the robot will have difficulty to achieve basic movement of the ankle needs to perform the ankle exercise.

A. Selecting A Number of Cables into The Calculation

The Equation (6) is used to determine the degree of freedom for the robot and to select whether the degree of freedom or DOF is appropriate for ankle rehabilitation robot. Ideally, an ideal ankle rehabilitation robot needs at least 3 DOF to fulfil the movement of the ankle if basic ankle movements which are represented in 3 DOF. If the moving cables (links) is less than 3, the DOF for ankle rehabilitation is insufficient to be compatible with the movement of the ankle. While involving more than 3 moving cables will require additional actuators which increase the unwanted weight of the robot. Nevertheless, 4 Moving Cables is selected in this investigation to determine whether additional cable can make a significant difference in trajectory with 3 Moving Cables.

$$F = \lambda(n - j - 1) + \sum_{i=1}^j f_i - f_p \quad (6)$$

where:

F is total number degree of freedom of the system

λ is a degree of freedom of space ($\lambda=6$ for the spatial mechanism, $\lambda=3$ for planar mechanism)

n is the number of rigid links (including fixed base) in the mechanism

j is the number of binary joints (active and passive joints) in the mechanism

f_i is number of degrees of freedom connected with the i^{th} joint.

f_p is the total number of passive joints degree of freedom

For example:

If 3 Cables attached to moving platform is chosen; then $\lambda=6$ (Spatial mechanism), $n=4$, $j=3$, $f_i=3$ and $f_p=0$

$F = 6(4 - 3 - 1) + \sum_{i=3}^j 1 - 0 = 3$, so its DOF will be 3.

B. For Rotation of θ_1 (x-axis)

For rotation of θ_1 (x-axis), the ankle rehabilitation exercises that are involved are Assisted Circle Stretches, Range of Motion and Balancing.

Figure 5 shows the position connecting points (green dots) and the reference points of M and N (red dots which are located on the y-axis line. For Equation (7) and Equation (9), the reference point of M and N will be rotated under x-axis presented as a new coordinate of M_2 and N_2 . The addition of 280mm and the reduction of 120mm to M_2 and N_2 in Equation (8) and Equation (10) is used to obtain the final coordinate of the connecting points of a_1, a_2, a_3 and a_4 (4 Moving Cables) and a_3 and a_4 (3 Moving Cables).

The reason for presenting this calculation is the rotational transformation matrix can only be used to calculate the position of the connecting points based on origin 'O' and not based on the x-axis as intended in the literature (Liu). However, these are exceptional for the reference points of M and N as they are placed alongside the origin 'O' in the y-axis.

In figure 5(b), the coordinate for a will remain at $x=280$,

$y=0$ and $z=-60$. This is due to a fact the rotation of x-axis will not affect the position of a_1 as a_1 is located on the x-axis line which represents a line of rotation.

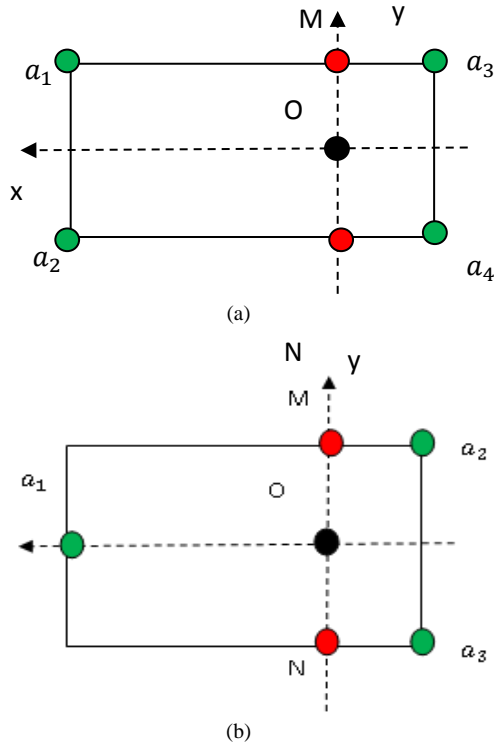

Figure 5: Positions of point M, N and the tip of the moving platform for rotation of θ_1 (a). Positions of point M, N and the tip of the moving platform for rotation of θ_1 in 3 Moving Cables (b). The red dot represents reference points while green dots represent the position of the connection points

$$M_2 = R_e^O M, N_2 = R_e^O N \quad (7)$$

$$a_1 = \begin{bmatrix} 280 \\ 0 \\ 0 \end{bmatrix} + M_2, a_2 = \begin{bmatrix} 280 \\ 0 \\ 0 \end{bmatrix} + N_2, a_3 = \begin{bmatrix} -120 \\ 0 \\ 0 \end{bmatrix} + M_2, a_4 = \begin{bmatrix} -120 \\ 0 \\ 0 \end{bmatrix} + N_2 \quad (8)$$

$$M_2 = R_e^O M, N_2 = R_e^O N \quad (9)$$

$$a_1 = \begin{bmatrix} 280 \\ 0 \\ -60 \end{bmatrix}, a_2 = \begin{bmatrix} 280 \\ 0 \\ 0 \end{bmatrix} + N_2, a_3 = \begin{bmatrix} -120 \\ 0 \\ 0 \end{bmatrix} + N_2 \quad (10)$$

C. For Rotation of θ_2 (Y-axis)

For rotation of θ_2 (y-axis), the ankle rehabilitation exercises that are involved are Assisted Circle Stretches, Dorsiflexion, Range of Motion, Plantarflexion and Balancing.

Figure 6 shows the position connecting points (green dots) and the reference points of P and Q (red dots which are located on the x-axis line). For Equation (11) and Equation (13), the reference point of P and Q will be rotated under y-axis presented as a new coordinate of P_2 and Q_2 . The addition of 100mm and the reduction of 100mm to P_2 and Q_2 in Equation (12) and Equation (14) is to obtain the final coordinate of the connecting points of a_1, a_2, a_3 and a_4 (4 Moving Cables) and a_3 and a_4 (3 Moving Cables). The

exception is a_1 in 3 Moving Cables as a_1 is P_2 .

The reason for presenting this calculation is the rotational transformation matrix can only be used to calculate the position of the connecting points based on origin 'O' and not based on the y-axis. However, there are exceptions to the reference points of P and Q as they are placed alongside the origin 'O' in the x-axis.

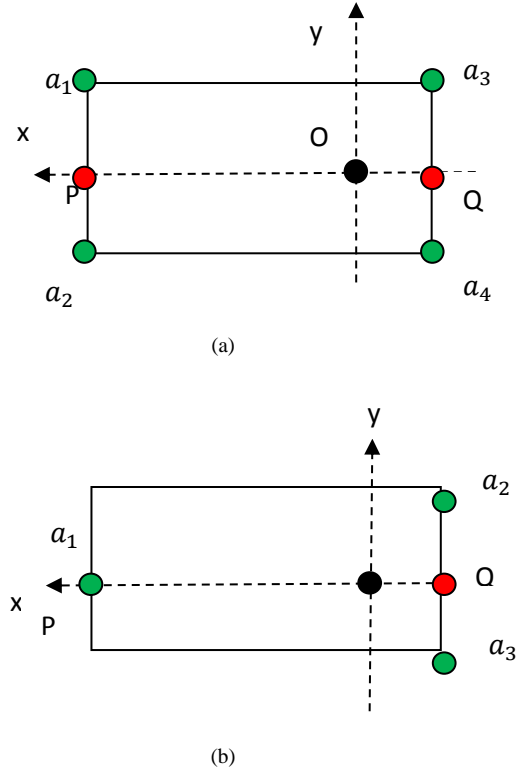

Figure 6: Positions of point P, Q and the tip of the moving platform for rotation of θ_2 in 4 Moving Cables (a). Positions of point P, Q and the tip of the moving platform for rotation of θ_2 for 3 Moving Cables (b). The red dot represents reference points while green dots represent the position of the connection points

$$P_2 = R_e^O P, Q_2 = R_e^O Q \quad (11)$$

$$a_1 = \begin{bmatrix} 0 \\ 100 \\ 0 \end{bmatrix} + P_2, a_2 = \begin{bmatrix} 0 \\ -100 \\ 0 \end{bmatrix} + P_2, a_3 = \begin{bmatrix} 0 \\ 100 \\ 0 \end{bmatrix} + Q_2, a_4 = \begin{bmatrix} 0 \\ -100 \\ 0 \end{bmatrix} + Q_2 \quad (12)$$

$$P_2 = a_1, Q_2 = R_e^O Q \quad (13)$$

$$a_1 = \begin{bmatrix} 0 \\ 0 \\ 0 \end{bmatrix} + P_2, a_2 = \begin{bmatrix} 0 \\ 100 \\ 0 \end{bmatrix} + P_2, a_3 = \begin{bmatrix} 0 \\ -100 \\ 0 \end{bmatrix} + Q_2 \quad (14)$$

D. For Rotation of θ_3 (Z-axis)

For rotation of θ_3 (z-axis), the ankle rehabilitation exercises that are involved are Assisted Circle Stretches, Ankle Inversion and Ankle Eversion.

Figure 7 shows the position of the connecting points (green dots) for 3 Moving Cables and 4 Moving Cables on a z-axis plane. The ' α_1 ' indicates the angle between the origin 'O' to a_1 and a_2 (4 Moving Cables) as 'Z'; and the point on the

middle between a_1 and a_2 . For 3 Moving cables, the rotational transformation matrix is used. On the other hand, ' α_2 ' indicates the angle between the origin 'O' to a_3 and a_4 (4 Moving Cables) or a_2 and a_3 (3 Moving Cables) as ' \mathbf{W} ' and the point on the middle between a_3 and a_4 or a_2 and a_3 (3 Moving Cables).

Equation (15) and Equation (16) present the calculation to obtain a new position for all connecting points after the moving platform is rotated under z-axis using trigonometry and Pythagoras theorem. Ideally, if the connecting points are rotating under z-axis only, the coordinate for z will be maintained for every movement it makes. The value of the coordinate will be represented as K.

The reason of introducing these calculations to calculate Z-axis is Equation (4) can't be used to calculate the position of a connecting point after rotating in z-axis as the position of connecting points are inaccurate with exception to the connecting points that are placed along with the origin. If rotated using Equation (15) and Equation (16), the connecting points will rotate on the z-axis and maintain the value of W and Z and also the distance between each connecting points are fixed.

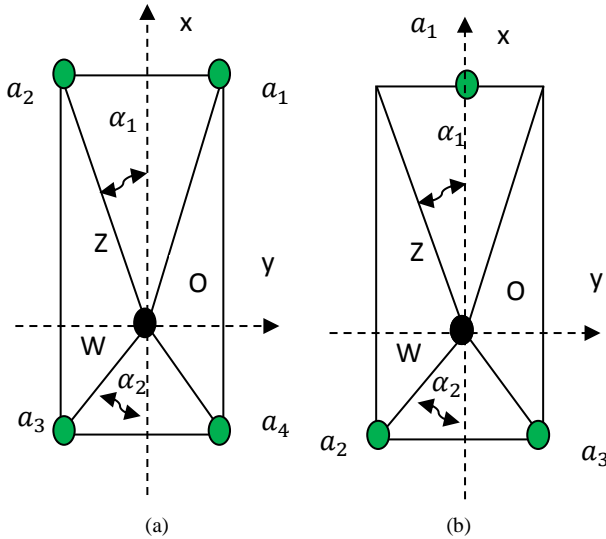

Figure 7: Positions of the tip of the moving platform for the rotation of θ_3 . The nodes in (a) represent 4 moving cables while the nodes in (b) represent 3 moving cables. The red dot represents reference points while green dots represent the position of the connection points

$$a_1 = \begin{bmatrix} \cos(\alpha_1 + \theta_3)Z \\ \sin(\alpha_1 + \theta_3)Z \\ -K \end{bmatrix}, a_2 = \begin{bmatrix} \cos(\alpha_1 - \theta_3)Z \\ -\sin(\alpha_1 - \theta_3)Z \\ -K \end{bmatrix}, a_3 = \begin{bmatrix} -\cos(\alpha_2 - \theta_3)W \\ \sin(\alpha_2 - \theta_3)W \\ -K \end{bmatrix}, a_4 = \begin{bmatrix} -\cos(\alpha_2 + \theta_3)W \\ -\sin(\alpha_2 + \theta_3)W \\ -K \end{bmatrix} \quad (14)$$

$$a_1 = \begin{bmatrix} R_z^{\theta_3} \\ 0 \\ 0 \end{bmatrix}, a_2 = \begin{bmatrix} -\cos(\alpha_2 - \theta_3)W \\ \sin(\alpha_2 - \theta_3)W \\ -K \end{bmatrix}, a_3 = \begin{bmatrix} -\cos(\alpha_2 - \theta_3)W \\ -\sin(\alpha_2 - \theta_3)W \\ -K \end{bmatrix} \quad (15)$$

V. DESIGN MODELLING

In this section, the data from Table 1 is used to model the trajectory of the moving platform. The purpose of this modelling is to present the position of the moving platform under certain ankle movement such as dorsiflexion or inversion etc. This is important so that the designers can easily determine the suitable position of the actuators that will

drive the moving platform. To calculate, $R_z^{\theta_3} a_i^e$ is obtained for each ankle movement under x-axis, y-axis or z-axis.

A. Modelling Position Trajectory Based on Rotation of x-axis θ_1

In Figure 8 are coordinate plots of a_i^e , when θ_1 was added up by 1° from -22° until 17° . Both 4 and 3 moving cables are showing the same path of trajectory and also symmetrical.

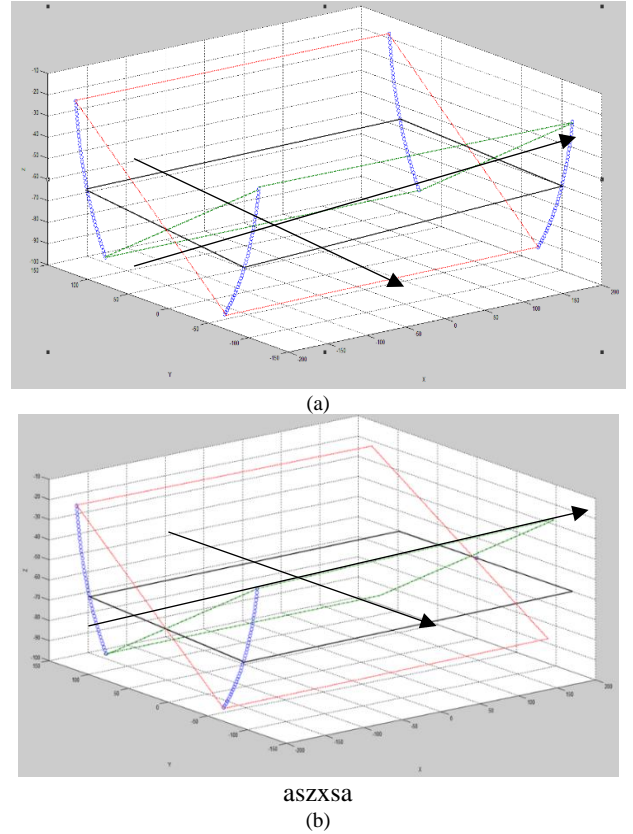

Figure 8: Positions of a_i^e for θ_1 (Blackline – Initial position, Green Line – Ideal maximum platform position for Eversion, Red Line- Ideal Maximum platform position for Inversion)

B. Modelling Position Trajectory Based on Rotation of y-axis θ_2

Figure 9 presents the plots of a_i^e where θ_2 was added up by 1° from -30° until 48° . Also for θ_2 both 4 and 3 moving cables are showing the same path of trajectory. Unlike rotation of x-axis θ_1 , the rotation of y-axis θ_2 for both 4 moving cables (Figure 9 (a)) and 3 moving cables (Figure 9 (b)) show the range of motion is greater on the front side of the moving platform compare to the back side of the moving platform. Nevertheless, this movement is compatible to the movement of the ankle where the front side of the foot can move under greater range compare to the movement on the back side of the foot.

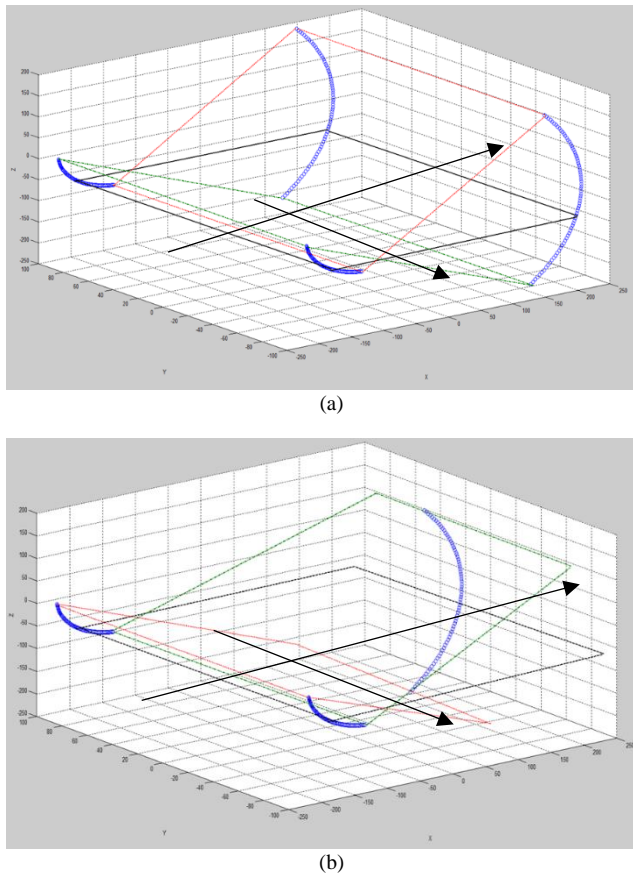

Figure 9: Positions of a_i^e for θ_2 (Blackline – Initial position, Green Line – Ideal maximum platform position for Dorsiflexion, Red Line- Ideal Maximum platform position for plantar flexion)

C. Difference Trajectory in 4 Moving Cables and 3 Moving Cables (Rotation of z-axis θ_3)

To perform the rotation of z-axis, the robot is needed to be configured by detaching all the cables that are attached from above the moving platform. Then the moving platform will be attached by the cable sideways in front of the tip of the moving platform. This also applied to both 4 Moving Cables and 3 Moving Cables. Therefore the trajectory for 3 moving cables is the same as 4 moving cables in Rotation of z-axis θ_3 . Figure 10 shows how configuration for rotation of z-axis is made.

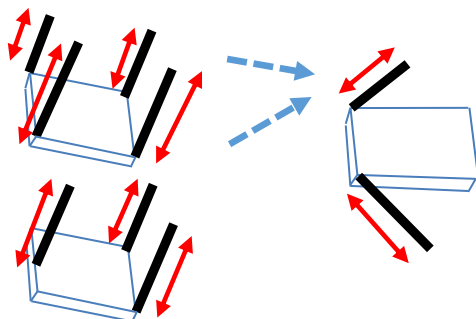

Figure 10: The configuration of the connecting points for the rotation of z-axis (sideways) for both 3 Moving Cables and 4 Moving Cables

D. Modelling Position Trajectory Based on Rotation of z-axis θ_3

Figure 11 shows the trajectory of the nodes of the moving platform when moving from -35° to 25° . Also, the trajectory for 3 moving cables (Figure 11(b)) is the same as 4 moving

cables (Figure 11(a)). Likewise for θ_2 , θ_3 has a range of motion is that is greater on the front side of the moving platform compare to the back side of the moving platform.

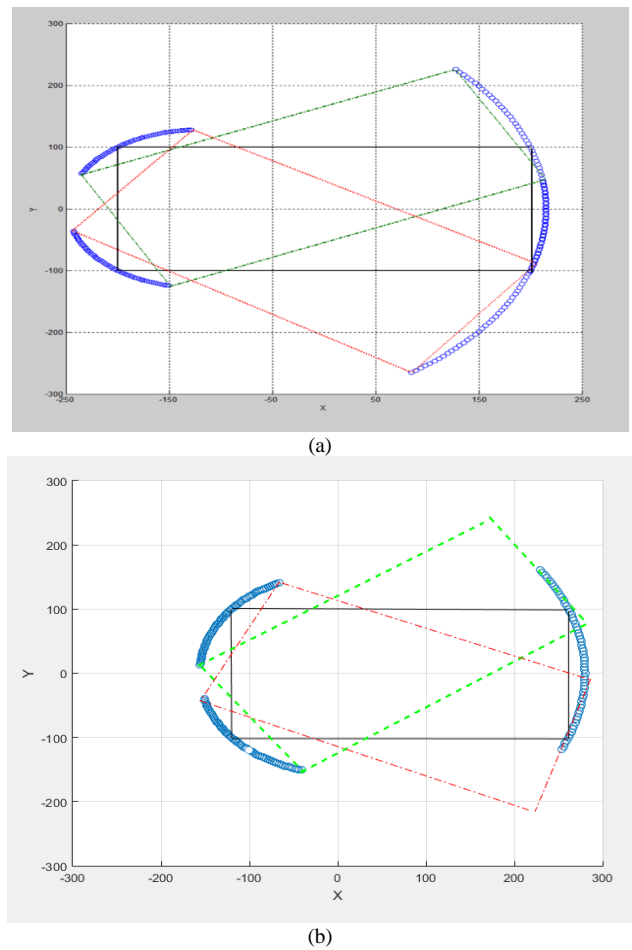

Figure 11: Positions of a_i^e for θ_3 (Blackline – Initial position, Green Line – Ideal maximum platform position for Abduction, Red Line- Ideal Maximum platform position for Adduction)

VI. DISCUSSION

Using IK calculation, the ideal trajectory of the moving platform for both 3 moving cables and 4 moving cables have been obtained. The inverse kinematics modelling on x-axis, y-axis and z-axis had presented that 3 Moving Cables are sharing the same trajectory as 4 Moving Cables. Therefore it is appropriate to select 3 Moving Cables for fabrication or physical prototyping as it is better than 4 Moving Cables regarding portability (require 3 actuators instead of 4 actuators). The modelling shows that the selection of every feature of a design cannot be determined through qualitative evaluation only such as conceptual design tools. Also, the design variations for each concept must be significantly different to each other concept designs for the tools to become effective [6].

In the later stage of the development, these calculations are needed to be verified through physical experimentation in order to determine its feasibility. Nevertheless, the calculations provided by this paper can help designers to predict the ideal trajectory of the moving platform through rotational transformation matrices, geometry and Pythagoras Theorem.

VII. CONCLUSION

Overall, the results presented the ideal trajectory of the moving platform based on the data that had been obtained from the literature. However, physical verification is needed to ensure the calculation that had been developed is compatible with the actual movement of the ankle. For the future works, verification through motion capture is planned to compare the ideal movement of the moving platform through calculation with actual movement through motion capture camera.

REFERENCES

- [1] C.L. Riegger, "Anatomy of the ankle and foot". *Phys. Ther.* vol. 68, no.12, 1988, pp. 1802–1814.
- [2] D.T.P. Fong, Y. Hong, L.K.P. Chan, S.H. Yung, K.M.A. Chan, "Systematic review on ankle injury and ankle sprain in sports". *Sports Med.* vol.37, no.1, 2007, pp.73–94.
- [3] J.A. Saglia. "Development of a high performance ankle rehabilitation robot – ARBOT", Thesis. King's College, London, 2010.
- [4] M.N.S.B.S. Aman and S.N. Basah, "Design and Kinematic Analysis of Parallel Robot for Ankle Rehabilitation", *Journal of Applied Mechanics and Materials.* vol. 446-447, 2014, pp 1279-1284.
- [5] K.H. Hunt "Structural kinematics of in parallel actuated robot arms. *J. of mechanisms, Transmissions and Automation in design*", vol. 105, 1983, pp.705 – 712.
- [6] M.N.S.B.S. Aman, S.N.Basah, W.K.Wan Ahmad, "Conceptual Design for Robot-Aided Ankle Rehabilitation", *Jurnal Teknologi UTM.* Vol. 76 no. 12, 2015.
- [7] W. Alcocer, L. Vela, A. Blanco, J. Gonzales, and M. Oliver, "Major Trends in the Development of Ankle Rehabilitation Devices," *Dyna*, vol. 176, pp. 45–55, 2012.
- [8] P.K. Jamwal. "Design and analysis and control wearable ankle rehabilitation robot", Thesis. University of Auckland, 2011.
- [9] C. Mummolo, L. Mangialardi, J.H. Kim. "Quantifying dynamic characteristics of human walking for comprehensive gait cycle" *Journal of Biomechanical Engineering*, vol. 135(September 2013), 2013, no. 91006.
- [10] C.E. Syrseloudis, I.Z. Emiris, T. Lilas, A. Maglara, "Design of a Simple and Modular 2-DOF Ankle Physiotherapy Device Relying on a Hybrid Serial-Parallel Robotic Architecture". *Applied Bionics and Biomechanics*, vol. 8, no. 1, 2011, pp. 101-114.