

Characterization of Lens Antenna in Wireless Communication System

N. I. Zaidi¹, M. T. Ali², S. A. Hamid², N. H. Abd Rahman² and Z. Tengah²

¹Antenna Research Group (ARG),

²Faculty of Electrical Engineering (FKE), Universiti Teknologi MARA (UiTM), Shah Alam, Selangor, 40450, Malaysia.
syahirahizzati92@gmail.com

Abstract—The focus of this paper is to design lens and analyze the lens behavior in lens antenna. This lens antenna is designed to enhance the gain of conventional antenna. A few factors that influenced the design of lens and gain of lens antenna is investigated. CST software is used to design the lens. At the end of this experiment, the lens gain increased from 8.782 dB to 11.07 dB.

Index Terms—Dielectric Lens; Lens Antenna; Lens Analysis; Shaped of Lens.

I. INTRODUCTION

Today, the wireless communications systems have become an integral part of daily life and continue to evolve in providing a better quality and experience for users. In wireless communication system, the demands for higher data rates of transmission keep increasing which includes high gain and high directivity [2-3]. Conventional antenna itself is not enough to provide the system with high gain. Therefore, lens antenna is one of the potential alternative to enhance gain [18],[10].

Generally, lens antenna are easy to design and assemble as they are mechanically rigid and are tolerable of surface imperfections and load distortion. Besides, lens antenna has a more desirable form factor due to its feed through characteristics and it also offers greater design flexibility to meet various demand such as high gain, high directivity, low side lobes and wide scan coverage [3], [17].

Basically lens antenna can be divided into two main parts, primary and secondary. A primary part consists of feed antenna while the secondary part consists of lens. The lens used to directs the wave from the feed antenna and prevent the signal from spreading in undesired direction. This type of antenna works on the principle of refraction (Snell's Law) [2-4], [8].

In this paper, three basic shape of lens which is flat lens, concave lens and convex lens is studied to determine the lens best shape with the highest gain. Then, the shape of lens that produced the highest gain is optimized. A few optimization parameters such as distance of lens from feeder, thickness of lens and edge of lens is tested. For feeder, any other type of antenna can also be a feeder. Commonly used antenna are patch antenna, horn antenna or open ended waveguide [17]. Hence, in this paper a basic antenna design (patch antenna) is proposed.

II. DESIGN CONSIDERATION

A. Design principle of dielectric lens

Figure 1 shows a dielectric lens with its general contour design S1 and S2, each represented by (x_1, y_1) and (x_2, y_2) .

Presume that the lens is rotationally symmetry, thus the only interest is on the lens cross section. It is considered that the dielectric constant of lens ϵ_r illuminated by a feed pattern originate from a phase center located at the origin of the coordinates. F is the distance between the origin and the lens first surface. Meanwhile T is the central thickness of lens and D is the diameter of lens aperture [3].

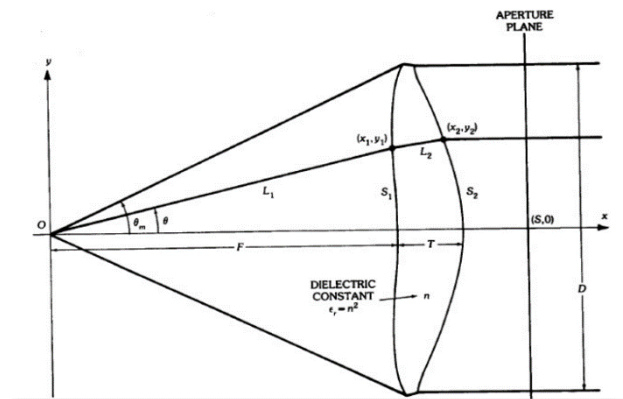

Figure 1: Geometry for dielectric lens design [3]

a. Rectangular Coordinate

Path length constrain is the most important condition in the derivation of lens profile. An aperture plane is established at $x=S$ for phase reference. Aperture plane is placed to the right of the lens for clarity. Generally, aperture phase distribution can be any rotationally function specified by $\varphi(\theta)$, where φ is the distance from the axis of lens. For a nonuniform aperture phase front the lens profiles will be a function of S. Usually, the aperture plane is very close to the lens hence the dependence is minor. However, when the aperture is assume to be uniform, the mathematically path length condition is given by [3].

$$(x_1^2 + y_1^2)^{1/2} + n[(x_2 - x_1)^2 + (y_2 - y_1)^2]^{1/2} - x_2 = (n - 1)T \quad (1)$$

Where the central ray is used as a path length reference and $n=(\epsilon_r)^{1/2}$ is the refractive index the lens, which is greater than unity for real dielectrics. In this case the S parameter for the reference plane is cancelled of both sides of Equation (1), and the focal length F became the initial condition for x_1 .

The second condition to be enforced is Snell's law derived from Fermat's principle. By using the differential of y_1 with respect to x_1 in (1) the slope of the lens at (x_1, y_1) is obtained:

$$\frac{dy_1}{dx_1} = \frac{nL_1(x_2 - x_1) - L_2x_1}{L_2y_1 - nL_1(y_2 - y_1)} \quad (2)$$

where:

$$L_1 : (x_1^2 + y_1^2)^{1/2}$$

$$L_2 : [(x_2 - x_1)^2 + (y_2 - y_1)^2]^{1/2}$$

Similarly, the slope of the lens contour at (x_2, y_2) is given by:

$$\frac{dy_2}{dx_2} = \frac{L_2 - n(x_2 - x_1)}{n(y_2 - y_1)} \quad (3)$$

b. Polar Coordinates

Sometimes it is more suitable to formulate the problem in terms of polar coordinates using the phase center as the origin. Referring to Figure 2, the path length constraint now becomes [3]:

$$r + n[R^2 + r^2 - 2Rr \cos(\theta - \phi)]^{1/2} - R \cos \phi = (n - 1)T \quad (4)$$

Snell's law on surface 1 is given by:

$$\frac{dr}{d\theta} = \frac{nRr \sin(\theta - \phi)}{n[R \cos(\theta - \phi) - r] - L_2} \quad (5)$$

And Snell's law on surface 2 leads to:

$$\frac{dr}{d\phi} = \frac{nRr \sin(\theta - \phi) - L_2R \sin \phi}{n[R - r \cos(\theta - \phi)] - L_2 \cos \phi} \quad (6)$$

where:

$$L_2 : n^{-1}[(n - 1)T + R \cos \phi - r] = [R^2 + r^2 - 2Rr \cos(\theta - \phi)]^{1/2}$$

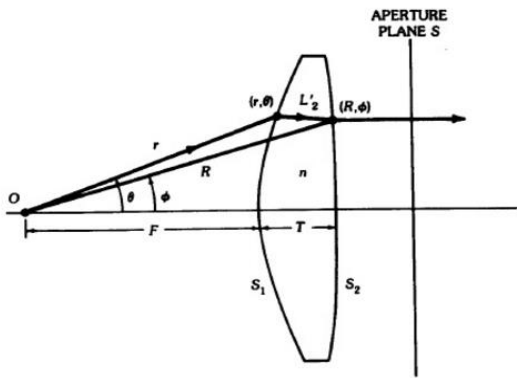

Figure 2: Dielectric lens in polar coordinate formula [3]

There are four variables which are x_1, x_2, y_1, y_2 in the lens formulation in Equations (1) – (3). As one of these quantities is considered to be the independent variable three independent equations are required to determine the lens contours.

B. Surface of Lens

a. Lens with a Flat Surface on S1

Figure 3 shows a lens with a flat surface on S1. By placing $x_1 = F$ and the slope on S1 equal to infinity, a parametric solution for S2 can be found from the path length constraint.

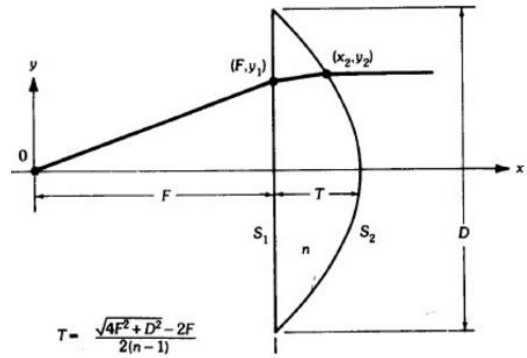

Figure 3: Convex lens with planar surface on S1 [3]

$$x_2 = \frac{[(n - 1)T - \sqrt{F^2 + y_1^2}] [\sqrt{[(n^2 - 1)y_1^2 + n^2F^2]} + n^2F\sqrt{F^2 + y_1^2}]}{n^2[\sqrt{F^2 + y_1^2} - \sqrt{[(n^2 - 1)y_1^2 + n^2F^2]}]} \quad (7)$$

$$y_2 = y_1 \left[1 + \frac{x_2 - F}{\sqrt{[(n^2 - 1)y_1^2 + n^2F^2]}} \right] \quad (8)$$

In this case the central thickness is:

$$T = \frac{\sqrt{4F^2 + D^2} - 2F}{2(n - 1)} \quad (9)$$

b. Lens with a Spherical Surface on S1

As shown in a Figure 4, if S1 is spherical the outer surface S2 is an ellipse specified by [3]:

$$R = \frac{(n - 1)(F + T)}{n - \cos \phi} \quad (10)$$

The equation is obtained by setting $\theta = \phi$ in Equation (6) and integrating the differential equation. In rectangular coordinates the solution is:

$$y_2 = \left[\left[\frac{x_2 + (n - 1)(F + T)}{n} \right]^2 - (x_2^2) \right]^{1/2} \quad (11)$$

In this case the central thickness is:

$$T = \frac{2F - \sqrt{4F^2 + D^2}}{2(n - 1)} \quad (12)$$

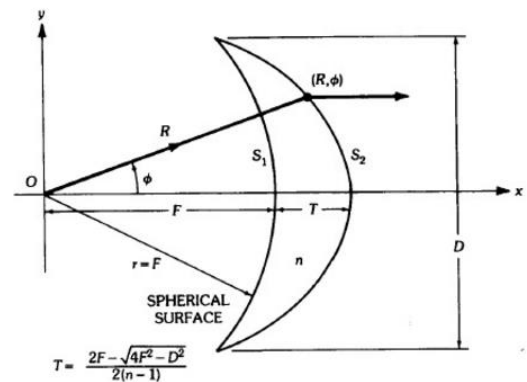

Figure 4: Lens with spherical surface on S1 [3]

C. Lens Material

In this project denser dielectric materials such as Teflon is used to construct lens. Teflon has a low dielectric constant which is 2.1 and 0.002 loss tangent. Thus, this characteristic

make the lens to produce high radiation efficiency and low loss.

D. Lens Shape

The shape of lens plays an important role in designing. The shape will influence the system performance such radiation pattern, radiation efficiency, directivity, gain, and side lobe of the system. There are 3 basic shape studied which are flat lens, concave lens, and convex lens. Each types of lens will use the same distance of lens from feed (50mm), height (70mm), width (240mm) and thickness (10mm). Figure 5 and Table 1 shows the preliminary results of the lens shape design.

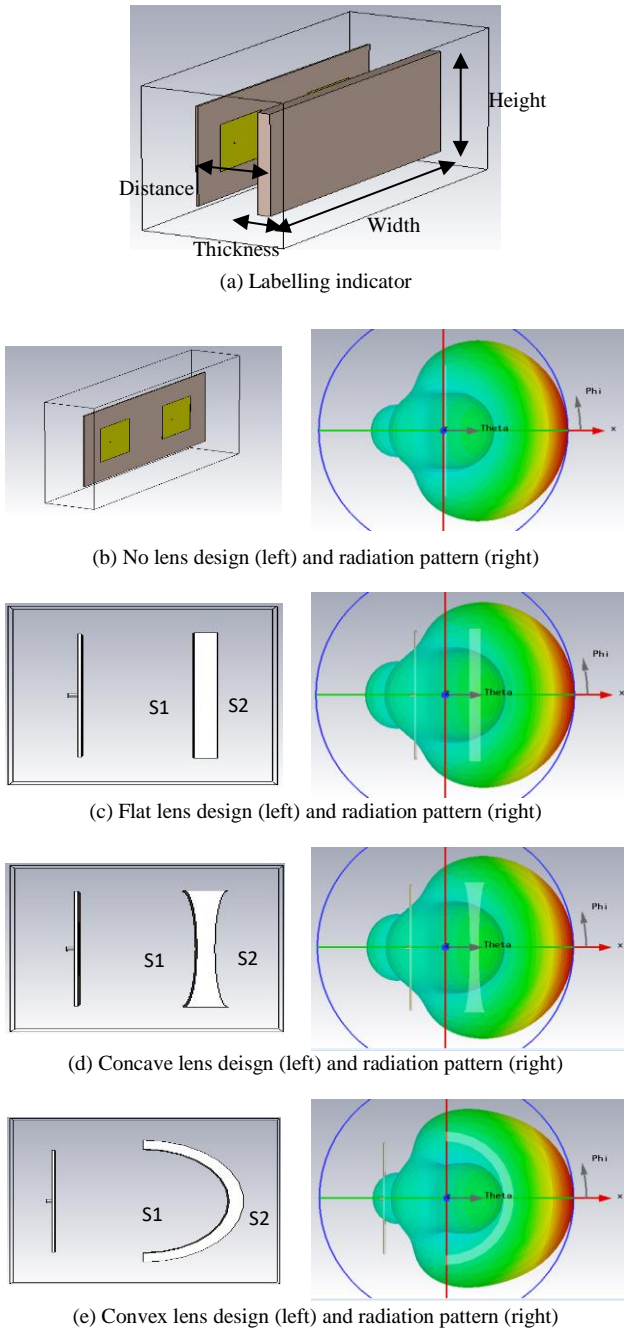

Figure 5: Lens design and radiation pattern

Table 1
Results of Monitored Parameters

Types of Lens	Gain (dB)	Radiation Efficiency (dB)	Directivity (dBi)	Side Lobe (dB)
No Lens	8.782	-1.991	10.77	-12.2
Flat	8.798	-2.009	10.81	-10.8
Concave	8.593	-2.505	11.10	-9.8
Convex	9.339	-2.053	11.39	-11.9

The above results in Table 1 shows that after the flat lens and convex lens are added to the antenna, gain of the system is improved. However, the gain of the system is the highest when convex lens applied. This is because the curve of the convex lens (S1 and S2) influenced the refraction of signal. The signal will converge and focusing to the center of lens, thus, increase the gain. Meanwhile for concave lens, the present of lens does not increase the gain of system but drop below the gain of conventional antenna (antenna with no lens). The decreasing of gain is also influenced by the concave lens curve (S1 and S2) as shown in Figure 1. When the signal from feeder radiated to the S1, signal will travel from less dense to dense medium (Snell's Law Principle) and focusing the signal. However, as the signal pass through S2, the signal diverge because of the shape of lens in S2. Therefore, the gain reduced.

As a result, convex lens is proposed to be the lens design because this design produced the highest gain. Next step, optimize the lens antenna.

III. RESULTS AND DISCUSSION OF LENS ANTENNA

In order to establish the best lens design with the best value of gain, optimization is done. The parameters measured are distance of lens from feeder, edge of lens, and thickness of lens.

A. Distance

In designing lens antenna, distance of lens from feeder is important. Distance between lens and feeder is optimized until the highest gain is determined. The width, thickness and height of the lens used remain constant.

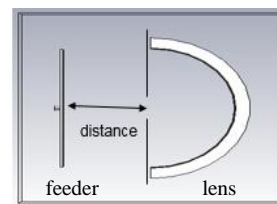

Figure 6: Distance of lens from feeder

Table 2
Results of Distance between Feeder (Source) and Lens

Distance (mm)	Gain (dB)	Radiation Efficiency (dB)	Directivity (dBi)	Side Lobe (dB)
0	8.931	-2.022	10.95	-10.0
10	8.770	-2.330	11.10	-10.2
20	8.810	-2.436	11.25	-10.5
30	8.981	-2.374	11.36	-11.0
40	9.156	-2.241	11.40	-11.5
50	9.339	-2.053	11.39	-11.9
60	9.403	-1.940	11.34	-12.2
70	9.374	-1.908	11.28	-12.2
80	9.329	-1.920	11.25	-12.1
90	9.249	-1.994	11.24	-12.0
100	9.224	-2.075	11.30	-11.9

From the observation, at distance corresponding to the maximum gain is 60 mm. Thus, for the next optimization distance of lens from feed used is 60mm.

B. Edge of Lens

The edge of lens is tested to investigate either it will affecting the gain of system. The thickness used for lens is 10mm, height is 70mm, width is 240mm, and distance of lens from feed is 60mm.

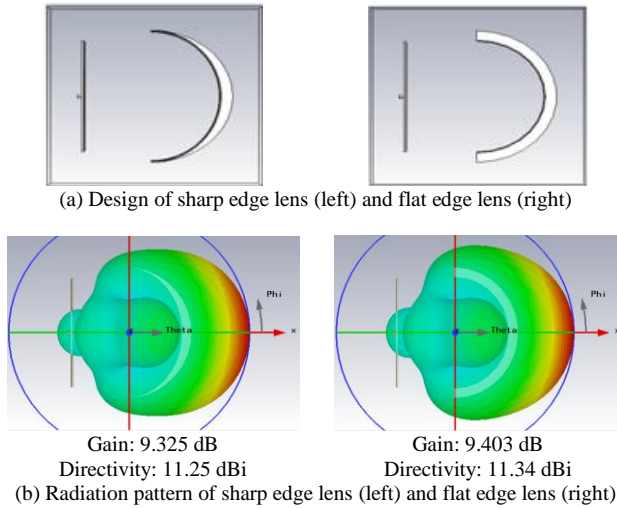

Figure 7: Edge of lens

Figure 7 shows that flat edge lens produce higher gain compared to the sharp edge lens. The radiation pattern of flat edge lens is more directive compared to the sharp edge lens. In this case both lens undergo refraction of signal. Refraction is the bending of a signal or wave when it enter from one medium to another medium of different speed. Both lens have a different thickness at the edge of lens. Therefore, when a wave propagate on a thick surface which is from fast medium to slow medium it bends toward the normal which is the boundary between two media. Thus, the wave produced will be more directives and high gain. Meanwhile, wave in sharp edge lens will propagate in thin surface. Wave propagation from fast medium to the less slow medium in sharp edge lens causing it slightly bends toward the normal. Hence, the wave produced will be less directives and less gain. For the design, flat edge lens will be used because it produce high gain.

C. Thickness

To test the suitable thickness of the lens there are two method will be used, which are thicken the outer surface of lens and thicken the inner surface of lens.

- a. Thicken the outer surface of lens. The inner radius of lens used is 60mm, distance is 60mm, and width is 240mm.

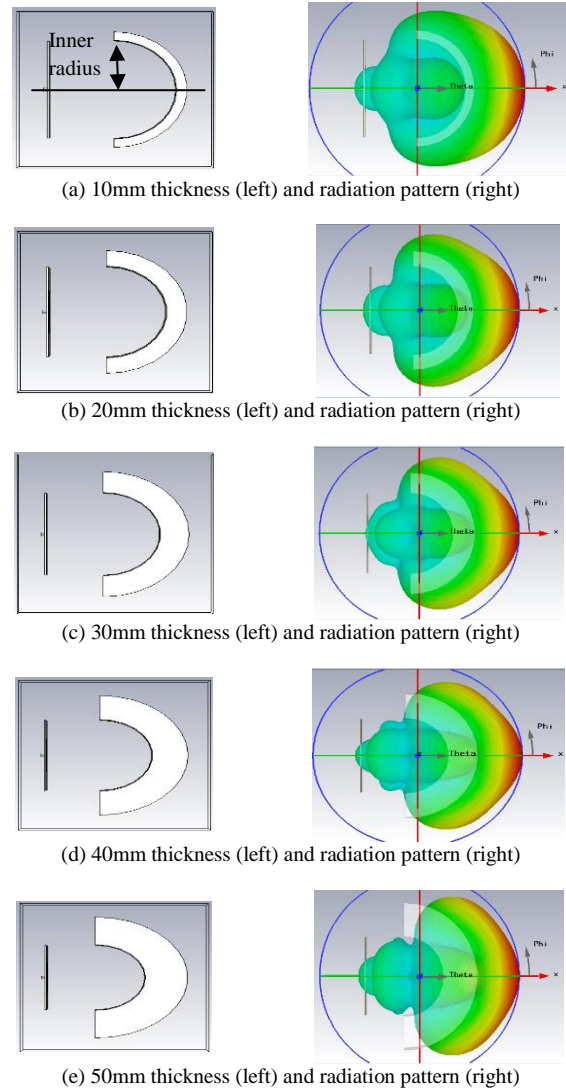

Figure 8: Thicken the outer surface of lens

Table 3
Results of Thicken the Outer Layer of Lens

Thickness (mm)	Gain (dB)	Radiation Efficiency (dB)	Directivity (dBi)	Side Lobe (dB)
10	9.403	-1.940	11.34	-12.2
20	9.557	-1.896	11.45	-11.7
30	9.526	-1.687	11.21	-11.3
40	9.205	-1.611	10.82	-10.1
50	8.944	-1.764	10.71	-8.7

The thickness of lens at 20mm showing the maximum gain. Hence, 20mm is used as the thickness of lens. Next, optimization will be done by thickening the inner surface of lens.

- b. Thicken the inner surface of lens. The outer radius of lens used is 80mm (use the previous thickness results), distance is 60mm, and width is 240mm.

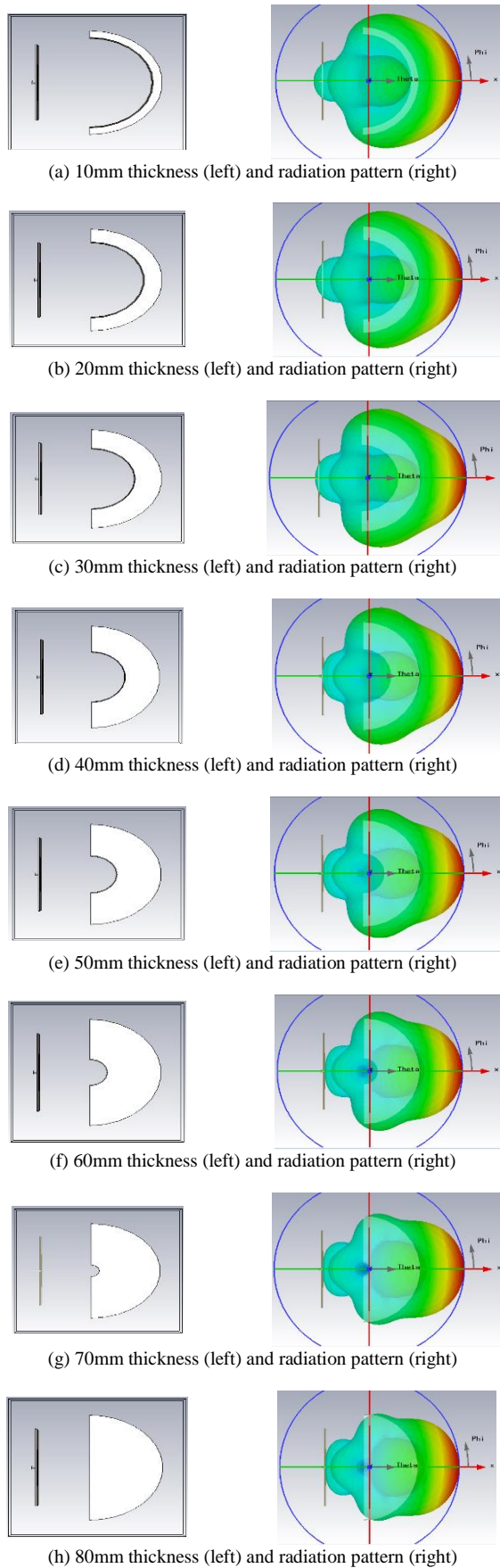

Figure 9: Thicken the inner surface of lens

Table 4
Results of Thickening the Inner Layer of Lens

Thickness (mm)	Gain (dB)	Radiation Efficiency (dB)	Directivity (dBi)	Side Lobe (dB)
10	9.246	-1.890	11.14	-12.0
20	9.557	-1.896	11.45	-11.7
30	9.721	-2.026	11.75	-11.3
40	9.853	-2.191	12.04	-10.9
50	10.03	-2.299	12.33	-10.5
60	10.17	-2.349	12.52	-10.2
70	10.21	-2.363	12.57	-9.8
80	10.21	-2.343	12.55	-9.6

In this case, there are two different thickness (70mm and 80mm) that shows the highest gain. Others parameter in the system such as radiation efficiency and directivity also shows only a slight different value between these two thickness of lens. Thus, the design of lens with thickness 80mm is chosen as it construct a simple design compare to the design of lens with inner thickness of 70mm. After configuring the thickness of lens, distance adjustment will be done again using 80 mm thickness.

D. Distance Adjustment Using Lens with 80mm Thickness (The Highest Gain)

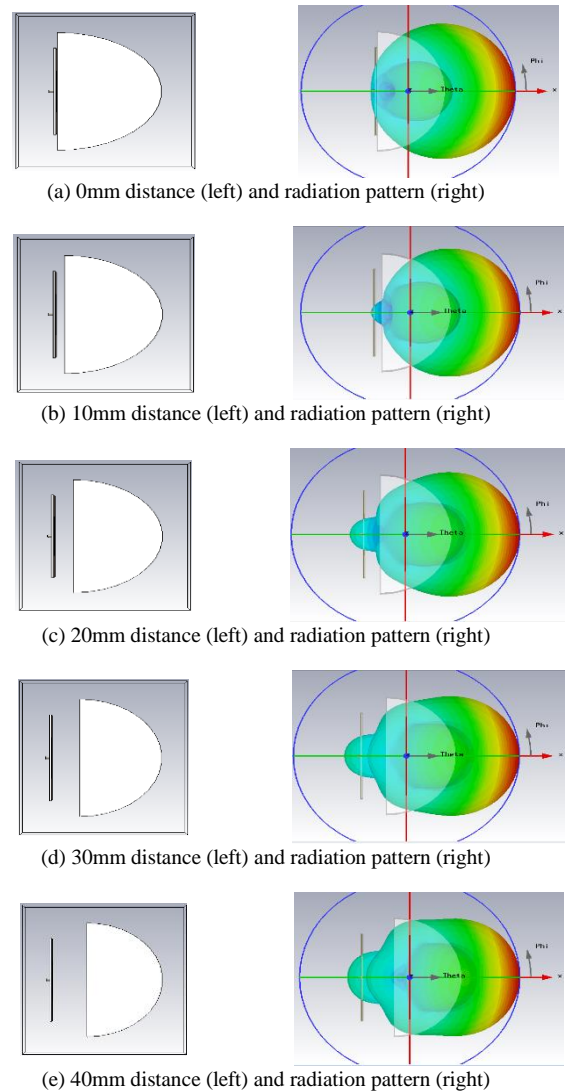

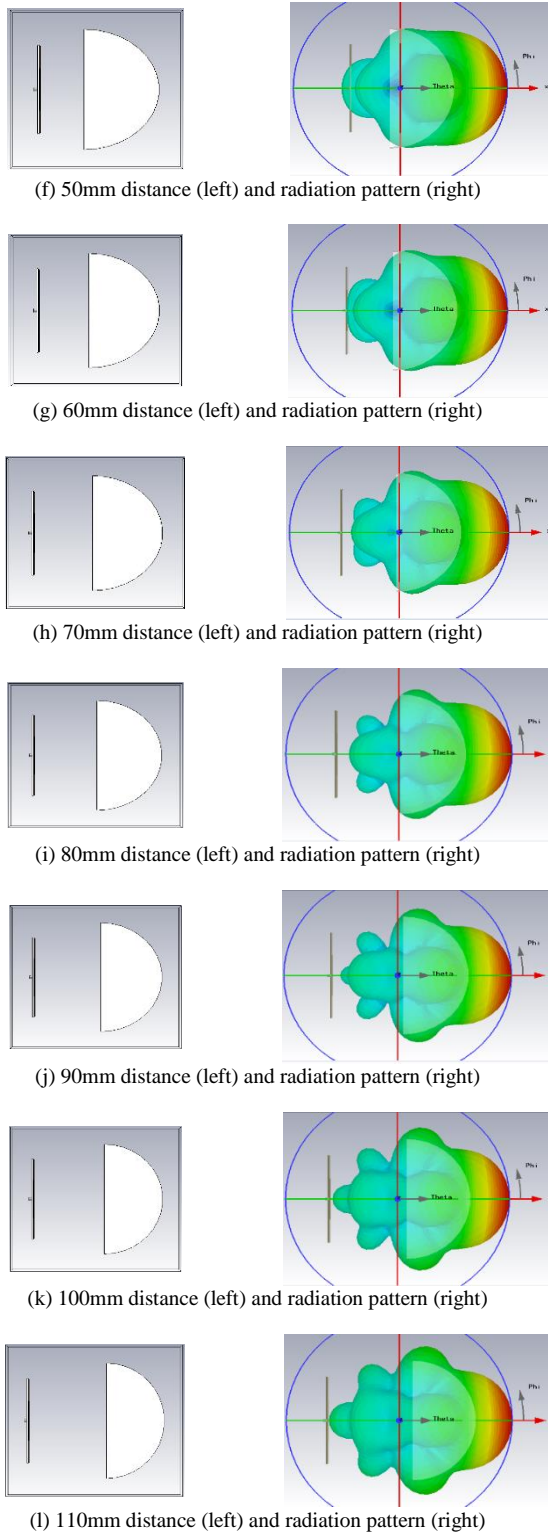

Figure 10: Distance adjustment for lens with 80mm thickness

Table 5 shows that by adjusting the distance of lens from feed again, using the 80 mm lens thickness (highest gain), the highest gain that this type of lens design could achieve is 11.07 dB, at 100 mm distance. At this point, the gain of lens antenna is the best as to compare with the conventional lens gain. There is a tremendous increase of gain which is from 8.782 dB (conventional antenna gain) to 11.07 dB (lens antenna using convex lens).

Table 5
Results of Distance Adjustment for Lens with 80mm Thickness

Distance (mm)	Gain (dB)	Radiation Efficiency (dB)	Directivity (dBi)	Side Lobe (dB)
0	10.34	-0.8215	11.16	-12.8
10	9.861	-1.700	11.56	-11.6
20	10.09	-1.668	11.76	-10.9
30	10.04	-1.806	11.85	-10.0
40	10.02	-1.979	12.00	-9.4
50	10.01	-2.238	12.24	-9.3
60	10.21	-2.343	12.55	-9.6
70	10.49	-2.346	12.84	-10.1
80	10.83	-2.200	13.03	-10.8
90	11.05	-2.034	13.08	-11.4
100	11.07	-1.929	13.00	-11.7
110	10.97	-1.881	12.85	-11.8

IV. CONCLUSION

As a conclusion, the gain of system increased from 8.782 dB (conventional antenna gain) to 11.07 dB (lens antenna using convex lens). In designing lens there are many factors that will influence the performance of a system. First thing to be considered before designing is the material of lens to be used. Next, the largest factor that contribute in the designing process is shape of lens. Lens shape will influence the diffraction of wave, thus enhance the gain and directivity of system. Other factors that also influence the lens performance are lens thickness, lens distance from feed, and lens edge. Those factors mention above is just only a few factors that can be analyze within this short period of research. For future studies, the studies about angle of radiation from feed to lens and the surface of lens is recommended.

REFERENCES

- [1] Constantine A. Balanis, "Antenna Theory Analysis and Design", Third Edition, John Wiley & Sons Publication.
- [2] John Thorton, Kao-Cheng Huang, "Modern lens antenna for communications engineering", John Wiley & Sons Publisher, Copyright @ 2013 by Institute of Electrical and Electronics Engineering.
- [3] Y.T.Lo and S.W.Lee, "Antenna Handbook Antenna Theory", Volume 2, Van Nostrand Reinhold Publisher.
- [4] Rajeswari Chatterjee, "Antenna Theory and Practice", Second Edition, New Age International (P) Limited Publisher.
- [5] Prashanth Kumar, Serhat Altunc, Carl E. Baum, C. Jerald Buchenauer, Christodoulou and Edl Schamiloglu, "Radially inhomogeneous spherical dielectric lens for matching 100-ps pulses into biological targets", IEEE Transactions On Plasma Science, Vol. 38, No. 8, August 2010.
- [6] Gaël Godi, Ronan Sauleau and Daniel Thouroude, "Performance of reduced size substrate lens antennas for millimeter-wave communications", IEEE Transactions on Antennas and Propagation, Vol. 53, No. 4, APRIL 2005.
- [7] Jorge R. Costa, Eduardo B. Lima, and Carlos A. Fernandes, "Compact beam-steerable lens antenna for 60-ghz wireless communications", IEEE Transactions On Antennas And Propagation, Vol. 57, No. 10, October 2009
- [8] Julian Baker, Ashwani Sharma, Bruno Camps-Raga, Clay Mayberry, "Dielectric lens design concepts to enhance antenna directivity and gain", International Journal of Innovative Research in Computer and Communication Engineering, Vol. 3, Issue 2, February 2015.
- [9] Mohd Shaik Honnur Vali and T. Rama Rao, "Concave lens integrated conical horn at 60 Ghz for energy efficiency wireless applications", 2013 International Conference on Advances in Computing, Communications and Informatics (ICACCI).
- [10] Marc Imbert, Anna Papió, Franco De Flaviis, Lluís Jofre, and Jordi Romeu, "Design and performance evaluation of a dielectric flat lens antenna for millimeter-wave applications", IEEE Antennas And Wireless Propagation Letters, Vol. 14, 2015.
- [11] Ikuo Awai, Takahiro Yamauchi, Shinpei Yasui, Yangjun Zhang, "Very thin artificial dielectric lens antenna made of printed circuit board", Ryukoku University, Proceedings of ISAP2007, Nigata, Japan.

- [12] N. Kamiya, T. Yasuzumi, R. Suga, O.Hashimoto, Y. Matsushita, Y. Matsuda, “ Positional dependence on primary radiator of metal plate lens antenna”, Proceedings of APMC 2012, Kaohsiung, Taiwan, Dec. 4-7, 2012.
- [13] S.Ravishankar, T.S.Rukmini, H.V Kumaraswamy, S.Sunit, Y.Karthik, P.Vinay and Arjun Ravishankar, “Analysis of hemispherical dielectric lens antennas for wireless application”, 2007 Asia-Pacific Conference on Applied Electromagnetic Processing.
- [14] *Carlos A. Fernandes*, “Shaped dielectric lenses for wireless millimeter- wave communications”, Instituto de Telecomunicaqtjes, Portugal
- [15] Mirio G. M. V. Silveirinha and Carlos A. Fernandes, “Shaped double-shell dielectric lenses for wireless millimeter wave communications”, Instituto de Telecommunications, Portugal.
- [16] Xidong Wu, George V. Elefieriades and Emilie van Deventer, “Design and characterization of single and multiple beam mm-wave circularly polarized substrate lens antennas for wireless communications”, University of Toronto, Canada.
- [17] Tin Komljenovic, “Lens atenna- analysis and synthesis at mm-waves”, University of Zareb, Faculty of Electrical Engineerig and Computing.
- [18] P.Piksa, S.Zvanovec, P.Cerny, “Eliptic and hyperbolic dielectric lens antennas in mm-waves”, Czech Technical University in Prague, Dept. of Electromagnetic Field.
- [19] Yoshihiko Kuwahara, and Takashi Maruyam, “Design of dielectric lens antennas by multi-objective optimization”, *Shizuoka University, Japan*.
- [20] Dr. S.Ravishankar and Prakash Biswagar, “Analysis of dielectric lens – adaptive array antennas for shaped beam applications”, Department of Electronics and Communication Engineering, RV College of Engineering, Bangalore, India.
- [21] Carlos A. Fernandes, Eduardo B. Lima, Jorge R. Costa “Dielectric lens antennas”, Handbook of Antenna Technology, Zhi Ning Chen (Editor), Springer 2016, ISBN-10: 981456043X.