

Analysis of Unclean Hand System Detection Using Template Matching Technique

Faradila Naim, Tuan Nur Amalia Tuan Arifien, Rosyati Hamid, Nurul Wahidah Arshad, Nurulfadzilah Hasan
Fakulti Kejuruteraan Elektrik & Elektronik, Univeristi Malaysia Pahang, 26600 Pekan, Pahang, Malaysia
faradilan@ump.edu.my

Abstract—The aim of this project is to audit the handwashing technique of hospital staff that may cause infection to the patients. This project is to detect unclean washed hands using image processing technique specifically template matching. The detection and recognition of palm in images is the key methodology of this paper. The prototype used for capturing hand images is a dark box with UV light and a camera. Target will need to apply Glogerm on their hands that imitate bacteria. Hence, when they wash their hands inappropriately, Glogerm can be seen in the captured images under the UV light as the unwanted stain on washed hands, the target handwashing technique needs to be improved. Templates of the missed area of washed hands are used to compare the correctness of hand washed techniques by the target. Data of 100 images were taken, results are; 100% accuracy of the hand image without Glogerm, 56.67% of the image that did not wash using water after applying the Glogerm and 45.45% accurate when user wash their hand by using water after applying Glogerm. The overall efficiency of the system in detecting the missed part is 51% accuracy. As a summary, this project accurately detects stain percentage that represents the missed part when applying the template matching technique.

Index Terms—Hand Detection; Hand Washing Detection; Stain Detection; Image Processing; Template Matching.

I. INTRODUCTION

The cleanliness is the keys to prevent the infections of any diseases. There are many standards of cleanliness around the world and the standard of cleanliness varied across cultures and countries. The importance of cleanliness must be emphasized especially in the health industry. According to New England Journal of Medicine, improperly washed or unwashed hands among the staff at the hospital may cause infections among the patients [1]. This can cost up to billions of dollars a year to cure the diseases or health issues caused by improper handwashing technique. Bacteria and viruses in the environment can easily be found on the hands since hands consistently making contacts with the surrounding. Improperly washed hands among hospital staffs who treated patients especially with the weakened immune system is a crucial issue, since these patients are prone to get infected with common cold, influenza, traveller's diarrhoea, hepatitis A and meningitis. Washing hands not only can save lives but also can protect the health. According to The Centers for Disease Control and Prevention (CDC), the regular handwashing with soap could save more lives than any vaccine or medical treatment [2]. This paper is aimed to develop an automatic vision system that detects the area of hands which are missed after being properly washed using the six-step handwashing technique. Image processing technique

specifically template matching is used to detect the stained hand.

Ahuja and Tuli introduced phase angle method and normalized correlation method to recognize the required object in the image. The template and input source are the variables that are compared to its corresponding pixel values in two images. In a comparison of the two methods, phase angle's processing time is much shorter but normalized correlation method detects the object more accurate [3]. The author of National Taiwan University introduced the technique of ring structure in grid-based template matching method. This technique is used to verify the movement of any regions that have been extracted and had been proposed in a grid-based structure for tackling the problem when there is big appearances difference between the two images. The contribution of this paper is in using the subtraction scheme to avoid the problem of camera vibrations by from the minimum filter. For effective appearance changes, a grid-based method was proposed to improve the accuracy of template matching. Ring structure has the advantage of shorter processing time to validate the candidate based on the integral image. This method is found to excel the other methods in terms of accuracy, robustness and stability. [4]

Parveen et al. in his review paper compare the number of template matching methods from the simplest to advanced methods. Cross-correlation techniques for image matching is not a robust method since the brightness of images caused huge discrepancies in object detection. A normalized cross-correlation (NCC) image matching solved the cross-correlation image matching but failed when there are changes in angle and size of the template in the image. In a more advanced method such as grayscale-based matching, orientation problems were eliminated. Meanwhile, edge-based-matching has the advantage of faster processing time since the object in the images will be compared to the edge of the template which has lesser pixels [7].

Fouda et. al, discussed three template matching algorithm; Sum of Absolute Difference (SAD), Coarse-to-Fine (CTF) and The Proposed One-Dimensional Algorithm (M1D). The SAD is a common method for similarity measure in pattern matching [11]. The SAD measure is useful when the additive noise distribution is exponential. However, SAD will fail when there are brightness and contrast changes between the template and input source [9]. CTF is a method known for the reduced computational cost for many template matching methods. Since it is using a low-resolution template in the initial matching or otherwise known as coarse matching, the number of pixel comparisons has been reduced dramatically. It will move to high-resolution marching if matching is successful in the initial (coarse) step. It is an iterative method until a convergence is met where template and source have

been completely compared. [8]. This shows that the complexity of the coarse-to-fine method is better than NCC and SAD techniques. MID method convert the image data from 2-D into 1-D and also be a modification for a 1-D method to avoid its sensitivity to noise. The template matching is more robust to noise within this method. One-Dimensional Algorithm (M1D) efficient for the time but it is sensitive to the noise.

II. METHODOLOGY

Like many vision system, this system incorporates a camera in the handwashing vision system to capture washed hand images under the ultra-violet (UV) light. These images then will be sent to the software for image processing in detecting the area of hand palm which had Glo Germ (missed area of washing) on it. The software then calculates the percentage area of the stained area on hand to decide if the target's technique of handwashing has followed the correct six steps handwashing techniques.

A. Hardware Enhancement

Previously, in a research paper by Naim et al. the prototype for the system was build using Perspex sprayed in black to give an opaque wall. This is to ensure that no other light is present inside the prototype to eliminate discrepancies in object detection [8]. In this paper, a new dimension with the same material is used to minimize the size of a more compact prototype. Dimension and the look of the prototype are shown in Figure 1 and Table 1. Width and length have been reduced by 20%, meanwhile, the height needs to be added by 10% for a complete hand palm image to be captured. In Figure 1, camera and UV light are attached to the top cover. Target will insert hand in the window that has black cloth attached to the window to minimize outside light effect.

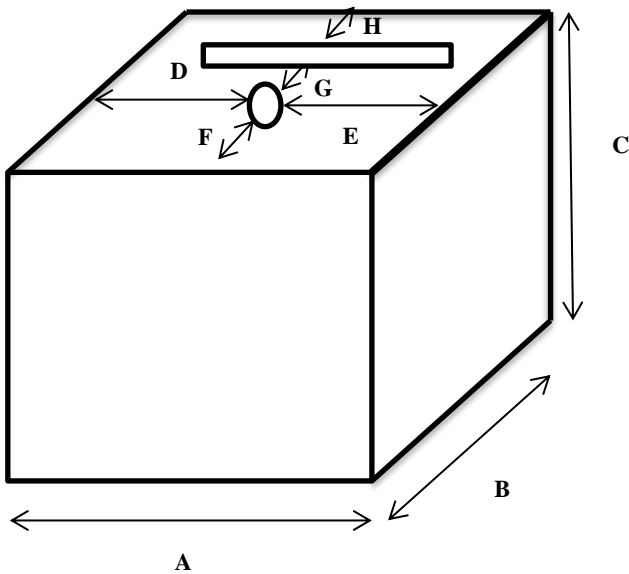

Figure 1: Prototype build

Table 1
The Dimension of the Prototype

Dimension measurement	Size (cm)
A - Height	41.7
B - Width	29.0
C - Length	43.5
D - (side of the box to camera)	19.5
E - (camera to side of the box)	20.5
F - (side of the box to camera)	5.3
G - (camera to UV lamp)	4.0
H - (UV lamp to side of the box)	8.0

B. Software Development

This paper contribution as compared to previous work done by Naim et. al, is the image processing technique used; where the detection of a stained area of hand was matched to the template as shown in Figure 2. Figure 2 shows the area of palm and back of the hand that is usually missed in red and sometimes missed in yellow. The area which is not highlighted in the image must not be missed. Hence, if the stain is detected in the not missed area, the vision system should give a result of bad handwashing technique for the target. In this study, the data is only focused on left palm hand detection.



Figure 2: Guidelines for the area on hands which frequently and sometimes missed area after washing. [9]

The procedure for handwashing audit using vision system are; 1) hand will be inserted into the prototype, 2) camera will preview the image in 5 seconds, 3) camera captures the image and sends the image to the computer. 4) the computer processes the image to detect the stain of the image on hand, 5) the area of the stain image is calculated and divided by overall area of palm to find the percentage of image unclean hand detected using template matching method.

The template mask used in detecting a missed area of handwashing are developed by applying image processing techniques to the image in Figure 2 which only the palm image is used. The detected stain area will be compared to this template.

The steps in detecting the stains on hand and percentage calculation of the stain using template matching is as follows; 1) apply threshold to the input image of washed hands in HSV domain to detect the hand area and the stained area, 2) the stained image is compared to the template by cropping and resizing the stain image to match the size of the template image, 3) only the overlapped area of the stain and area of not missed and frequently missed will be detected for percentage calculation, 4) decision will show the percentage value with the image of stain detected on hand along with statement of

how good handwashing techniques had been applied. This project states that if the percentage area of the frequently part is greater than 10 percent, we concluded that technique of the hand wash is bad. Then, if the percentage area of sometimes part is greater than 50 percent, the technique of the hand wash can be improved. Besides that, this project also compares between frequently and sometimes part that missed. The percentage calculation area is used in getting the value of the detection. This method is used to get the accuracy and efficiency of the unclean hand system of the prototype. The formula used for percentage calculation is stated in Equation (1).

$$P \% = [a/b] \times 100\% \quad (1)$$

where,

P = Percentage of color stain detection;

a = Number of Pixels where Orange/Yellow Stain Detected;

b = Number of Pixels where Orange/Yellow Template Detected.

III. RESULTS

In this section, image processing results will be discussed along with the overall system results. The first step in image processing techniques for the system is creating the template mask. In the development of template mask, the threshold values in HSV (hue saturation value) color domain plays a critical role to separate out the frequently and sometimes missed area from the hand palm image. Table 2 shows the threshold values used to create the template mask images as shown in Figure 3. All three planes in HSV domain will be threshold based on Tale 2. In Table 2, the orange mask is the frequently missed area threshold for hue is between 0.051 to 0.987. Figure 3(b) is the binary image masks used to match the stain for sometimes missed area after the threshold values are applied.

Table 2
Threshold values of the template image

Mask	Hue, H	Saturation, S	Value, V
The orange mask	0.051 - 0.987	0.621 - 0.917	0.826 - 0.980
The yellow mask	0.081 - 0.127	0.474 - 0.925	0.683 - 1.000
The outline mask	0.024 - 0.162	0.000 - 0.149	0.511 - 1.000

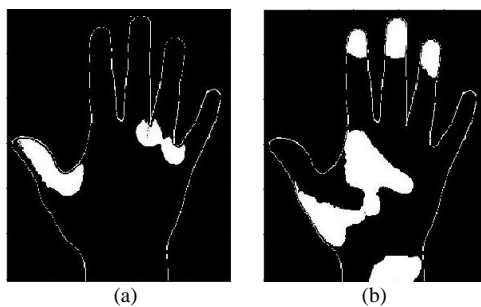

Figure 3: (a) Template image for the frequently missed area, (b) Template image for sometimes missed area.

Figure 4 is the captured input image when the user inserts their washed left palm after applying Glogerm on their hands. The orange area on the palm is the missed area of washing.

Applying threshold value in Table 3 to the input image, the orange areas on hand will be detected as the stains as shown in Figure 5. Figure 5 shows a binary image of detected stain on hand palm for the frequently missed area and sometimes missed area separately. The detected stain images will be matched to the template to calculate the percentage of missed area based on the mask.



Figure 4: The original input image

Table 3
Threshold Values of the Hue, Saturation and Value According to the Detection Parts.

Object	Hue value	Saturation value	Value, V
Frequently missed part detection on the palm	0.064 - 0.945	0.579 - 1.000	0.813 - 1.000
Sometimes missed part detection on the palm	0.933 - 0.972	0.533 - 0.643	0.459 - 0.573
Outline of the Original Image	0.808 - 0.007	0.302 - 0.702	0.093 - 0.132

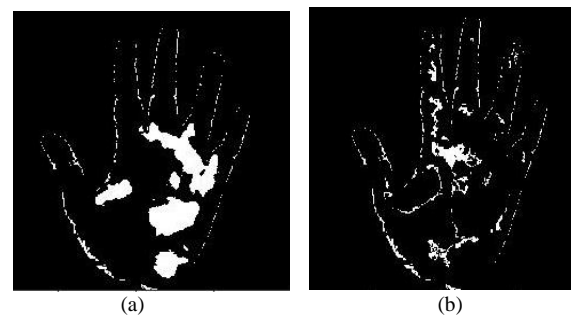

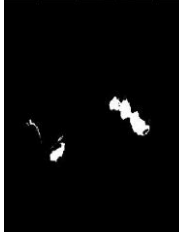

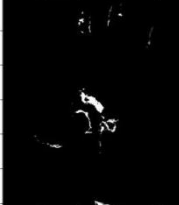

Figure 5: (a) Binary image of stained hand (frequently missed area) (b) Binary image of stained hand (sometimes missed area)

Table 4 demonstrates the template matching operation in order to acquire the overlapping area between the input image and template. In order to find the overlapped area, the stained images were cropped and resized following the template ratio. Then, pixel by pixel matching is done by pixel multiplication of both binary images. This will result in a new binary image where only the pixels that appear in stain image in the area of mask template. In Table 4, looking at the overlapped image in the second row of the table, the area detected are in the bound of the template area and all other stained not designated to the area in the template is removed. Same goes for the sometimes-missed area, the overlapping image result shows only the stains on three fingers as highlighted in the template. These overlapped pixels areas are then used to calculate the percentage of the missed area based on Equation (1). The percentage values will be used to make

the decision if the handwashing techniques are appropriate or need improvements. The overlapping areas are then embedded back to the original input image so that the user can visualize the detected stain area on hand palm based on the template. This is shown in Figure 6 where green is the stain for the frequently missed area, and blue is the sometimes missed are with hand outline.

Table 4
Template Matching Applied to Acquire the Overlapping Area of Stains to Calculate Its Percentage

Sample	Template	Overlapped
		
		

The total images used for data testing are 102 images. The images were taken in three conditions; (a) Palm without Glogerm and not washed, (b) palm with Glogerm and not washed, and (c) palm with Glogerm and washed according to the six steps handwashing techniques. The target used for the images are 10 people.

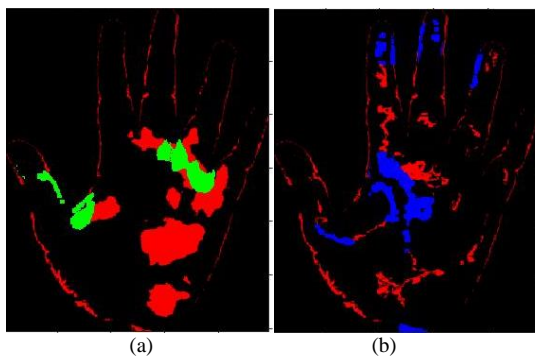

Figure 6: The overlapping areas embedded into one image showing the stains area according to the template. (a) based on frequently missed template (b) based on sometimes missed template

Table 5 shows the overall results of each group of images when given as input to the software system. For plain palm, 100% accuracy obtained for the system can accurately segment out the background from the palm images. This is important since the first step in any image processing is to segment out the background correctly. It can be concluded that the overall accuracy of detection is 64%. Although, the highest false detection is in the unwashed palm with Glogerm 57% accurate. This is due to so many stain pixels detected

that lead to false detection compared to the template given. 45% accuracy for washed palm with Glogerm signifies the poor noise detection in getting the overlapping area.

Table 5
Detection Results for All Data Samples

Data Categories	Total image samples	Correct stain detection (number of images)	Wrong stain detection (number of images)
Plain palm	28	28	0
Glogerm without wash	30	17	13
Glogerm with wash	44	20	24
Total	102	65	37

IV. CONCLUSION

The template matching method applied to calculate the percentage of stain detected as compared to the designated area guidelines has been successfully implemented. There is room for improvements for this method to accurately detect the stains on the hand palm. This work plays an important role in handwashing audit to have it done automatically.

ACKNOWLEDGMENT

This research was supported by the University’s Research Grant (RDU170130) from Universiti Malaysia Pahang. We thank our colleagues from Hospital Universiti Sains Malaysia who provided insight and expertise that greatly assisted the research, although they may not agree with all of the interpretations/conclusions of this paper.

REFERENCES

- [1] Handwashing: Clean Hands Save Lives. [Online]. Available<<http://www.cdc.gov/handwashing/>> [Accessed : January 27, 2016]
- [2] K. Cox, A. Johnson, and S. Davis, “Wash Way Less Colds Flu,” 2016. [Online]. Available: <http://www.coxfamilypractice.com/wash-way-less-colds-flu/>.
- [3] Kavita Ahuja and Preeti Tuli , “Object Recognition by Template Matching Using Correlations and Phase Angle Method”, *International Journal of Advanced Research in Computer and Communication Engineering* Vol.2, Issue 3, March 2013
- [4] Four departments from National Taiwan Ocean University, *Grid-based Template Matching for People Counting*, 30 June 2010
- [5] Nazil Perveen, Darshan Kumar and Ishan Bhardwaj, “An Overview on Template Matching Methodologies and Its Application”, *International Journal of Advanced Research in Computer and Communication Engineering* Vol.2, Issue 10, October-2013
- [6] Y. M. Fouda, “A Robust Template Matching Algorithm Based on Reducing Dimensions”, *Journal of Signal and Information Processing*, 6, 109-122, 2015
- [7] Mahmood A, and Khan S. “Correlation Coefficient Based Fast template <Atching Through Partial Elimination” , *IEEE Transaction on Image Processing*, 21, , 2099-2108, (2012)
- [8] F. Naim, R. Jaafar, N. W. Arshad, R. Hamid and M. N. Razali, "Unclean hand detection machine using vision sensor," *2013 Saudi International Electronics, Communications and Photonics Conference*, Fira, 2013, pp. 1-4. doi: 10.1109/SIEPCPC.2013.6550750
- [9] Best Sanitizers Inc., “Hand Hygiene,” 2013. [Online]. Available: <http://gobrandstand.com/index.php?/hand-hygiene/>.
- [10] Fouda, Y.M., “One- Dimensional Vector Based Template Matching”, *International Journal of Computer Science and Information Technology*, 6, 47-58, 2014.