

An Improved Multipath Estimating Delay-Lock-Loop Method Based on Teager-Kaiser Operator

Ji YuanFa¹, Tian LianJie¹, Sun XiYan¹, YAN Suqing¹, Kamarul Hawari Ghazali² and S. Khatuni²

¹Guangxi Key Laboratory of Precision Navigation Technology and Application, Guilin University of Electronic Technology

²Universiti Malaysia Pahang

yansuqing@guet.edu.cn

Abstract—In the satellite navigation system, multipath signal propagation effect is the main source of errors to the receiver positioning accuracy. Research has been done on multipath mitigation algorithms but their implementation towards sub-optimal or optimal receiver is in demand. One of the key multipath mitigation algorithms is Multipath Estimating Delay-Lock-Loop (MEDLL), which suffers from large amount of computational complexity, poor real-time performance and error accumulation. To overcome these drawbacks, an improved MEDLL algorithm is proposed here by combining it with the Teager-Kaiser (TK) algorithm and residual signal estimation -- named TK-MEDLL. Simulation results show that the algorithm can accurately estimate the number of multipath signal components, and improve the estimation accuracy of the signal parameters. Besides, TK-MEDLL can separate the multipath from the composite signal, restore the direct signal, and thus effectively suppress the multipath signal. Hence, the time delay estimation accuracy is improved by 0.015chip, whereas the estimation error is reduced by 5%. Overall, the algorithm reduces the computational complexity and improves the real-time performance of signal processing, which is of great significance for satellite communications.

Index Terms—Multipath Mitigation; TK Algorithm; Residual Estimation; Multipath Estimation Delay Lock Loop.

I. INTRODUCTION

Multipath interference is one of the important factors that affect the accuracy of the receiver. The addition of the multipath signal will cause the deformity in the correlation function. Using the traditional standard correlator, the multipath effect may lead up to several tens of meters error in the code tracking loop. Present researches on multipath mitigation usually focus on two aspects: (i) at the front-end of the receiver, use special antennas such as choke ring antenna and right-handed circularly polarized antenna with antenna array [1], and (ii) perform digital signal processing to suppress multipath. The signal processing part can be divided into two categories. The first category is based on the correlator technology. An improved narrow correlation technique is proposed in [2] to improve the anti-multipath performance by reducing the distance between the correlators. Strobe correlator technology is proposed in [3] with a stronger multipath suppression, using four correlators to detect the phase. There are other related proposed research including early and late correlator slope technology [4,9], vision correlator technology [5] and so on. The other category is based on maximum likelihood estimation, such as the MEDLL techniques [6,7,12]. MEDLL algorithm has a better performance in suppressing short multipath. But the main disadvantages of the MEDLL algorithm are the accumulation

of errors, a large amount of computational complexity, and poor real-time signal estimation.

To mitigate these problems, this paper proposes a TK-MEDLL optimization algorithm based on the combination of TK operator and MEDLL operator. The improved algorithm can improve the precision of parameter estimation and the efficiency of signal processing, which can reduce the error accumulation. Accurate estimation of the parameters can be a precise revert of multipath signals and restoration of the direct signal.

II. INTRODUCTION OF MULTIPATH ESTIMATING DELAY-LOCK-LOOP (MEDLL) ALGORITHM

A. The Principle of MEDLL

MEDLL is a method, which uses the maximum likelihood estimation criterion to estimate the signal amplitude, time-delay and phase parameters. Through the estimation of the parameters, the signals mixed by Line of Sight (LOS) signal and multipath signal are constructed, then, the multipath signal is removed from the composite signal to restore the direct signal, achieving the effect of multipath suppression. Its principle block diagram is shown in Figure 1.

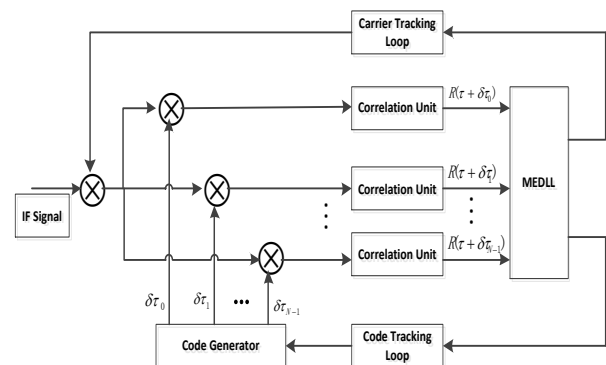

Figure 1: Block diagram of MEDLL

The estimated parameters are obtained by the method of minimizing the mean square error function [7] as shown in Equation (1).

$$L[r(t)] = \int_0^T [r(t) - s(t)]^2 dt \quad (1)$$

where, $r(t)$ is the input signal, $s(t)$ is the estimated signal as

$$s(t) = \sum_{i=0}^M \hat{a}_i P(t - \hat{\tau}_i) \cos(\omega t + \hat{\theta}_i),$$

where, \hat{a} , $\hat{\tau}$, and $\hat{\theta}$ are signal amplitude, time and phase delay estimation respectively.

The estimated parameters are obtained through the partial derivation of Equation (1) as shown in Equations (2.1-2.3).

$$\hat{\tau}_i = \max_{\tau} [\text{Re}\{[R_x(\tau) - \sum_{\substack{n=0 \\ i \neq n}}^{M-1} \hat{a}_n R(\tau - \hat{\tau}_n) e^{j\hat{\phi}_n}] e^{-j\hat{\phi}_i}\}] \quad (2.1)$$

$$\hat{a}_i = \text{Re}\{[R_x(\hat{\tau}_i) - \sum_{\substack{n=0 \\ i \neq n}}^{M-1} \hat{a}_n R(\hat{\tau}_i - \hat{\tau}_n) e^{j\hat{\phi}_n}] e^{-j\hat{\phi}_i}\} \quad (2.2)$$

$$\hat{\phi}_i = \arg[R_x(\hat{\tau}_i) - \sum_{\substack{n=0 \\ i \neq n}}^{M-1} \hat{a}_n R(\hat{\tau}_i - \hat{\tau}_n) e^{j\hat{\phi}_n}] \quad (2.3)$$

Due to the complexity of the multipath environment, the determination of the number of multipath parameters is also the key point. The traditional MEDLL algorithm obtains the number of multipath by partial derivation of Equation (1), sub M , as shown in the Equation (3).

$$\hat{M} = \max_M \left[\text{Re} \left\{ \sum_{i=0}^{M-1} \hat{a}_i R_x(\hat{\tau}_i) e^{-j\hat{\phi}_i} \right\} \right] \quad (3)$$

From those equations above (1-3) and analysis of the principle of MEDLL, we can draw the following conclusions:

- i. The error accumulation of MEDLL is a serious problem because of the dependence of the parameter estimation in the signal component.
- ii. This method may have a wrong estimation on the number of multipath signals, so that the multipath signal cannot be completely stripped off from the composite signal, and thus losing the capability of restoring the direct signal fully.

B. The Principle of the Proposed TK-MEDLL Algorithm

To overcome the MEDLL shortcomings, an improved MEDLL algorithm is proposed, which is based on the optimization algorithm of Teager-Kaiser (TK) operator [8] combined with residual estimation. TK operator is usually used for speech signal processing to measure the amplitude of vibration and the frequency of the signal. It is a simple algorithm with high efficiency and easy to implement. The algorithm can track the instantaneous changes of the signal, which provides a theoretical basis for the identification of multipath signals in the composite signal [11].

For a complex signal, $x(t)$, the continuous TK operator expression is shown in Equation (4).

$$\psi_c(t) = \frac{d^2 x(t)}{dt^2} \frac{d^2 x^*(t)}{dt^2} - \frac{1}{2} \left[\frac{d^2 x(t)}{dt^2} x^*(t) + x(t) \frac{d^2 x^*(t)}{dt^2} \right] \quad (4)$$

The discrete TK operator is expressed in Equation (5).

$$\psi_c[x(n)] = x(n-1)x^*(n-1) - \frac{1}{2} [x(n-2)x^*(n) + x(n)x^*(n-2)] \quad (5)$$

When the signal is passed through the correlator, we can get the complex signal correlation function, $R(t)$, as shown in Equation (6).

$$R(t) = \sum_{i=0}^M a_i \Delta(t - t_i, T_c) e^{j\theta_i} \quad (6)$$

where, a_i, t_i, θ_i are respectively the amplitude, time and phase delay estimation of i^{th} paths; T_c is the Pseudo code duration; and $c(t)$ is the Pseudo code sequence; and the

$$\text{variance of } T_c, \Delta(t, T_c) = \begin{cases} \frac{1}{T_c} \int_{T_c} c(t)c(t-\tau) dt, |t| < T_c \\ 0, \text{ other} \end{cases}$$

Through bringing the composite signal correlation function into the TK operator, We can get the resultant equation as shown in the Equation (7).

$$\begin{aligned} \psi_c[R(t)] = & \frac{1}{T_c^2} \left\{ \left[\sum_{i=0}^n a_i \text{sign}(t - t_i) \prod(t - t_i, T_c) \cos \theta_i \right]^2 \right. \\ & \left. + \left[\sum_{i=0}^n a_i \text{sign}(t - t_i) \prod(t - t_i, T_c) \sin \theta_i \right]^2 \right\} \\ & + \frac{1}{2T_c} \left\{ R^*(t) \left[\sum_{i=0}^n a_i \delta(t - t_i) e^{j\theta_i} \right] \right. \\ & \left. + R(t) \left[\sum_{i=0}^n a_i \delta(t - t_i) e^{-j\theta_i} \right] \right\} \quad (7) \end{aligned}$$

where, $\prod(t, T_c) = \begin{cases} 1, |t| \leq T_c \\ 0, \text{ other} \end{cases}$; $\delta(t)$ is the impulse

function; and $\text{sign}(t)$ is a symbolic function.

From Equation (7), we can see that the multipath signal delay can clearly be identified. At the same time, we can also get the number of multipath signals and delay information.

In order to verify the validity and accuracy of the TK algorithm, A multipath signal which is delayed 0.3 chip is added to the LOS signal. In Figure 2, the horizontal coordinate is the sampling point, and the 400th point is the LOS signal.

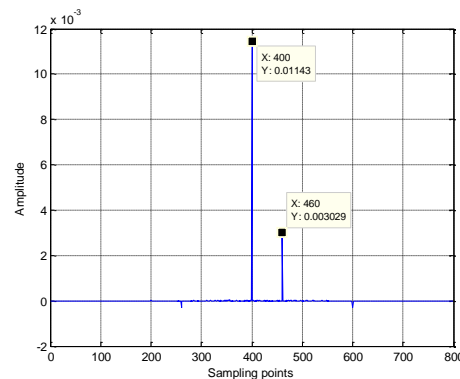

Figure 2: Signal discrimination using TK operator curve

From the Figure 2, we can also see that at 400 and 460 points, two obvious pulses occur as direct and multipath signal component respectively. Along the x-axis, 100 sampling points as a step are referred to 0.05chip. So, the difference between direct and multipath signal is 60 points, which is equivalent to 0.3chip. This verifies the accuracy of the delay differential identification of the TK operator.

The TK operator is used to obtain the number of multipath signals, and the signal parameters are estimated by MEDLL algorithm. When all the signal parameters are estimated, the Signal-to-Residual Ratio (SRR) is close to the signal to noise ratio (SNR) and shown in Equation (8). This equation is used to determine the estimated parameters accordingly.

$$SRR = \frac{\hat{a}_0^2}{\int_{\hat{\tau}_0-D/2}^{\hat{\tau}_0+D/2} \left\{ \text{Re} \left[R_0(\tau, \hat{\theta}_0) - \sum_{i=0}^M \hat{a}_i R_i(\tau, \hat{\tau}_i, \hat{\theta}_0, \hat{\theta}_i) \right] \right\}^2 d\tau} \geq k \quad (8)$$

where D is Correlator spacing; and k is threshold, usually taken as SNR.

The TK-MEDLL algorithm is shown in Figure 3 in terms of the flowchart, whereas the step by step work procedure is presented.

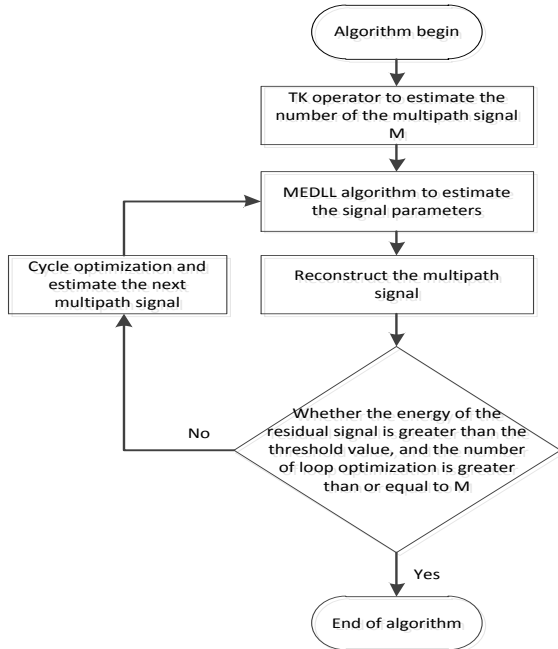

Figure 3: Flowchart of TK-MEDLL algorithm

- i. The correlation function expression is brought into the TK operator to estimate the numbers of multipath signals M ;
- ii. Estimate the phase here (using, the peak time t_{\max}) as shown in the Equation (9).

$$\left. \begin{aligned} \hat{\theta} &= a \tan\left(\frac{I_m(\mathbf{R}_i(t_{\max}))}{R_e(\mathbf{R}_i(t_{\max}))}\right); R_e(\mathbf{R}_i(t_{\max})) > 0 \\ \hat{\theta} &= a \tan\left(\frac{I_m(\mathbf{R}_i(t_{\max}))}{R_e(\mathbf{R}_i(t_{\max}))}\right) + \pi; R_e(\mathbf{R}_i(t_{\max})) > 0 \\ \hat{\theta} &= -\frac{\pi}{2}; R_e(\mathbf{R}_i(t_{\max})) = 0, I_m(\mathbf{R}_i(t_{\max})) < 0 \\ \hat{\theta} &= \frac{\pi}{2}; \text{others} \end{aligned} \right\} \quad (9)$$

- iii. The input signal is rotated to get the base-band signal, and the phase demodulation function is constructed as shown in the Equation (10)

$$D(\varepsilon) = \frac{R(\tau_1) - R(\tau_2)}{|R(\tau_1)| + |R(\tau_2)|} \quad (10)$$

Figure 4 describes the phase discrimination function curve. Here, we can see that the phase discrimination curve is a monotonic curve.

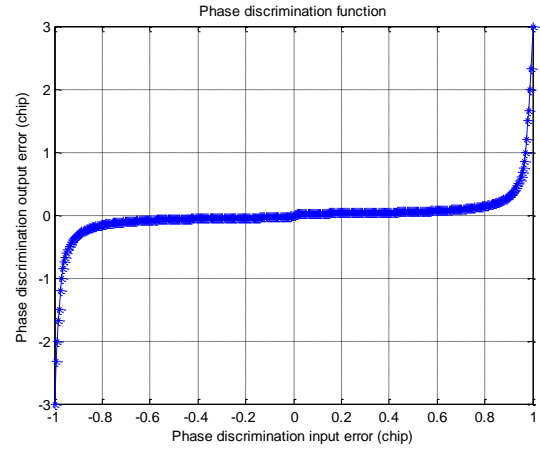

Figure 4: Normalized E-L phase discrimination curve

From Figure 5, we get:

$$\tau_1 = \tau_0 - \frac{\tau}{2} - \Delta\tau; \tau_2 = \tau_0 + \frac{\tau}{2} - \Delta\tau;$$

The correlation function of two points is brought into the phase discrimination function, as shown in the Equation (11).

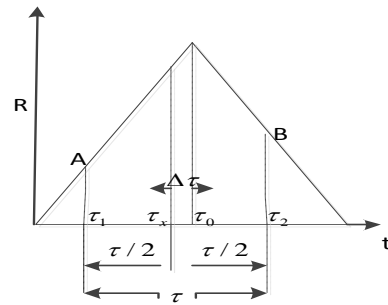

Figure 5: Signal rotation correlation function

$$D(\Delta\tau) = \frac{R\left(\tau_0 - \frac{\tau}{2} - \Delta\tau\right) - R\left(\tau_0 + \frac{\tau}{2} - \Delta\tau\right)}{\left| R\left(\tau_0 - \frac{\tau}{2} - \Delta\tau\right) \right| + \left| R\left(\tau_0 + \frac{\tau}{2} - \Delta\tau\right) \right|} \quad (11)$$

After taking the inverse of Equation (11), and then setting it equal to 0, we can $\Delta\tau$ obtain the time delay estimation.

- iv. After the time delay estimation is done, need to obtain midpoint moment τ_c , hence, the magnitude of the estimated value \hat{a} can be expressed as:

$$\hat{a} = \max(R) * \frac{R(\tau_c)}{R(\tau)}$$

III. SIMULATION AND ANALYSIS

A. Algorithm simulation

One direct and two multipath signal components are used for algorithm simulation using MATLAB software. The amplitude, time delay and phase delay of each signal are shown in Table 1. At the same time, Gauss white noise is added to make the signal to noise ratio of the composite signal around 60dB.

Table 1
Simulation Data

	Amplitude	Time-delay (chip)	Phase()
LOS	1	0	0
1 st multipath signal	0.4	0.3	
2 nd multipath signal	0.2	0.6	

A fatal weakness of the maximum likelihood estimate is that the parameter estimation of the next multipath signal depends on the current signal estimation, which easily causes error accumulation. In addition, in the process of estimation of multipath signals, due to the randomness of the multipath signals, the number of multipath is hard to determine. Usually, the conventional MEDLL algorithm gives a fixed number (two) of multipath, which is one LOS signal + a multipath signal. The simulation results of this method (MEDLL) are shown in Figure 6. According to the maximum likelihood estimation, all the parameters of each signal is also shown here.

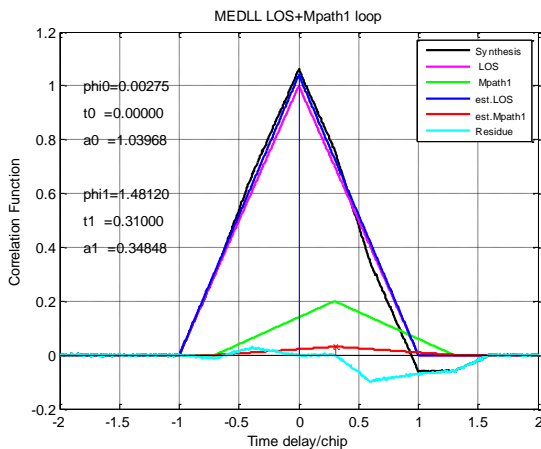

Figure 6: Parameter estimation of conventional MEDLL

In Figure 6, in the estimation of second multipath signals, the time delay estimation error is nearly 5%, the magnitude of the estimated deviation is around 12.67%. The estimated error of the LOS signal is accumulated with the first multipath signal, which makes the estimated parameters appear larger deviation. Besides, this method may make a false judgment on the actual number of multipath.

In proposed TK-MEDLL, TK operator is used to estimate the number of multipath in advance, and then the estimation of the parameters of each signal is combined with the residual estimation. The estimation accuracy of each signal is greatly improved, which can reduce the error accumulation to a certain extent as shown in the simulation results in Figure 7. It shows the amplitude estimation error of the 1st multipath signal component is increased by 0.0825%; whereas it is only 0.18% for the 2nd multipath signal component.

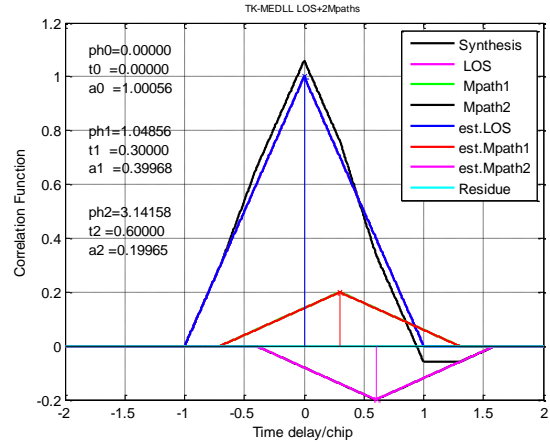

Figure 7: Parameter estimation of improved TK-MEDLL algorithm

In the real-life environment, due to the randomness of the multipath signals, the number of multipath is not predictable. In order to further verify the feasibility of the algorithm, we add a multipath signal. The considered signal parameters are as follows: $a = 0.5, \tau = 0.5, \theta = 2\pi/3$. The simulation results are shown in Figure 8.

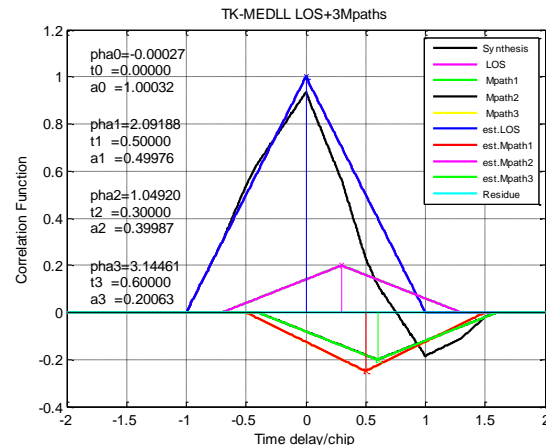

Figure 8: Parameter estimation of three multipath TK-MEDLL algorithm in 60dB environment

From Figure 8, the parameters of each signal can be estimated accurately. At the same time, through the estimation of residual signal energy and the use of TK operator, a number of multipath components can be identified precisely to overcome unnecessary erroneous judgment.

B. Analysis of Simulation Results

Based on the simulation results in Sub-Section A, the following conclusions can be drawn:

- i. By comparing Figures 6 and 7, it can be found that conventional MEDLL algorithm (i.e., by means of a

given multipath amount), it may lead to take improper decision along with large signal parameter estimation errors.

- ii. By comparing Figures 7 and 8, the difference between MEDLL and TK-MEDLL is the detection ability of various signals, followed by the approximation of the real signal. Results show that TK-MEDLL algorithm not only able to determine the number of multipath signal components but also enhances significantly the estimation accuracy of the signal parameters.
- iii. Figure 8 and 9 show that the experimental results of the algorithm at different SNR.

Through comparative study, conclusions are as follows: the signal parameters can be estimated accurately under the weak signal environment, but the estimation accuracy is reduced. It is verified that the signal to noise ratio has a certain influence on the estimation of signal parameters.

IV. CONCLUSION

In this paper, some problems and shortcomings of the MEDLL algorithm are presented, and a TK-MEDLL algorithm based on TK operator combined with residual estimation is proposed. The feasibility and superiority of the algorithm are verified by MATLAB simulation. The algorithm improves the accuracy of the signal parameter estimation, reduces the error accumulation, which is beneficial to eliminate the multipath signals from the comprehensive signal completely and restore the direct signal, and thus achieve the effect of multipath suppression. The TK-MEDLL optimization algorithm can directly estimate the number of multipath through the TK operator, to a certain extent, reduce the computational complexity, improve the real-time processing, and thus have a certain guiding significance for the project implementation.

ACKNOWLEDGMENT

This work has been supported by the National Natural Science Foundation of China (61362005, 61561016),

Guangxi and Sichuan science and technology project (AC16380014, 17ZDYF1495), the Guangxi Information Science Experimental Center, Key Laboratory of cognitive radio and information processing, Ministry of education, 2015, and director of the fund project (CRKL150113). Also, authors like to acknowledge the Guangxi Satellite Navigation and Location Sense Key Laboratory for providing equipment.

REFERENCES

- [1] Waldemar Kunysz. High Performance GPS Pinwheel Antenna_[C]// Proceedings of the Annual National Technical Meeting of the Institute of Navigation (ION-NTM' 2000), Salt Lake City, Utah, USA:ION, 2000: 2506- 2512.
- [2] ZHANG Jing Hong ,YE Tian Chun. XU Jian Hua, A multipath interference technology of an improved narrow band GPS receiver[J], Electron Devices2009,32(2).
- [3] L Garin, JM Rousseau, Enhanced Strobe Correlator Multipath Rejection for Code & Carrier, Proc. Of ION97, 1997.
- [4] B. Townsend and P. Fenton, A practical approach to the reduction of pseudo range multipath errors in a L1 GPS receiver, in Proc. ION GPS, Salt Lake City, UT, 1994: 143-148.
- [5] Fenton P C, Jones J. The theory and Performance of NovAtel Inc. cs Vision Correlator[C] Proceedings of the 18th International Technical Meeting of the Satellite Division of the Institute of Navigation. CA, US: IEEE, 2005:2178-2186.
- [6] LIU Ya Huan,TIAN Yu, LI Guo Tong ,GPS multipath estimation based on maximum likelihood estimation[J], Journal of Astronautics, 2009, 30(4):1466-1471.
- [7] R. D. J. Van Nee, J. Sieraveld, P. C.Fenton, and B. R. Townsend, The multipath estimating delay lock loop: approaching theoretical accuracy limits, Position Location and Navigation Symposium, pp.246-251, April 1994.
- [8] Kamran Rizwan Shamsi, Yang Dong Kai, Aamir Akhtar Siddiqui, Experimental Evaluation of Teager-Kaiser Discriminator under Multipath Environment for GPS Signal[C], 2011 6th IEEE Conference on Industrial Electronics and Applications,pp.991-995.
- [9] L. Garin, Dr. F. van Diggelen, and J. M. Rousseau, Strobe & Edge Correlator -Multipath Mitigation for Code, ION GPS-96, Kansas City, KS, September, Part 1, pp.657-664.
- [10] LIU Li Hong, LENG Wen, WANG An Guo, Arrival time estimation based on improved TK operator[J], Electronic Measurement Technology ,2014, 37(10): 50-54.)
- [11] ZHOU F,FUANG S J, Multipath signal suppression using Teager-Kaiser operator[J], Journal of University of Electronic Science and Technology of China, 2007, 36 (4) : 693-695.
- [12] XU Ning Bo, A multipath estimation method based on improved MEDLL algorithm[J], Radio communication technology, 2013 , 39(4): 11-13.