

# Comparative Study on the Performances of PV System with Various Combinations of Converter Topologies and PWM Types

Syahierah Eliya Binti Sabri, Muhamad Zahim Bin Sujod, Mohd Shawal Bin Jadin  
Sustainable Energy & Power Electronics Research (SuPER), Faculty of Electrical & Electronic Engineering  
Universiti Malaysia Pahang (UMP) 26600 Pekan, Pahang, Malaysia  
syahieraheliya@gmail.com

**Abstract**—Increasing demand for electricity generated from renewable energy sources forced power utility provider to develop more and larger power plant. In Malaysia, among renewable energy sources, photovoltaic (PV) is the most reliable. Hence, large-scale PV power plants have been developed and many more to be developed in the future. In case of large Grid-Connected PV (GCPV) power plant, the converter which is non-linear load will generate Total Harmonic Distortion (THD) into the electrical power system. Harmonic generated by the PV system may downgrade the quality of power grid and affect the reliability and safety. In addition, other main concerns in GCPV system are switching losses of the switching devices in the converter and the cost of the converter. These performances can be improved by the right choice of Pulse Width Modulation (PWM) type and converter topology. This paper will discuss which PWM type and converter topology should be chosen to produce the optimal performance based on THD, switching losses and cost. In general, the best combination is a two-level converter with continuous PWM (CPWM) where the cost is almost half compared to the three-level converter and having optimal value in the combined performance of THD and switching losses.

**Index Terms**—Converter Cost; Photovoltaic; Pulse Width Modulation; Switching Losses; Total Harmonic Distortion.

## I. INTRODUCTION

The growth of industrialization plus technology advancement results in increased energy demand. Thus the usages of fossil fuels get larger from year to year. Impacts from this situation are depletion of conventional fossil fuels, pollution and global warming and high cost involves. Photovoltaic (PV) system is one of the most popular renewable technologies used to replace the non-renewable sources. PV system is recognized as the direct conversion of sunlight energy to electrical energy by p-n junction semiconductor device.

Grid-connected PV (GCPV) or PV technology integrated with grid system is an interconnected network where electrical power from the generating power station is transmitted to substation through high voltage transmission lines then consumer received the electricity via distribution lines. In PV system, power electronics technology has a significant role [1] where the converter is the most important devices in this system to convert DC current to AC current before the output power transmitted to the grid. Figure 1 shows the typical configuration of GCPV system.

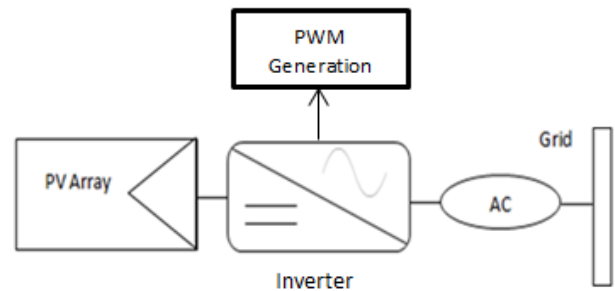

Figure 1: Typical GCPV system configuration

Power quality can be defined as the grid's ability to supply a clean and stable power supply. The main aim of the power system is to produce the noise-free sinusoidal wave shape and within voltage and frequency tolerance. However, some of the power quality issues such as harmonic distortion and switching losses will give negative impact to the system since the quality of the power grid will decrease plus the reliability and safety of electrical equipment will be affected [2, 3]. At the same time, these issues may lead to an increment of the cost of the converter in the system.

IEEE 519-1992 stated that harmonic distortion in power system is a sinusoidal component of a periodic wave that multiple of power system fundamental frequency. In power system, the main cause of harmonic is non-linear load [4] which can be the reasons overheating of all cables and equipment happen. Besides that, the intersection between the operating conditions of the grid and operation of the PV power converter also contribute to harmonic distortion [5]. According to IEEE Std 929-2000, the harmonic current requirement must not exceed 5% in grid-connected renewable energy generation systems [3, 5, 6]. The closer the waveform to sinusoidal, the smallest the THD [2]. THD can be defined as in Equation (1) [7].

$$\text{THD} = \sqrt{\sum_{h=2}^{50} \left(\frac{I_h}{I_1}\right)^2} \cdot 100 \quad (1)$$

where:  $I_h$  = rms current harmonic of harmonic order  $h$   
 $I_1$  = rms current of the fundamental component

Furthermore, low switching losses can produce less thermal stress of switching devices and the size of the heat sink in the compact power converter can be reduced. During

turning ON and turning OFF time, switching losses can occur. Equation (2) shows the equation for switching losses [8].

$$\text{Switching Losses} = V_{dc} \cdot I_t \cdot T_{switch} \quad (2)$$

where:  $I_t$  = instantaneous generated alternating current  
 $T_{switch}$  = switch time for a particular device

The main purpose of PWM technique is to control the power that is supplied to various types of electrical devices especially initial load such as AC/DC motors. On top of that, the objective of the PWM techniques is to acquire maximum fundamental component with minimum harmonic of the variable output voltage [9]. The right selections of PWM type effect the THD and switching losses of the converter [6]. The right combination of the PWM type and converter topology can either minimize THD [4], switching losses and cost. Cost can be reduced for the reason that the number of the switching device in the converter is less, yet the performance of the converter can be maintained optimally.

## II. CONVERTER TOPOLOGIES

The main function of the converter is to convert DC current to AC current. Basically, in PV system, the converter is integrated between photovoltaic cell and AC network. Nowadays, most of the load applied AC current and converter become one of the important devices in power system. In steady state, PV converter must have the function of regulating frequency and voltage [10].

The high performance of multilevel converter plus low harmonics distortion has made the multilevel converter as the main choice for the industrial and electric power systems [4, 11]. There are various types of multi-level converters and one of the types that will be discussed is three-level Neutral-Point-Clamped (NPC) converter. In this paper, the performances of two-level and three-level NPC converters based on previous researchers are listed to be compared.

The two-level converter is not applicable for high voltage applications because higher voltage levels are not produced and opposite to three-level converter where higher voltage levels are produced. Figure 2(a) shows the two-level converter and Figure 2(b) shows the three-level NPC converter [12]. Referring to the figures, the two-level converter has 6 switching devices with simple control scheme while the three-level NPC converter has 12 switching devices with more complex control scheme.

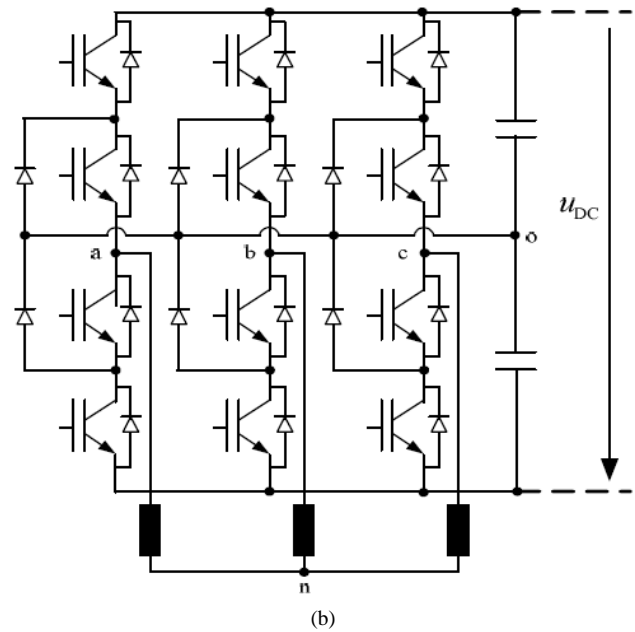
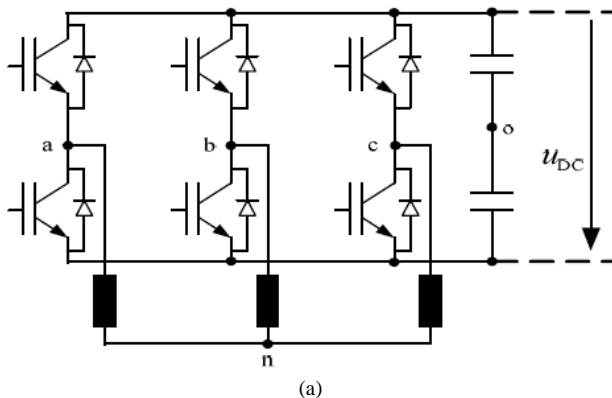

Figure 2: Converter topologies [12]; (a) Two-level converter, (b) Three-level NPC converter

## III. PULSE WIDTH MODULATION

Pulse Width Modulation (PWM) is a fancy term used to describe a type of digital signal which has the ability to control voltage and frequency at one stage. Furthermore, harmonic distortion and switching losses can be minimized with PWM technique [13].

This technique can maximize the system gain at high modulating index values and the linear range of system operation. PWM is used for controlling the amplitude of digital signals in order to control devices and applications requiring power or electricity. Moreover, it also will act as the signal pulse for the converter [11].

Next, the general theory of PWM technology will be explained in two main aspects which are pulses involve and the main principle of PWM technique. Firstly, there are two groups of pulses involves the inertial link input as shown in Figure 3. The pulses are two different waveforms known as a modulated waveform and carrier waveform. Typical PWM controller receives three modulated waveform and each of the modulated signals is 120° out of phase with other two modulated signal and triangle carrier signal is used [2]. Both of the pulses have same impulse area and also same effectiveness.

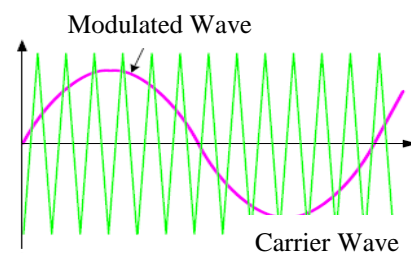

Figure 3: Two groups of pulses involves in PWM

Desired frequency three phase modulated signals are compared with high-frequency triangular carrier signal [4, 14]. As the result, the process will generate a logical signal

which later will be the switching instant of converter [7]. Secondly, the main principle of PWM technique is ON/OFF control on semiconductor switching component for the output with generated pulses with the same amplitude but different width [9].

Modulation index ( $m_i$ ) can be defined as the ratio of peak modulated waveform ( $V_m$ ) and carrier waveform ( $V_C$ ) magnitude. The modulation index can be expressed in this equation [2]:

$$m_i = \frac{V_m}{V_C} \quad (3)$$

Normally the modulation index preferred in PWM techniques is  $0 < m_i < 1$  where the carrier waveform has higher peak magnitude than modulated magnitude [11, 15]. The linear relationship between input and PWM output voltage is maintained and good quality output voltage produced [14]. Meanwhile, over modulation can occur when  $m_i > 1$  or when modulated waveform peak magnitude is higher than carrier waveform peak magnitude. Over modulation is not preferred since linear mode cannot be kept and increment fundamental voltage magnitude will decrease the quality of output waveform [8].

Generally, Continuous PWM (CPWM) and Discontinuous PWM (DPWM) are two types of PWM. One of the PWM types is called continuous PWM because of its continuous signal throughout the modulating signal cycle. The other type which is discontinuous PWM is purposely set equal to peak carrier signal so that switching does not occur at least 40% carrier signal cycles. One phase switches are not switching, while the other two phases remain sinusoidal line to line voltage. Figure 4 shows the differences between CPWM and DPWM output signal [7].

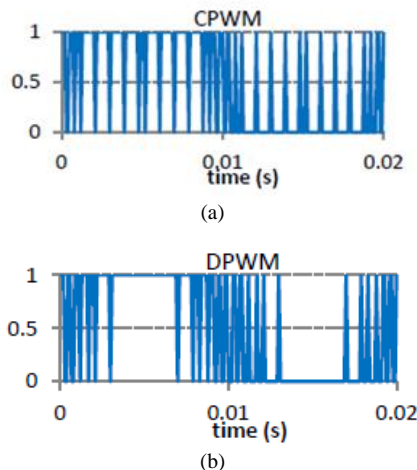

Figure 4: Output signal of CPWM and DPWM [16] (a) CPWM output signal, (b) DPWM output signal.

Some of the examples of CPWM and DPWM types are shown in Figure 5. Examples of CPWM types are Sinusoidal PWM (SPWM) and Third Harmonic Injected PWM (THIPWM), while DPWM types are DPWM0, DPWM1, DPWM2 and DPWM3 [16].

From all of the PWM types listed, the basis of the PWM is referred to a CPWM type which is SPWM. It is the most popular in the industry for reducing harmonic purpose [14] and simple method applied where sine-triangle wave comparison are method applied in this technique [11]. Figure

3 is the example of a sine-triangle wave that involves this technique. The variable duty cycle of the output waveform is the result of the different crossing position. Then, level switching edge will be produced after sine wave intersects with triangle wave [4].

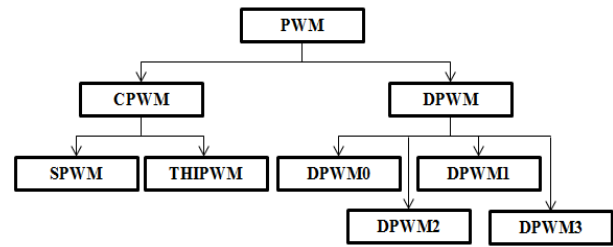
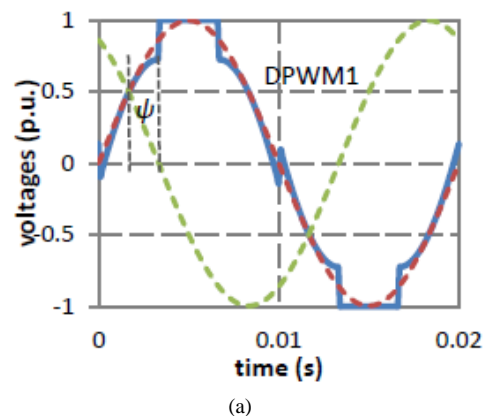

Figure 5: Type of PWM which is CPWM and DPWM and example of each of CPWM and DPWM

In addition to SPWM, a third harmonic signal whose frequency is three times that of the fundamental frequency is injected into the sinusoidal modulated wave and saddle-like modulated wave will be produced. The modified modulating signal is compared with triangle carrier wave. This CPWM technique is called THIPWM and it is optimized PWM method with advantage such as brings down peak magnitude of resultant modulating waveform [15].

To conclude about CPWM, SPWM is the only PWM type that has no third harmonic signal injected in the fundamental frequency of the modulating frequency. Mixed third-harmonic in the PWM techniques can 15.5% improve the converter output voltage compared to SPWM and at the same time able to give better THD performance [7].

DWPM types are including DPWM0, DPWM1, DPWM2 and DPWM3. In this paper, DPWM1 and DPWM2 will be explaining further. Both of the DPWM types mentioned are the techniques where both are generated by adding third harmonic signal to each of the modulating signals. Figure 6 shows the modulating signal of DPWM1 and DPWM2 [7]. The dotted line is the sinusoidal modulating wave, while the blue colour is the modulated signal after mixed with a third harmonic signal that three times than the fundamental frequency. According to [8], the instantaneous magnitude of the third harmonic signal of DPWM1 and DPWM2 are based on the difference between peak carrier signal value with the instantaneous maximum modulating signal magnitude and instantaneous maximum shifted signal magnitude respectively.



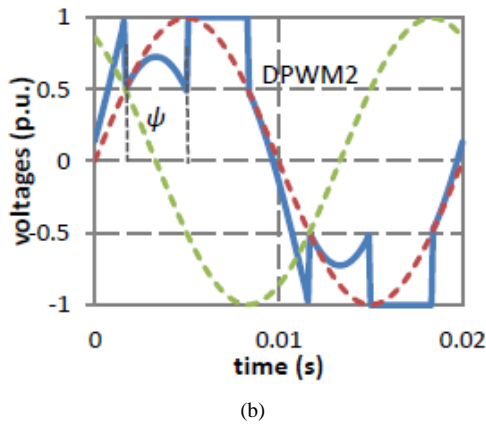

Figure 6: Modulating signal of DPWM1 and DPWM2 [7]; (a) Modulating signal of DPWM1, (b) Modulating signal of DPWM2

IV. PERFORMANCE INDICATOR

The performance observations in this paper are on the THD, switching losses and cost of the converter. Apart from that, the performance of the converter topology combined with PWM types also will be discussed.

In term of the output voltage, two-level converter generates two magnitude output voltage levels meanwhile three-level converter generates three voltage levels with respect to the negative terminal of the capacitor. As stated before, the THD is reduced if the waveform is close to sinusoidal.

Harmonics distortion can be reduced when the number of converter voltage levels increase since converter output waveform will nearer to sinusoidal when the converter voltage levels increase [14]. Thus, three-level NPC converter can produce low THD in output voltage compared to the two-level converter.

The number of diodes increases according to the level of the output voltage of NPC or Diode Clamped Converter [11]. More switching stresses on the device if the two-level converter is used, while using three-level NPC converter, it is able to reduce the switching stresses on devices.

The main performance characteristics that will be compared between CPWM and DPWM are the harmonic distortion and switching losses. At low modulation index, the harmonic distortion for CPWM is low [6]. Meanwhile, greater harmonic distortion occurs when low modulation DPWM is used. This is because harmonic is produced when the pulses are being modified when the PWM controller modifies the modulating signal as a function of the third harmonic signal on per carrier cycle.

Figure 7 shows a graph that illustrating the harmonic distortion against modulation index for each of the PWM types [8]. From the graph, when the modulation index is from 0 until approximately 0.5, DWPM signals have higher THD than CWPM signals. After the modulation index passes 0.5 and above, the CPWM signals show increment in THD.

Clearly, it is known that CPWM signal cause less harmonic distortion compared to DPWM at low modulation index but vice versa when the modulation index is greater. For all CPWM types, the switching losses are same and independent of all load current phase angle while the switching losses for DPWM are influenced by modulation types and load power factor [7] and able to minimize converter switching losses [17]. In [17] stated that average switching losses for DWPM are 33% less compared to SPWM.

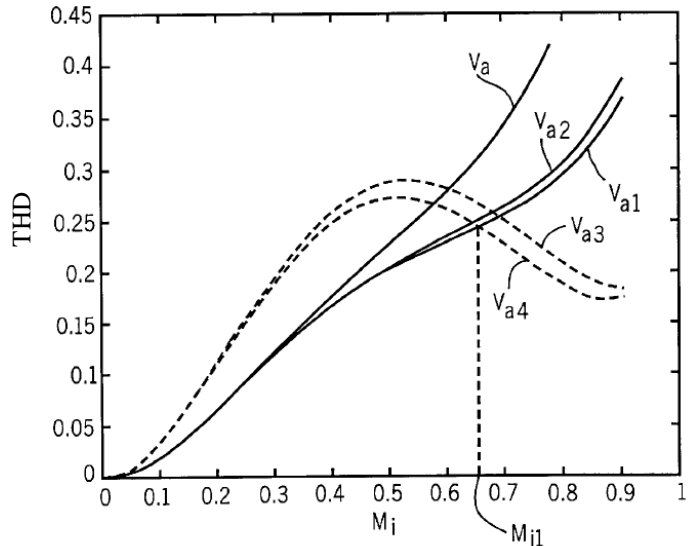

Figure 7: Graph of THD against modulation index  $m_i$  for CPWM and DPWM signals ( $V_a$  = SPWM,  $V_{a1}$  = SVPWM,  $V_{a2}$  = THIPWM,  $V_{a3}$  = DPWM1,  $V_{a4}$  = DWPM2) [8]

To sum up, three-level NPC converter has better performance than two-level converter but many utility companies do not prefer to use it because of the higher cost [12] and need larger space due to the complexity of the scheme. Three-level NPC converter will cost 50% more than two-level converter in view of the fact that the number of the diode in three-level NPC converter is double than the number of the diode in the two-level converter.

V. CONCLUSION

A converter cannot produce ideal sinusoidal voltage waveform. Thus, a suitable type of PWM aims to improve power quality by reducing harmonic in a power system. Each of the PWM types has its own merit and drawback in terms of harmonic distortion and switching losses. The good combination of the converter topology and PWM type can help to reduce these problems. In PV system, a converter is one of the most important Balances of System (BOS) to convert the DC current produce to AC current before transferred to the network. Based on [2-5] and discussion in the previous section, the harmonic distortion (THD) for low modulation index and Switching Losses (SL) performance of two-level and three-level NPC converter with PWM type is shown as in Table 1.

Table 1  
Harmonic Distortion (THD) and Switching Losses (SL) Performance of Two-Level and Three-Level NPC Converter With PWM Type

Converter Types	CPWM	DPWM	Scheme	Cost
Two-level Converter	THD: 2 SL: 2	THD: 1 SL: 3	Simple	Low
Three-level NPC Converter	THD: 3 SL: 1	THD: 2 SL: 2	Complex	High

Performance indicator: 1 (Poor), 2 (Moderate), 3 (Good)

The two-level converter may produce high THD in output voltage and has more switching losses compared to three-level NPC converter even the cost for the three-level NPC converter are higher compared to the two-level converter due to higher switching devices and complex control scheme.

Refer to the Table 1, the performance of each of the converter with different types of PWM type used are different.

The combination of three-level NPC converter with CPWM produces a good result with less THD but high in SL and vice versa for a combination of the two-level converter with DPWM. For balance result between THD and SL, the combination of the two-level converter with CPWM and three-level NPC converter with DPWM can be considered. Both of the combinations are moderate in THD and SL. When considering the complexity of switching scheme and converter cost, the combination of the two-level converter with CPWM is more preferable.

#### ACKNOWLEDGMENT

This research is supported by Ministry of Higher Education Malaysia under Fundamental Research Grant Scheme (RDU 150125). The authors would also like to thank the Faculty of Electrical & Electronics Engineering University Malaysia Pahang for providing the facilities to conduct this research.

#### REFERENCES

- [1] N. Kumar, T. K. Saha, J. Dey, and J. C. Barman, "Modelling, control, and performance study of cascaded inverter based grid connected PV system," in *IREC2015 The Sixth International Renewable Energy Congress*, 2015, pp. 1–6.
- [2] S. Kharjule, "Voltage source inverter," in *2015 International Conference on Energy Systems and Applications*, 2015, pp. 537–542.
- [3] X. Zhao and S. Liu, "A Research of Harmonics for Multiple PV Inverters in Grid-Connected," in *2012 Asia-Pacific Power and Energy Engineering Conference*, 2012, pp. 1–4.
- [4] P. Mohnaty and S. Sahoo, "Analysis of Two-level and Three-level Inverter," Thesis, National Institute of Technology, Rourkela Rourkela.
- [5] A. Abdool and K. Alwannan, "Current harmonic generation of a modeled and simulated single phase grid connected PWM current controlled photovoltaic inverter," in *2014 First International Conference on Green Energy ICGE*, pp. 89–95.
- [6] S. Oh and M. Sunwoo, "Variable structure PWM controller for high efficient PV inverters," in *2008 IEEE International Conference on Sustainable Energy Technologies*, 2008, pp. 933–938.
- [7] S. M. Zahim and I. Erlich, "Control of DFIG based Wind Turbine Converter using Continuous and Discontinuous PWM: A Comparative Study," *IFAC Proc. Vol.*, vol. 45, no. 21, pp. 542–547, Jan. 2012.
- [8] A. M. Hava and R. J. Kerkman, "Generalized discontinuous pulse width modulator," US6023417 A, 08-Feb-2000.
- [9] S. K. Singh, H. Kumar, K. Singh, and A. Patel, "A Survey and Study of Different Types of PWM Techniques Used in Induction Motor Drive," *Int. J. Eng. Sci. Adv. Technol.*, vol. 4, no. 1, p. 5.
- [10] M. Liu, J. Huang, Y. Dong, and H. Li, "Steady-state control performance modeling and simulation analysis for grid-connected PV inverter," in *2016 China International Conference on Electricity Distribution (CICED)*, 2016, pp. 1–4.
- [11] W. Subsingha, "A Comparative Study of Sinusoidal PWM and Third Harmonic Injected PWM Reference Signal on Five Level Diode Clamp Inverter," *Energy Procedia*, vol. 89, pp. 137–148, Jun. 2016.
- [12] M. Z. Sujod and I. Erlich, "Harmonics and common mode voltage in a DFIG with two-level and three-level NPC converter using standard PWM techniques," in *IECON 2013 - 39th Annual Conference of the IEEE Industrial Electronics Society*, 2013, pp. 1650–1655.
- [13] A.A. M. Ruban, N. Hemavathi, and N. Rajeswari, "Real time Harmonic Elimination PWM control for Voltage Source Inverters," in *IEEE-International Conference On Advances In Engineering, Science And Management*, 2012, pp. 479–484.
- [14] D. Prajapati, V. Ravindran, J. Sutaria, and P. Patel, "A Comparative Study of Three Phase 2-Level VSI with 3-Level and 5-Level Diode Clamped Multilevel Inverter," *Int. J. Emerg. Technol. Adv. Eng.*, vol. 4, no. 4, p. 6, Apr. 2014.
- [15] Infineon Technologies AG, "Different PWM Waveforms Generation for 3-Phase AC Induction Motor with XC164CS," 04-Aug-2006.
- [16] M. Z. Sujod, "Advanced Converter Control Techniques for Improving the Performance of DFIG based Wind Turbines," Universität Duisburg-Essen.
- [17] L. Asiminoaei, P. Rodriguez, and F. Blaabjerg, "Application of Discontinuous PWM modulation in Active Power Filters," *IEEE Trans. Power Electron.*, vol. 23, no. 4, pp. 1692–1706, Jul. 2008.