

Design and Simulation of a Zero Crossing VSC Based Phase Synchronous Inverter for Microgrid System

Tawfikur Rahman¹, Mohammad Kamrul Hasan², Musse Mohamud Ahmad² and AKM Zakir Hossain¹

¹*Department of Electrical and Computer Engineering,*

International Islamic University Malaysia, Kuala Lumpur, 53100, Malaysia.

²*Department of Electrical and Electronics Engineering, University Malaysia Sarawak (UNIMAS).*

tawfikurr@gmail.com

Abstract—A microgrid is a system which consists of the transmission line and loads capable of operating in parallel with the national grid and distributed power sources such as power generation, storage and demand management. However, to connect the wind, solar and electrostatic power generation system together with microgrid, a phase synchronisation issue arises. For the electrostatic system, generated DC voltage needs to be converted into AC to connect with the transformer-less microgrid system. This process inherently produces very low output current and also degrades the phase synchronization of the system. To counter these issues, a zero-crossing voltage source controller based phase synchronous inverter system has been designed and implemented in this paper. In addition, an active LCL filter has been designed to reduce the high harmonic distortion. Moreover, to verify the result, MATLAB2014a software has been used. In this design, input DC voltage of 10kV, switching frequency of 1.65 kHz, grid frequency of 50Hz and balanced grid loads of star configuration (00, 1200, and 2400 degree) are considered. The simulated result has shown that inverter inversion efficiency is 96.8% and phase angle error is only 3.50 degrees.

Index Terms—Microgrid; LCL Filter; VSC; Zero Crossing; PSI.

I. INTRODUCTION

Phase synchronous inverter (PSI) is an electronic power switching circuit that can convert input DC to output AC voltage with the same phase and frequency [1]. Generally, inverter can be a small quantity of output power. Several losses in power inverting development are not accessible whereas powering to the load circuit. There are several problems such as power losses in inverter circuit due to the high switching frequency, switching controller also adds some loss in the inverter [2]. Meanwhile, an inverter is also an electronic device that transforms input voltage which is DC or AC into an output voltage which is AC or DC type. The purpose of DC to AC synchronous electrical inverter will be needed DC input power from a different source such as solar, wind and electrostatic generator converted it to AC output power [3]. As, an electrical power inverter gets DC input voltage provide from (two standard solar panels which are around 70V, 12V, 24V, 100V, 140V, 200V, and 500V RE source like solar power, wind power and battery then electrical inverter transforms it to 220V, 240V or 440V AC with a required frequency of 60Hz or 50Hz [5] [6]. On the other hand, the minimum and maximum speed of the electrostatic generator is produced high static DC voltage like

4kV to 1000kV_{dc}, but it has generated very low ampere current (mA) [7]. These DC to AC power inverters are wide used for microgrid applications like distribution system. Newly, the power inverters square measure is taking part in a crucial part within the numerous electrostatic generator applications such as these are employed for microgrid connection of sustainable energy systems [8]. Additionally, to the current, the control methods used in the power inverters also are just like those in DC to AC converters. Each voltage imbalance method and current imbalance method control have used in sensible applications.

DC to AC power inverters sometimes controls voltage source PWM generator. The PWM is also be a terribly increase, and helpful technique within that size of the gate pulses are controlled through different devices. However, the PWM electrical synchronous inverter has employed to interruption the output AC voltage of the electrical synchronous inverter by the regarded voltage regardless of each load. Within a straight inverter output voltage can be modifications allowing to the modifications within each load. Toward eliminate during this impact of the altering load, the PWM electrical synchronous inverter detailed the output power by modifying the size of the pulses and therefore the output power be contingent on the switching logic frequency and pulse size that is familiar per the significance of the load coupled to the output therefore on give persistent rated output [9].

The output lowpass filter is very important in power inversion systems to decrease the higher frequency harmonic distortion, adjustment the phase angle and improve the inverter conversion efficiency. There are many types of filter using in the microgrid system but LCL lowpass filter has specially used in the high voltage three phase microgrid systems. It's also improved the phase, and protected the inverter switches. In case of low power microgrid systems, a lowpass LC filter is employed because it's cheap, simple, reliable and need less power supply. On the other hand, LCL filter is more complexed in low power microgrid systems but more dependable for phase synchronization between microgrid and inverter phase [10].

Zero crossing is an electric component with a voltage is driven oscillator that can adjust to the match the frequency of the phase of a grid signal. Zero crossing based voltage source controller circuit is used to less switching loss for phase synchronization with frequency, phase, current, voltage control. It has a feedback component which has considered

to allow a circuit to match the frequency of the phase of it's on the clock with an outside judgement signal. At the same time regulates the phase angle of the oscillator's signal of the clock for the same frequency and phase of the reference signal [11].

Microgrid systems are more complexed with the combine of load feeders. Two types of load feeders are used in simple microgrid system such non-sensitive-load and sensitive-load feeder. If the power quality problem and any kind disturbance have occurred in the microgrid system, a non-sensitive-load feeder is utilized to shut down and power by pass the main grid feeder. However, the energy in grid line should be supplied by the sensitive-load feeders; therefore, in order to fulfil the inner feeder load, each feeder which are connected with the system should include a minimum number of micro sources [11].

II. ZERO CROSSING BASED PS INVERTER

The functional block diagram of zero-crossing voltage source controller based PSI system which consists of input DC source, IGBT/Diode switches, zero crossing circuit and voltage source controller is showed in Figure 1. The input DC voltage of the inverter is taken from the electrostatic generator to convert into microgrid voltage (AC voltage). For operating the IGBT/Diode switches, gate pulse is generated by a voltage controlled source to shrink the switching effect and convert the AC microgrid voltage [13]. Since minimal current is produced by electrostatic generator, for increasing the output current of the system, series connection of IGBT switches is employed. The set of switches connected in series is named as module. Each module is constructed by 10 IGBT switches. Moreover, two modules construct the half phase inverter. The combination of three half phase inverters constructs the final design of the three-phase inverter circuit. The two input sources of $+10kV_{dc}$ and $-10kV_{dc}$, one mutual point of 0, ground resistance R_g of 1Ω , V_A , V_B and V_C of the three output phase terminals and six IGBT modules with six gate pulses as G_1, G_2, G_3, G_4, G_5 and G_6 are included in the circuit design. There are two parameters of each IGBTs which are internal $R_{on}=1 \times 10^{-3}\Omega$ and snubber resistance $R_s=1 \times 1005\Omega$. Figure 2 shows the construction and operation of three phase microgrid inverter circuit. The three-phase inverter consists of two series connected modules and three output terminals. To ensure protection of the inverter circuit from surge voltage, a reverse biased flywheel diode is connected to each IGBT [7].

The diodes provide the load current though an alternative path by turning 'OFF' the modules. The connection of the load is applied between two modules at the midpoints marked as '0' and the junction point marked as 'A'. On the basis of the logical condition of the gate pulses, module 1 and 2 stay at ON and OFF state. For a certain time, module1 is ON and module 2 is 'OFF' so that the output square wave voltage with a constant duty cycle is maintained.

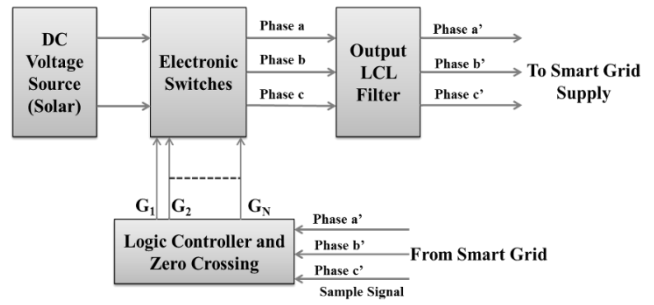
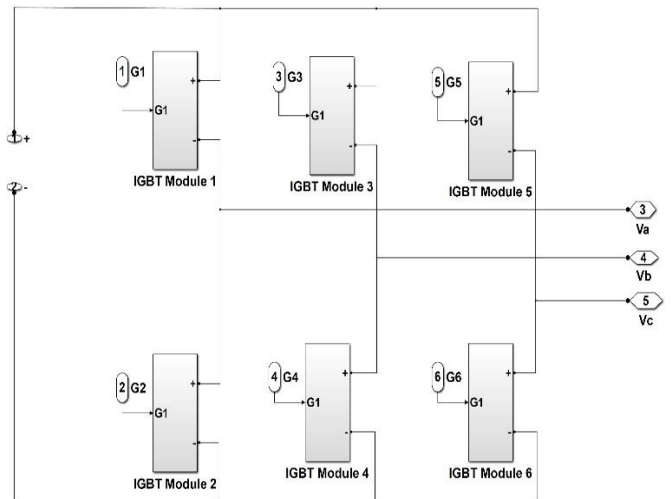
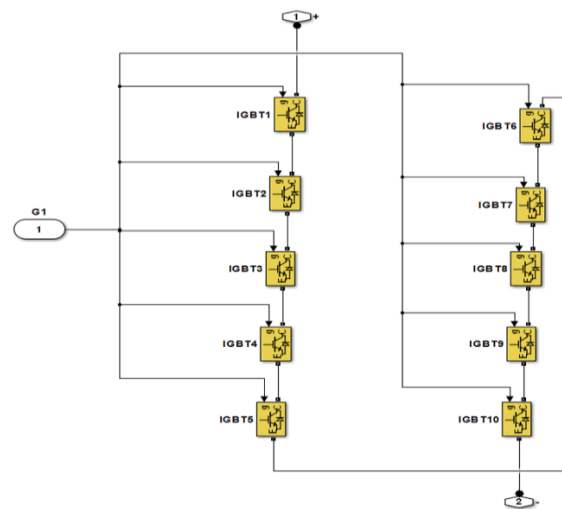

Figure 1: General block diagram for phase synchronous inverter

At module 1 'ON' state, the load voltage V_{AO} with magnitude of $+10kV_{dc}$ is obtained at module 2 'ON' state the magnitude is reversed to $-10kV_{dc}$. A complementary turning manner is applied at the inverting terminal for the two modules. The modules should not be 'OFF' or 'ON' at simultaneous condition for the general load. While simultaneously turning 'ON' both switches, short circuit will be occurred across the DC supply as well as rapid rise of switch currents will be caused. Consequently, switching loss is not found in the IGBT switches. Moreover, the circuit efficiency is improved [4] [11].



(a)



(b)

Figure 2: General block diagram for (a) IGBT module and (b) IGBT/Diode

III. DESIGN OF A VOLTAGE SOURCE CONTROLLER

Figure 3 shows the operational block diagram of the designed voltage source controller which is simulated by MATLAB2014a/Simulink/simpower block. The controller consists of Vdc regulator, current regulators with feedforward, voltage source Vac regulator, U_{abc} -reference generator and three phase PWM generators are corresponding. It is used eight switching logic states for operates the six modules in a circle to generate a three-phase output voltage. Each phase is triggered at 120° phase apart such as 0° , 120° and 240° respectively [4]. A controller has used for two level carriers based topology. U_{ref} of the reference signal is sampled and paralleled by a symmetrical triangle carrier. In addition, the carrier signal is less than the reference signal of U_{ref} , the pulse signal for '0' is low switching, and '1' is the higher of the upper switching. In this design, V_{ref} is needed to create pulse signals [1]. These pulse signals are inside generated by phase-shifting the original reference signal by 120° degrees [5].

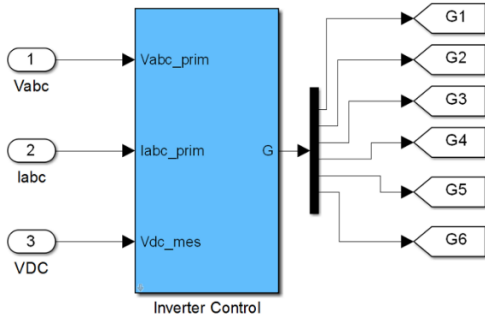
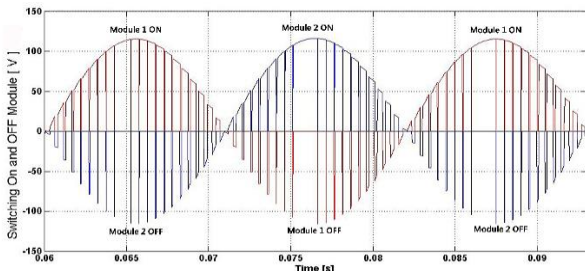

Figure 3: PWM controller block diagram

For a three-phase system, three reference signals are essential to produce the six signal pulses. The reference signals are also internally generated by the PWM generator. In this case, a voltage output frequency, phase and a modulation index are specified. In this design, some parameters are considered for the control circuits [6].

Figure 4 shows the gate current I_g of the IGBT module for three phase PSI. The generation of each reference signal is done here by couple of pulse signals. In case of a half-phase IGBT module, the first reference signal is compulsory to provide the pair of pulses of the first arm. A phase shift of 90° to the original signal is applied in order to internally generate the first reference signal. The reference signal is acquired by PWM circuit. To operate the six modules, eight switching logic states are used by PWM based. Three phases are triggered with shifts of 120° apart like 0° , 120° and 240° .



(a)

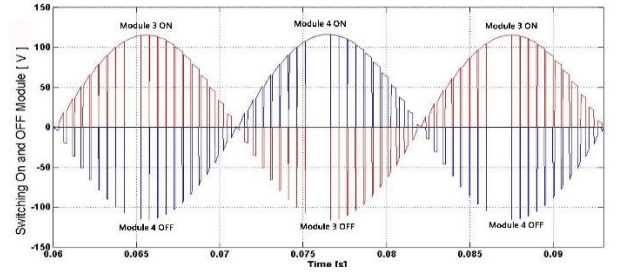

(b)

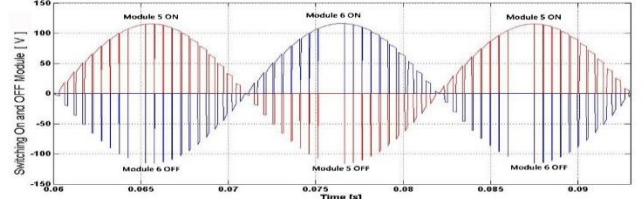

(c)

Figure 4: Switching signal for (a) module 1 and 2, (b) module 3 and 4 and module 5 and 6

IV. OUTPUT LCL FILTER DESIGN

A simple low-pass filter with three poles is mostly utilized to minimize the switching ripple current and phase shift which may lead to oscillations. For the reduction of DC ripple current and higher harmonic distortion, LCL filter has been used in the design as shown in Figure 4. The selection of an inductor is the preliminary stage. The inductor ripple current rating should be same to the maximum output current of the PSI at saturated mode. The output ripple current is improved during the reduction of inductance in saturated modes of the PSI.

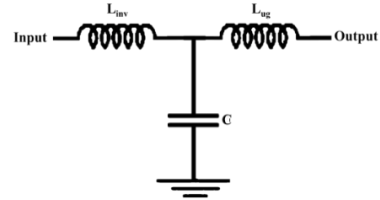

Figure 4: Single phase LCL filter circuit

The large size of inductor used to counteract at high voltage drops by load transients requires a large capacitor. The secondary stage is to choose a capacitor. The capacitor must be selected with high value by considering size, voltage ratings, dynamic response and price [10]. For achieving the expected damping ratio, components of the filter are calculated by the Equation (2) and (3):

$$\frac{V_{\max \text{ ripple}}}{V_{Oac}} = \frac{X_c}{X_c + X_l} \quad (1)$$

where: $V_{\max \text{ ripple}}$ = Maximum output ripple
 V_{Oac} = Listed output ripple

$$X_c = \frac{1}{2 \times \pi \times f \times L} \quad (2)$$

$$X_l = 2 \times \pi \times f \times c \quad (3)$$

where, f is Hz of the switching frequency, C is F of capacitance and L is H of inductance.

V. DESIGN OF A SYNCHRONOUS SWITCHING TOPOLOGY

Zero crossing method is used to detect the signal between inverter input voltage and microgrid output voltage as shown in Figure 5. From the microgrid, three reference sample voltage V_a' , V_b' and V_c' are taken for the sampling circuit. This sampling circuit is employed two type of voltage such as DC and sample voltage [11]. The DC voltage is used to operate the sub electrical circuit, but, the sampling voltage such as S_a , S_b and S_c pass through the zero-crossing circuit. The primary job of the zero-crossing circuit is to identify the zero-crossing point and to make the zero-crossing sample Z_a , Z_b and Z_c . Electronic switching pulse generator utilizes these three zero crossing sample to generate six pulses such as G_1 , G_2 , G_3 , G_4 , G_5 and G_6 . Zero crossing sensors are utilized to identify the phase angle.

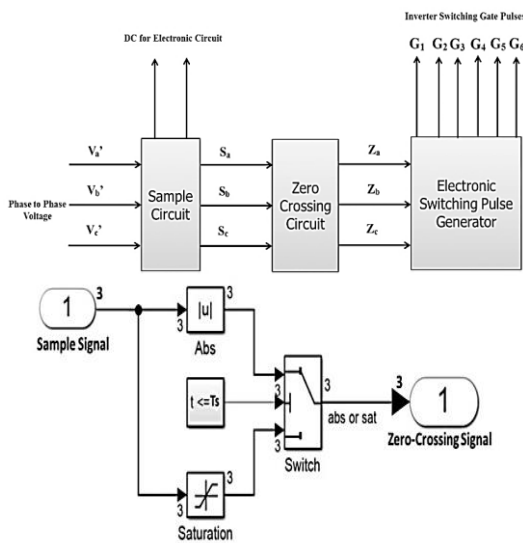

Figure 5: Zero Crossing with switching controller block diagram and Matlab circuit

VI. RESULTS AND DISCUSSION

This design has been simulated by using MATLAB2014a /Simulink/simpower software. The PSI systems are used of the $\pm 5kV_{dc}$ input voltage to convert almost $10kV_p$ of squire wave voltage. To generate voltage source controller circuits, the optimum switching frequency is $1.65kHz$, $50Hz$ of the fundamental frequency, $33Hz$ of the cut-off frequency, sampling time $0.1s$ and the sampling per cycle is 1620 . Figure 6 shows the zero-crossing voltage source PSI output voltage without filtering condition. Without filtering condition is $V_{ab}=V_{bc}=V_{ca}=10kV_p$ of the PSI output voltage, and the three-phase voltage is around $V_{abc}=5kV_p$, respectively.

At the same time, without filtering condition inverter output phase-to-phase current is around $\pm 120 A$ because IGBT module are connected in series as shown in Figure 7. Thus, switching loss is reduced and increased the inverter output current because the electrostatic generator is generated mA of current which is around $0.05mA$.

Figure 8 shows zero crossing voltage source controller based microgrid output voltage with filtering condition. It has been observed that microgrid output phase to phase voltage is $16kVA$, fundamental frequency $50Hz$ and 100Ω of the microgrid resistive load, respectively. The inverter output is connected to the microgrid side the phase-to-phase current is around $\pm 78 A$. as a result, the phase is synchronized every cut-off point and very low harmonic.

Figure 9 shows that the phase synchronization between inverter phase and microgrid reference phase angle waveform without filtering condition. According to the figure, V_a, V_b and V_c are the inverter output voltage with filtering condition while, V_a', V_b' and V_c' are the microgrid reference voltage. The simulated result has presented that synchronization is almost was done. The phase angles are $V_{ab}-V_{bc}$ of 89.2° , $V_{bc}-V_{ca}$ of 201.2° , $V_{ca}-V_{ab}$ of 37.3° . With filtering case, the phase angles are 123.8° , 243.3° and 3.5° , respectively. As a result, the phase angle is increased while the harmonic distension is also increased. When the signal passed through the filter to shift the phase, but harmonic is reduced.

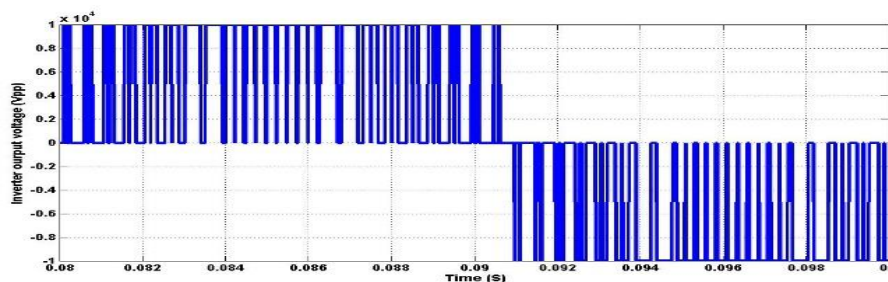

(a)

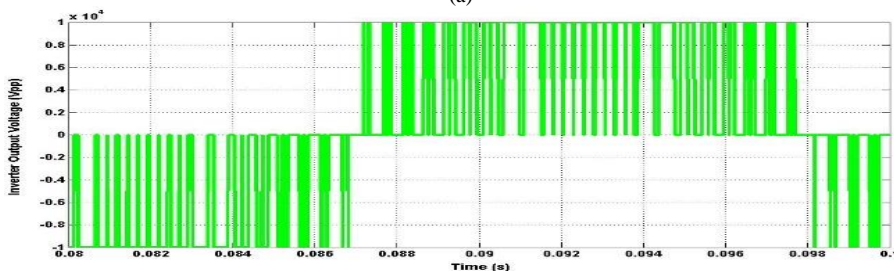

(b)

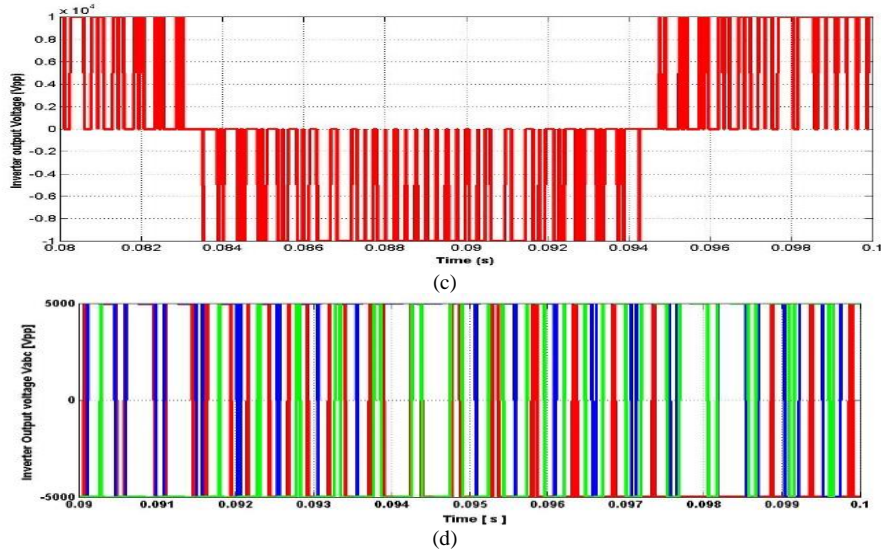

Figure 6: Inverter output voltage waveform for (a) V_{ab} , (b) V_{bc} , (c) V_{ca} and (d) V_{abc} without filtering

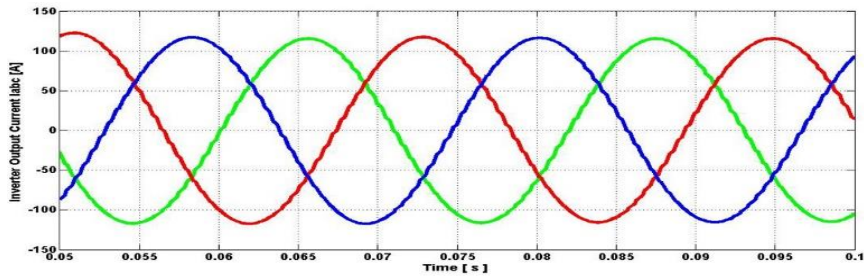

Figure 7: The inverter output voltage waveform without filtering

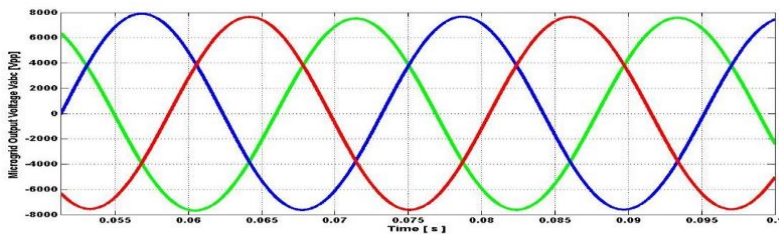

Figure 8: Utility grid voltage waveform with filter

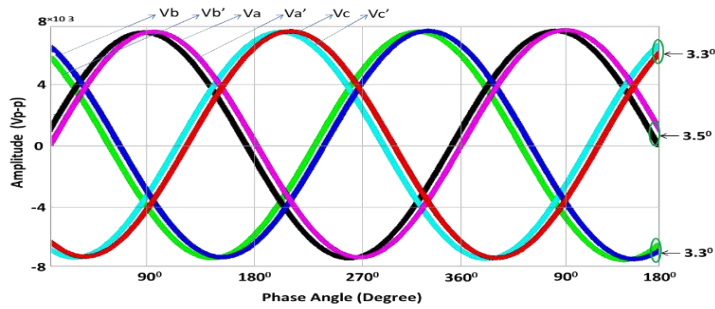

Figure 9: Synchronous waveform of a PSI and smart grid phase

Table 1
Comparison between proposed system and other works

Paper	Design (Number Switches)	Switching Frequency (kHz)	Modulation Index (M)	Input Voltage (V)	Output Voltage (V)	Phase Angle (Degree)
Chen et al., 2017	Three (Six)	2	0.8	750	622.3	N/A
Bal et al., 2016	Three (Six)	70	0.5	48	380	N/A
Proposed	Three (Six)	1.65	0.95	10k	16k	3.5°

Table 1 shows the comparison between proposed PS inverter system and other existing works. From Table 1, it can be seen that the proposed PSI system's phase angle is 3.3° but authors did not consider revealing this information. The main problem of the synchronization process is, when phase angle

is reduced, the THD is also increases.

VII. CONCLUSION

To increase the output current of inverter to $\pm 100A_{pp}$, a

voltage source controller based switching technique is designed since the electrostatic generator has output current in mA ratings. In addition, an LCL filter has designed to reduce higher frequency harmonic distortion and switching loss. A zero-crossing circuit, furthermore, has designed to synchronize the inverter and microgrid phase. The phase angle ratio are 3.3^0 , 3.5^0 and 3.3^0 which are lower than the maximum allowable angle (Phase angle 5^0) as per IEEE standard. The overall PSI system efficiency is 96.8%. The PSI inverter can be applied in high voltage AC microgrid system where synchronization is the primary issue.

REFERENCES

- [1] T. Rahman, S. M. A. Motakabber, M. I. Ibrahimy, and M. G. Mostafa, "Simulation and evaluation of a phase synchronous inverter for microgrid system," *ARNP J. Eng. Sci.*, vol. 11, no. 1, pp. 1-2, Jan. 2016.
- [2] T. Rahman, S. M. A. Motakabber and M. I. Ibrahimy, "Phase synchronous inverter for microgrid system," in *Int. Conf. on Computer and Communication Engineering., IEEE-ICCCE*, pp. 167-171, 2016.
- [3] S. Bal, D. Srinivasan, and A. K. Rathore, "Modular bidirectional current-fed three-phase inverter for microgrid application" In *Power Electron., Intelligent Control and Energy Systems (ICPEICES), IEEE Int. Conf.*, pp. 1-6, Jul. 2016.
- [4] G. Gohil, L. Bede, R. Teodorescu, T. Kerekes, and F. Blaabjerg, "Optimized Integrated Harmonic Filter Inductor for Dual-Converter-Fed Open-End Transformer Topology," *IEEE Trans. Power Electron.*, vol. 32, no. 3, pp. 1818-1831, Mar. 2017.
- [5] T. Rahman, S. M. A. Motakabber and M. I. Ibrahimy, "Design of a switching mode three phase inverters," in *Int. Conf. on Computer and Communication Engineering., IEEE-ICCCE*, pp. 155-160, 2016.
- [6] L. Yang, J. Wang, Y. Ma, J. Wang, X. Zhang, L. M. Tolbert, F. F. Wang, and K. Tomsovic, "Three-Phase Power Converter-Based Real-Time Synchronous Generator Emulation," *IEEE Trans. Power Electron.*, vol. 32, no. 2, pp. 1651-1665, Feb. 2017.
- [7] R. J. Van de Graaff, J. G. Trump, and W. W. Buechner, "Electrostatic generators for the acceleration of charged particles," *Reports on Progress in Physics*, vol. 11, no. 1, pp. 1, 1948.
- [8] T. Rahman, S. M. A. Motakabber and M. I. Ibrahimy, "Low noise inverter for poly phase microgrid system," in *Int. Conf. on Computer and Communication Engineering., IEEE-ICCCE*, pp. 172-176, 2016.
- [9] C. Chen, J. Xiong, Z. Wan, J. Lei, and K. Zhang, "A Time Delay Compensation Method Based on Area Equivalence for Active Damping of an LCL-Type Converter," *IEEE Trans. Power Electron.*, vol. 32, no. 1, pp. 762-772, Jan. 2017.
- [10] T. Rahman, S. M. A. Motakabber and M. I. Ibrahimy, "Three Phase Three Layer Phase Synchronous Inverter for Microgrid System. In Computer and Communication Engineering," in *Int. Conf. on Computer and Communication Engineering., IEEE-ICCCE*, pp. 44-47, 2014.
- [11] D. Brandao, T. Caldognetto, P. Fernando, Marafão, G. Marcelo, Simões, A. José Pomilio, and Paolo Tenti. "Centralized control of distributed single-phase inverters arbitrarily connected to three-phase four-wire microgrids," *IEEE Trans. on Smart Grid.*, vol. 8, no. 1, pp. 437-446, Jan. 2017.