

On the Modeling of Automatic Gain Control in SPICE

J. Vavra¹ and J. Bajer^{1,2}

¹ Dept. of Electrical Engineering, University of Defence, Kounicova 65, 662 10 Brno, Czech Republic

² Dept. of Aerospace Electrical Systems, University of Defence, Kounicova 65, 662 10 Brno, Czech Republic
jiri.vavra@unob.cz

Abstract—Design process of any electronic analog application comprise several steps. One of the essential steps is a computer simulation, usually performed via SPICE or similar simulation software. When the application being designed is a sinusoidal oscillator, the whole task is little bit different, because besides the oscillator circuit, it is also necessary to consider Automatic Gain Control (AGC) circuitry. The paper is focused on a novel and effective way on how to simulate AGC circuitry during the design of a sinusoidal oscillator.

Index Terms—Automatic Gain Control; SPICE Simulation; Sinusoidal Oscillator.

I. INTRODUCTION

Sinusoidal oscillators belong to the category of essential electronic applications. They are applied in various areas from sensor techniques, across communication and control systems, to radiofrequency and microwave circuits. For this reason, new oscillator concepts using different technologies are continually being developed. For each oscillator, it is necessary to ensure their proper function and required parameters, like start-up of oscillations, setting the desired frequency and adjustment of oscillations amplitude and its stabilization [1]. These requirements must be taken into account already in the design process of a particular solution and its verification in simulation software

Proper adjustment and stabilization of amplitude by Automatic Gain Control (AGC) during the simulation process is in reality often neglected aspect. In practice, it may cause the degradation of THD (Total Harmonic Distortion) or different frequency of oscillation from desired. This may occur even if the characteristic equation does not exhibit a relationship between amplitude and frequency. In fact, their mutual dependence can be caused by non-idealities of real electronic components used. Despite this, AGC is in majority of scientific papers focused on novel sinusoidal oscillator neglected and the resulting amplitude of oscillations is consequently given only by inherent nonlinearity of active elements [2]-[10]. In that case, there is also another risk, that that the model used is intended only for operation in linear region. In nonlinear regime, its behavior does not always exactly match the reality.

The realization of the AGC in SPICE environment can be complicated, because it is necessary to continuously obtain the information about actual oscillation amplitude during an ongoing simulation. This information is consequently used in feedback loop to the control adjustable element which influences oscillation amplitude. The aim of the paper is to present a novel way how to effectively do it. Proposed method offers a real-time and non-inertial way for obtaining

actual amplitude of oscillations. Note, that the amplitude of oscillation is often available only in a post-processing phase of simulation.

II. PRINCIPLE OF OSCILLATOR

Sinusoidal oscillator can be generally viewed as an interconnection of two separate blocks – a frequency selective element \dot{B} and a linear amplifier \dot{A} closed together in a loop. A fundamental sinusoidal oscillator conception is shown in Figure 1.

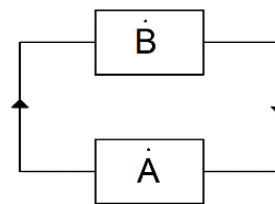

Figure 1: A fundamental sinusoidal oscillator conception

Barkhausen criterion for oscillation can be described in a following form:

$$\begin{aligned} A \cdot B &= 1, \\ \Delta\varphi_A + \Delta\varphi_B &= 2k\pi, \end{aligned} \quad (1)$$

where $\Delta\varphi_A$ represents phase-shift of the amplifier block, $\Delta\varphi_B$ represents phase-shift of the frequency selective circuit, e.g. frequency filter, and $k \in \mathbb{N}$.

Requisite phase shift in a loop is ensured by appropriate circuit topology. Appropriate loop gain should be ensured by additional AGC circuitry. Basic principle of AGC can be demonstrated on an example of Wien bridge oscillator.

A. Wien Bridge

Wien bridge is a 2nd-order band pass (BP) filter with maximal theoretical transfer of 1/3 at the natural frequency, at which is input-to-output phase-shift equal to 0°. Wien bridge circuit is shown in Figure 2.

B. Wien Bridge Oscillator

By replacing voltage source V1 in Figure 2 with a Voltage-Controlled Voltage-Source (VCVS), which will be driven from output voltage with a gain of 3, a Wien bridge oscillator (WBO) can be easily obtained in SPICE. Note, that VCVS is in SPICE designated by letter E. For successful initiation of oscillation an initial conditions must be specified by .IC instruction.

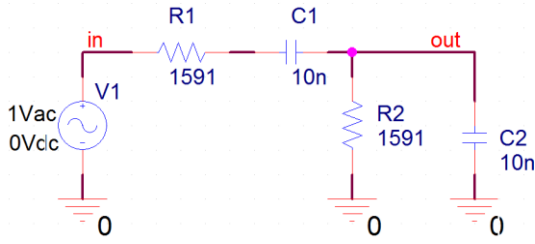

Figure 2: Wien Bridge

An input SPICE file for transient analysis of WBO can be written as follows:

****Ideal Wien Bridge oscillator****

```
R1 in 1 1.591k
C1 1 out 10n
R2 out 0 1.591k
C2 out 0 10n

E1 in 0 out 0 3
.ic V(out) 1

.tran 0 50u 0 10n skipbp
.probe
.end
```

Transient analysis results of an ideal WBO are shown in Figure 3.

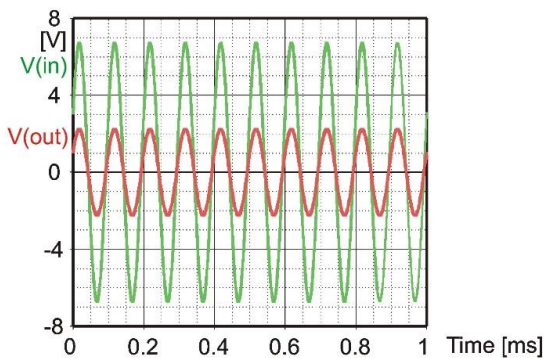

Figure 3: Transient analysis of Wien Bridge Oscillator

III. AUTOMATIC GAIN CONTROL

There are several different approaches, which can be commonly found in publications.

C. Inherent active element nonlinearity

The simplest way how to achieve constant amplitude is a utilization of the active device in a region of its saturation. AGC block is not used in that case. Feedback amplifier gain is fixed at the value little bit higher than required for fulfilling (1). Consequently, the output signal is distorted.

By replacement of ideal voltage source by concrete operational amplifier (e.g. 741) one can obtain results closer to reality. SPICE model of the 741 integrated circuit, which were used, involves also device behavior in saturation area. Simulation results are shown in Figure 4, where the distortion caused by saturation of operational amplifier occurs. The loop gain was intentionally overdriven to emphasize the

phenomenon observed. The results in Figure 4 also show how the oscillation arising after the oscillator is switched on.

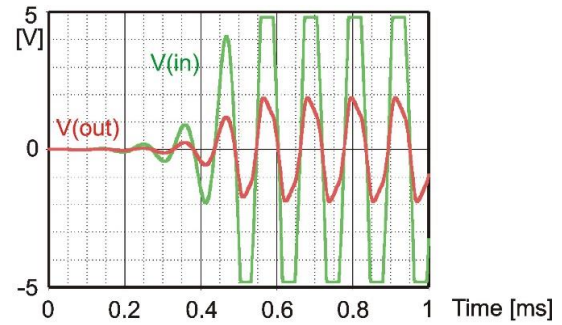

Figure 4: Transient analysis of Wien Bridge Oscillator with operational amplifier

D. Light bulb filament

A loop gain must be controlled depended on amplitude of output signal and not on actual value of the output voltage. All active components used must be in linear regime.

It is obvious, that any nonlinearity in a loop leads to the distortion of the signal generated. However, that distortion can be consequently compensated.

The advantages of the light bulb filament are its non-linear resistance together with its inertia, which enables a filtering of the distortion caused by filament resistance nonlinearity. This solution can be used from a frequency of ca. 100 Hz or more.

E. Antiparallel diodes

This solution utilizes a pair of diodes connected in parallel together with inverse polarity. These diodes serve for clipping of the signal in a loop. The amplitude control is then non-inertial, but causing higher THD. Thus the oscillator must employ frequency filter with higher quality factor for effective filtering of higher components appeared.

F. Photosensitive element with LED

This is a frequently used method, which utilizes various types of photosensitive elements (photo-resistor, photo-transistor, etc.) in combination with LED diode. Light intensity produced by LED is controlled depending on oscillation amplitude. Photosensitive element responds on the light and consequently influences loop gain. This solution is inertial. The advantage is a possibility of easy setup of LED light intensity range and consequently oscillation amplitude via the potentiometer connected to LED.

G. Transconductance amplifier

This is the most modern solution, which utilizes transconductance amplifier in a loop. Transconductance g_m is then controlled electronically depending on oscillation amplitude. A disadvantage of this method is lack of electronically tunable transconductance amplifier in the form of integrated circuit in the market.

IV. AGC IN SPICE

First of all, an amplitude value must be obtained in real time. Based on that value a gain of the feedback amplifier will be calculated. The feedback amplifier is implemented by VCVS. In sinusoidal oscillator, the output signal is represented by sinusoidal waveform. In that case, the

amplitude value can be calculated via the summation of quadrates of sine and cosine functions as follows:

$$(\sin x)^2 + (\cos x)^2 = 1. \quad (2)$$

The phase shift of the output signal can be realized by so-called a Transmission line (*T*) in SPICE with defined time delay. This delay is based on period of the output signal. When the circuit designed is changed, the period of the sinusoidal signal generated will also change. For this reason, the transmission line delay must be carefully adjusted each time. Then this delay must be specified by iteration method according to simulated period of output signal. The transmission line must be correctly terminated in order to suppress the potential reflection. In the node, where the generated signal amplitude is sensed, a voltage buffer must be used in order to prevent a violation of the circuit being designed by auxiliary circuit. After that, the output signal of the oscillator must be delayed as described above. In this way, the cosine signal is prepared for evaluation of the amplitude value. The last part of the feedback amplifier is a VCVS, which calculate the amplitude value according to (2).

A disadvantage of this modeling consists in unreal response during starting of oscillation as shown in Figure 5. The blue trace is calculated as an Amplitude of output signal, the red trace is output signal of frequency filter and green trace is output signal of feedback amplifier.

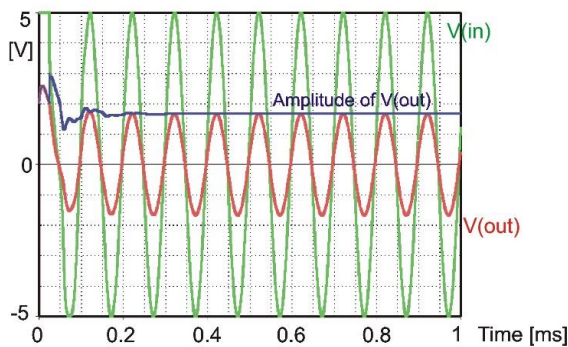

Figure 5: Transient analysis of Wien Bridge Oscillator with AGC

The SPICE input file is as the following:

****Wien Bridge Oscillator with AGC****

```
E1 in 0 VALUE={limit((5*V(out)/
+(PWR(V(out),2)
+PWR(V(out3),2)))),-5,5)}
```

```
E2 out2 0 out 0 1
T1 out2 0 out3 0 Z0=50 TD=25u
R3 0 out3 50
```

```
R1 in 1 1.591k
C1 1 out 10n
R2 out 0 1.591k
C2 out 0 10n
```

```
.tran 0 1m 0u 10n skipbp
.four 10k 1(R1)
.ic V(out) 1
.probe
.end
```

where *E1* is the feedback gain for multiplication of input signal and required amplitude level divided its actual value calculated by sin and cos signals. The output value is limited in range from -5 to 5. *E2* is a separate buffer and *T1* is transmission line with characteristic impedance and time delay. At first, the value of time delay is calculated from ideally frequency of oscillation. The delay must be $\pi/2$ rad, *T*/4 sec respectively (*T* is period of output signal). Ad second, this value can be filling in by actual period after Time analysis of complete circuit. Next part of input file is Wien Bridge and transient simulation settings. The *THD* is calculated from Fourier analysis (.four) with frequency of 1st harmonic. This value is again an ideal, after analysis must by the value corrected by actual value in simulation results with considered real influences.

The gain of the feedback amplifier is very high in beginning of analysis, because the required and actual value ratio is high. This unrealistic result can be solved by two time-divided approaches: At the beginning of the analysis a limited invariable gain will be used and then switched them on the AGC in a defined time.

The dependent source VCVS gain can be programed for two time intervals. This can include real start of oscillation. From the beginning an invariable gain for support the start of oscillation is considered. After that is invariable gain switched to the AGC and settle oscillation. A disadvantage can be behavior during the switching from invariable gain to AGC of the feedback amplifier. Otherwise the results of SPICE simulations are close to real analysis (traces). The settle of oscillation is relatively quick. That is shown in Figure 6.

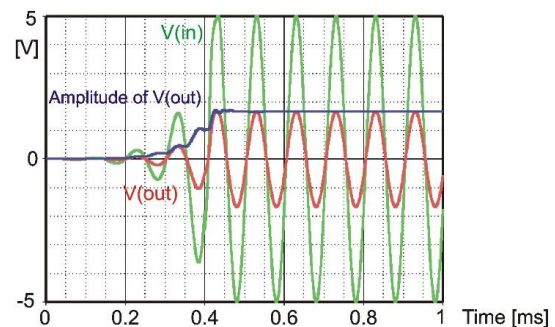

Figure 6: Transient analysis of Wien Bridge Oscillator with AGC

The text of dependent source will be the following:

```
E1 in 0 VALUE=
+{limit((STP(time-400u)*5*V(out)*
+1/((PWR(V(out),2)+PWR(V(out3),2))))+
+((1-STP(time-400u))*3.5*V(out)),-5,5)}
```

A modified text of the feedback- VCVS contains two time intervals. The invariable gain (3.5) is valid for time 0 – 400 μ s, the amplitude level control gain is valid from 400 μ s.

The proposed oscillator with AGC is shown in Figure 7.

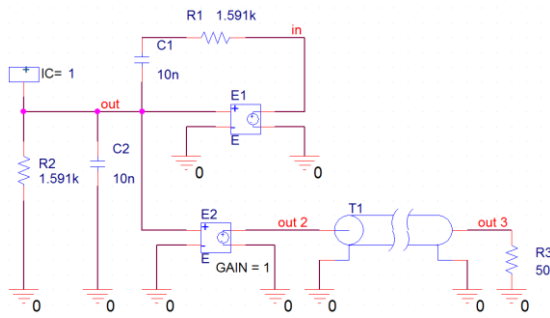

Figure 7: Wien Bridge Oscillator with AGC

V. CONCLUSION

This paper describes a novel way of modeling and SPICE simulation of oscillators with AGC. This method is based on evaluating amplitude by summing a quadrate of sine and cosine signals generated by an oscillator being designed. Not all sinusoidal oscillators are quadrature. That means, not all oscillators provide sine and cosine wave signals simultaneously. In that case, a transmission line can be used to perform a delay of 90° of the sine wave signal which results in a cosine wave signal. The paper also describes some real issues of the proposed method together with possible solutions. Main advantage of the method proposed is a fact that the method is a real-time and non-inertial. Demonstration of the method was performed on a Wien bridge oscillator.

ACKNOWLEDGMENT

The work presented in this article has been supported by the Ministry of Defence of the Czech Republic (UoD development programs for K217 and K206 departments) and

the Ministry of Education, Youth and Sports of the Czech Republic (UoD student research program "Implementation of modern technologies in avionic systems").

REFERENCES

- [1] R. Senani, D. R. Bhaskar, V. K. Singh, R. K. Sharma, *Sinusoidal Oscillators and Waveform Generators using Modern Electronic Circuit Building Blocks*, Springer International Publishing Switzerland, 2016.
- [2] S. Summart, C. Thongsopa, W. Jaikla, "New current-controlled current-mode sinusoidal quadrature oscillators using CDTAs," *Int. J. Electron. Commun. (AEÜ)*, vol. 69, no. 1, pp. 62–68, 2015.
- [3] J. Jin, L. Xiao, X. Yang, B. Liao, S. Li, "Dual-mode multi-phase sinusoidal oscillator with equal amplitudes," *Engineering Review*, vol. 36, no. 3, pp. 211–220, 2016.
- [4] P. Prommee, N. Wongprommoon, "Log-domain All-pass Filter-based Multiphase Sinusoidal Oscillators," *Radioengineering*, vol. 22, no. 1, pp. 14–23, 2013.
- [5] M. Sagbas, U. E. Ayten, N. Herencsar, S. Minaei, "Current and Voltage Mode Multiphase Sinusoidal Oscillators Using CBTAs," *Radioengineering*, vol. 22, no. 1, pp. 24–33, 2013.
- [6] Y. A. Li, "Electronically tunable current-mode biquadratic filter and four-phase quadrature oscillator," *Microelectronics Journal*, vol. 45, no. 3, pp. 330–335, 2014.
- [7] F. Khateb, W. Jaikla, D. Kubanek, N. Khatib, "Electronically tunable voltage-mode quadrature oscillator based on high performance CCCDBA," *Analog Integrated Circuits and Signal Processing*, vol. 74, no. 3, pp. 499–505, 2012.
- [8] F. Yucel, E. Yuçe, "CCII based more tunable voltage-mode all-pass filters and their quadrature oscillator applications," *Int. J. Electron. Commun. (AEÜ)*, vol. 68, no. 1, pp. 1–9, 2014.
- [9] H.-Ch. Chien, J.-M. Wang, "Dual-mode resistorless sinusoidal oscillator using single CCCDTA," *Microelectronics Journal*, vol. 44, no. 3, pp. 216–224, 2013.
- [10] A. Lahiri, N. Herencsar, "CMOS-based active RC sinusoidal oscillator with four-phase quadrature outputs and single-resistance-controlled (SRC) tuning laws," *Int. J. Electron. Commun. (AEÜ)*, vol. 66, no. 12, pp. 1032–1037, 2012.