

Review of Environmental Wireless Sensor Networks System and Design

Mohd Faiz Rohani¹, Kamilia Kamardin^{1,2}, Noor Azurati Ahmad¹, Kamarul Zaman Panatik¹,
Azizul Azizan¹, Siti Sophiayati Yuhaniz¹, Sya Azmeela Shariff¹

¹Advanced Informatics School, Universiti Teknologi Malaysia, Jalan Sultan Yahya Petra, 54100 Kuala Lumpur, Malaysia

²Wireless Communication Centre, Universiti Teknologi Malaysia, Jalan Sultan Yahya Petra, 54100 Kuala Lumpur, Malaysia

kamilia@utm.my

Abstract -The paper presents the review of wireless system networks development for environmental application. An environmental problem such as climate change requires urgent attention. The use of embedded system and wireless sensors make monitoring possible for areas such as remote and harsh environment. Environment parameters such CO₂ and other greenhouse gasses are monitored using the sensor attached to a wireless remote node from a different location and transmitted to the central unit for processing. It is important to use the right type of wireless technology since the remote application requires low power management and resistance to noise. There are several types of modules such as WI-FI, GPRS, Bluetooth, ZigBee and other wireless technology. The related work in this field will be reviewed and factors such as topology, power requirement, and good system design approach will be taken into account for the system review.

Index Terms—Design Review; Environment; Wireless-Sensor Networks.

I. INTRODUCTION

The global warming and climate change have been a global issue for more than a decade. It has given the negative impact to the environment, such as the rise of global temperature, unpredictable weather, and many other natural disasters. Based on International Panel of Climate Change (IPCC) 2007 report [1], human activities that are resulting in emissions of Greenhouse Gases (GHG) contribute to these problems. These gasses will trap heat into the atmosphere causing the rise of earth temperature. It requires urgent action to monitor the phenomena and design a mechanism to control the emissions of greenhouse gasses. Greenhouse gasses are the main cause of the global warming; hence the detection and quantitative measurement of the gasses is very important. The monitoring efforts may help in finding the root cause of the greenhouse emissions and facilitates the authorities in making a decision to control the emissions. The gas sensor has to link to a system in order to bring the data to a central repository for further analysis. The use of wireless system networks is one of available and best options for the application since a wired network may not be accessible in the remote area. There are lots of wireless technology can be used for the design of wireless sensor network such as ZigBee, Wi-Fi, General Packet Radio Service (GPRS), Global System for Mobile (GSM), among others [6]. This wireless network can consist of some number of nodes with sensors attached to them, which must be managed efficiently.

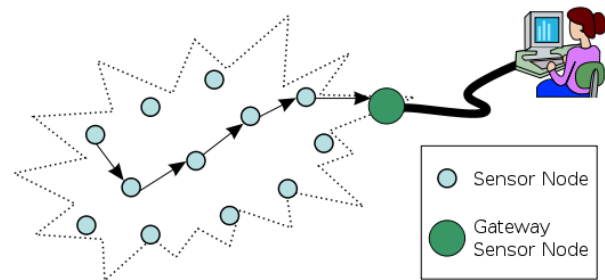

Figure 1: Typical Multi-Hop Wireless Sensor Network

A wireless sensor network (WSN) topology can vary from a star network to a more complicated advanced multi-hop mesh network. Fig. 1 above shows the typical multi-hop wireless sensor nodes architecture with a gateway to relay back the data to the main computer. Message from the end nodes will be transferred along the path to the wireless gateway before it is transferred to the central computer for data logging and analysis [7]. The paper will review the design of the wireless sensor networks, its architecture; technology used, and justifies the effectiveness of the developed wireless sensor model.

II. WIRELESS TECHNOLOGY

There are many types of wireless communication technology that can be simplified as below:

- i. Infrared Communication
Infrared (IR) is electromagnetic radiation with a longer wavelength than visible lights, extending from the nominal red edge of the visible spectrum at 700 nanometers (frequency 430 THz) to 1 mm (300 GHz) [2]. This technology normally is used in short distance with line of sight.
- ii. Wireless Network Communication
Radio frequency ranges from 900MHz to 5GHz within the Industrial, Scientific and Medical (ISM) unlicensed band. The technology is used in Wireless Local Area Network (WLAN) and other types of wireless network. [3]
- iii. Mobile Communication
Communication for Global System for Mobile (GSM) and General Packet Radio Services (GPRS) started from second generation (2G), 3G and 4G cellular networks. Frequency ranges from 800MHz to 2500MHz [4].

iv. Satellite Communication

A communications satellite is an artificial satellite that relays and amplifies through the use of a transponder, radio telecommunications signals, between a source transmitter and a receiver at different locations on Earth. Frequency depends on band (L, S, C, X, Ku, Ka Band) ranges from 1GHz to 40GHz [5].

III. RELATED WORK

Victor and Federico [7] has studied and comparing few options such as Wi-Fi, WiMAX, ZigBee, GPRS and also Bluetooth. Table 1 shows the comparison made between wireless technologies

Table 1
Wireless Technologies Comparison [7]

	Network	Energy	Speed	Distance	Cost
Wi-Fi	LAN	Medium	11-100 Mbps	4-20 Km	Medium
WiMAX	WAN	High	11-1000 Mbps	50 Km	High
ZigBee	LAN	Very Low	250 kbps	0.1-1.6 Km	Low
GPRS	MAN	High	1.8-7.2 Mbps	GPRS Network	High
Bluetooth	PAN	Low	700 Kbps	5-10 m	Low

From the tabulated table above, wireless technologies have been compared in terms of network type, energy, speed, distance covered and cost involved. In this study, the industrial environment has been chosen for the study. Compared to others, it showed the most suitable networks to be used is ZigBee, which is a Personal Area Network (PAN) that can be expandable up to 1.6KM wide. The ZigBee hardware also uses low power consumption, which is very important in a place where the power supply is limited. As shown in Figure 2, the technology offers different topologies that can easily expandable, where sensors or node can be added up in the networks in short time. The wireless networks can be setup as a pair (one to one), star, mesh, and cluster network. Star is the most common technology in network topologies. It consists of central nodes which act as coordinator, with all the other nodes connect to them. A mesh network, on the other hand, the nodes relay the messages through another node and all the nodes cooperates in the distribution of the messages across the network. The nodes have more than one connection to the other nodes, which create a fully connected network. The technology has been designed especially for industrial sensors. It also works effectively in adverse conditions, where the noise is high and low signal condition. The application does not require a high-speed data bandwidth, therefore 250kbps is sufficient to transfer the data generated by the sensor.

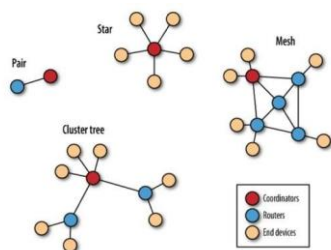

Figure 2: Wireless Topology of Communication Channel [7]

Jongwon et al. [8], developed wireless sensor nodes using Chipcon CC2420 from Texas Instrument that employs ZigBee wireless system connected to a Non-Dispersive Infra-Red (NDIR) based sensors. It has been selected because of its low power consumption usage and endurance in harsh condition. The sensor connected to an internet gateway using Ethernet TCP/IP networks.

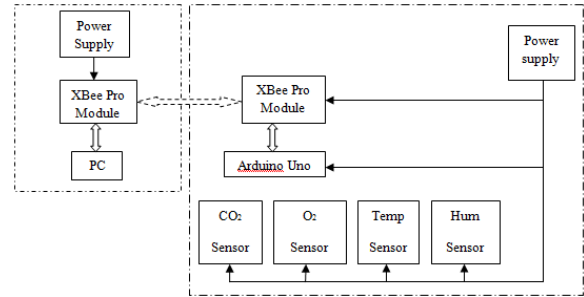

Figure 3: System Architecture for Wireless Sensor Node [6]

Abdullah et al. [6] proposed the same wireless technology for their research as showed in the system architecture as Fig.3 above. The study for carbon dioxide, oxygen, humidity, and temperature has used ZigBee technology connected to a 32-bit microcontroller. The system consists of two main components, data logger and also data interpreter. The data logger has a sensing unit and a base station for data processing. The sensing unit components developed with a sensor attached to the main controller board, and ZigBee (XBee Pro) board for transmitting and receiving data at the base station end. The ZigBee has been selected because it uses 2.4GHz ISM band, with direct sequence spread spectrum (DSSS) which has benefits for resistance against intended and unintended jamming, sharing of a single channel for multiple users, and has the capability of reducing background noise level which hampers the interception. The study focuses on low-cost and low-speed communications between devices, which has lower power consumption with receiver sensitivity of -100dBm (at 1% packet loss rate).

Sudhir G. [9] has developed open source hardware platforms, which used Raspberry Pi microcontroller connected to a wireless module as in Fig. 4 below. ZigBee has been chosen as the wireless technology since it offers low cost, low power and scalable in terms of the number of nodes. It makes the system well suited for a wide variety of applications that related to the environment.

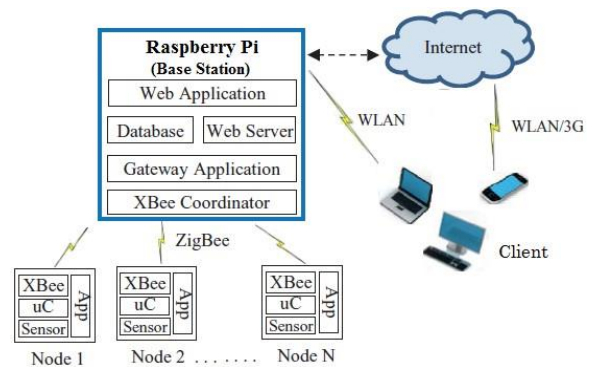

Figure 4: System Architecture for Environmental Application using Raspberry PI [9]

The system consists of sensing unit and a base station and a number of distributed wireless sensor nodes connected

using the ZigBee protocol. The main controller manages several nodes of sensors. The sensor node consists of sensors, controller, and transceiver (Module: XBee). The sensor main function is data collection and as well as data distribution. Furthermore, user application program on each sensor node responsible for data handling from sensors in defined communication protocol with base station.

On the other hand, Xin, Bo, Lei and Zho [10] has developed a system with a binary digital modulation such as Binary Amplitude Shift Keying (2ASK) to communicate the carrier wave. The transmitter and receiver are based on oscillator circuit of three-point capacitance and is composed of amplifying circuit, frequency selective network, feedback network, and the non-linear element. The use of the circuit manages to gather the data from the sensor, but the future expansion of nodes is somehow needed to be done by changing the hardware circuitry. The use of the technology is not limited to a short range wireless technology for the environmental application. Huang et. al. [11] has used GSM as a method to send the sensor data to the PC or mobile phones. The system comprises of 8 modules, which is a master control module, detection module, key set module, liquid crystal display, data storage, communication module (GPRS/GSM), alarm and power supply module. The master module acted as the main control or core for the system. It will analyze the information from the sensors and make disposals. Sensing unit or the detection module consists of a central processing unit, sensors and a communication module. The GSM/GPRS communication unit mainly completes the parameters transmission and helping the users to achieve the remote query function and receive control information.

Wang et al. [12] using a wireless communication module Nordic nRF905 highly integrated, low power consumption multiband RF transceiver IC operating using ISM band. The chip interfaced to an embedded web server based on Samsung S3C2440 that runs on Linux operating system. The functions developed including remote monitor and device remote control. The author believes that the system is stable and suitable for data acquisition on different applications. Park et al. [13] developed a wireless sensor system by using Texas Instruments MSP430MC and CC2420 transceiver chip. They are designed to be separated from each other so that the effect of heat from nodes to the sensor. The processor has 16-bit Reduced Instruction Set Computing (RISC) with a 48KB program and 10KB Random Access Memory (RAM). This will allow simultaneous data handling with high speed. The transceiver chip supports ZigBee specification that works at 2.4GHz.

According to Liu et al. [14], acquiring continuous observation result is an essential demand in environmental monitoring. WSN composed of many sensing components that can be considered a good option to collect a continuous spatial and temporal data. Since the wireless network is prone to electrical noise, the system that will transfer the data has to handle all problem effectively. They have proposed an energy effective embedded system with an internet gateway. The system also has a lead acid battery and a solar cell power supply which are sufficient to supply energy for the monitoring purposes. The use of ARM Mini6410 Microcontroller board as a gateway from FriendlyARM has outstanding performance on chip sizes and low energy consumption. The system also has widely been utilized by wireless and mobile devices. The system has been connected to the backend server through the base node and the GSM

module using a Universal Serial Bus (USB) interface. The embedded system connected to the base node over a USB, so the control command to the communication chip is established to send a control signal and acquires the data regarding the status of the network. The data from the network that has been collected will be stored in the memory. SMS will be used to send the data to the server by GSM module attached.

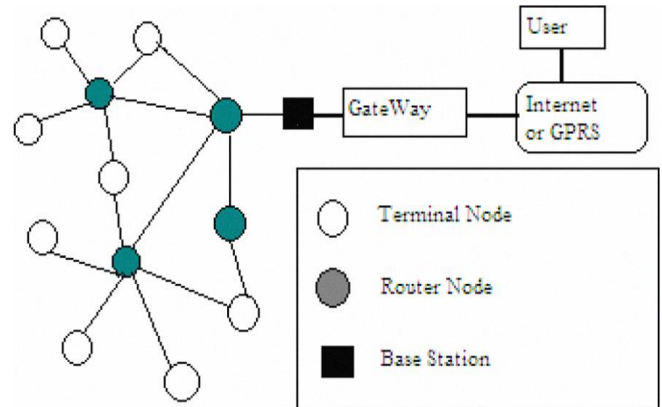

Figure 5: Structure of WSN System [15]

Ye, Gong and Wang [15] has introduced a WSN that monitor several environmental parameters such as ambient temperature, humidity, wind speed, rainfall and other related parameters. The hardware consists of data acquisition, data processing with gateway and data visualization for monitoring. As shown in the Fig. 5, there are three type of terminal nodes: base station, terminal, and router node. Each of them is capable of collecting the sensing data and communicating with other networks. The data can be routed back to the base station through multi-hop architecture. The base station communicates with the gateway to send the data back to the central computers via GPRS or internet connection. The proposed system is using ATmega 1281 microcontroller which has I28K of flash memory, 8K of RAM, and 4K of EEPROM. Wireless module Atmel RF230 which operates at 2.4GHz is being used for the system. The sensor nodes small battery powered device with wireless communication features which have long-time running and easy to be deployed.

In other development, Yang and Li [16] has designed a low power wireless sensor for a long term, autonomous and system that capable of performing the monitoring near real time application. The system has been developed using TinyOS operating system specifically for wireless sensor networks and integrated into Texas Environmental Observatory infrastructure. The deployment of 35 nodes of sensors is for collecting data on soil condition along with other environmental parameters. They have identified the key requirements in designing environmental sensor networks:

- i. Long term energy efficient operation- this is important in energy efficient system because battery powered system could dry out very fast if they operate at high consumption. Low power consumption is the ultimate key sustaining the long-term operation.

- ii. Reliable data collection – the data has to be collected in reliable manner because data loss can cause distorted observation.
- iii. Near real-time data collection – environmental parameters are usually varied slowly and response time can be traded off for energy efficiency in environmental monitoring systems.
- iv. Scalability – environment sensor networks need to be scalable to suit wide range of applications
- v. Unattended autonomous operation – the sensor network needs capability of self-configuration and organization as well as self-healing in the case of nodes failure
- vi. Load balance – The load of the network needs to be well balanced to maximize overall network lifetime.

While Ye, Min and Wang [17] in their research has proposed a gateway system to connect the sensor network to external network for data storage and processing. The gateway will gather the data from the sensor networks and for security reason; the nodes connected to the gateway will be registered. They have designed a web service for the user accessing the gateway from a long-distance. The gateway system has using embedded database SQLite, and S3C2440 chip of ARM9 as the microprocessor which is known for its low power consumption yet high in performance. The system is 64M SDRAM and 64M NAND Flash memory for Linux operating system and its application. The data received will be stored in 2GB SD card. The sensor nodes connected to the sink node which gathers the data before sending it out to the gateway which has better processing capability. The gateway can be accessed locally or through the internet. It uses DM900 Ethernet Controller for fast Ethernet connectivity which is running at 100Mbps. Besides the Ethernet, it also has GPRS module for connectivity through the mobile communication networks.

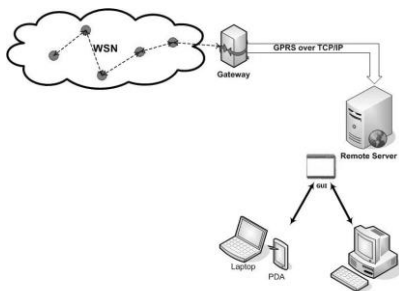

Figure 6: System Architecture for Sensor Network [18]

Manes et al. [18] have developed their version of WSN, which can be seen in Fig. 6. The system comprised of self-organizing network with sensing capabilities, a GPRS gateway for data gathering which providing TCP/IP connection toward the remote server. This will allow user to monitor and interact with the instrument. The sensor node is using 868 MHz Mica2 motes with TinyOS running in the system that are capable of attaining optimized power management and provides system portability towards future changes. To manage different kind of sensors, a compliant sensor board has been adopted which allowed 16 sensors plugging on the same node hence making a single mote able to sense multiple environmental parameters at a time.

IV. SYSTEM REVIEW AND DISCUSSION

The comparison of the studies can be simplified in the following Table 2. The research on environmental monitoring has focused on a system that can overcome challenges in the field. From the current review, the choice of technology to be implemented is important to ensure the proposed systems can operate effectively. The wireless technology like ZigBee has good characteristics such as lower power consumption, ability to self-configure and self-healing makes network expansion easy [19]. Energy consumption is another issue that the developer need to consider; in order to produce a wireless sensor system with low power consumption but yet offer good and effective sensing and data transferring capabilities. The use of a small operating system that is designed for low power embedded devices such as the TinyOS [20] is another solution to achieve effective devices energy and memory management. Through the internet, the data from the sensors can be transferred from the remote location to another place for processing and monitoring. Hence the interfacing of the sensors to an internet gateway has become a must to any of wireless systems.

Table 2
Review of Environmental Wireless Sensor Networks System and Design

Author	Technology	Advantages
Victor, Federico [7]	ZigBee Module	Energy effective, scalable
Jongwon et al. [8]	ZigBee Module	low cost, Web /Remote Accessibility, scalable
Abdullah et al [6]	ZigBee Module	Energy effective, accurate, low cost, scalable
Sudhir G. [9]	ZigBee Module	Energy effective, accurate, low cost, scalable
Xin, Bo, Lei and Zho [10]	Hardware Circuit	Energy effective, acceptable performance
Huang et al. [11]	Hardware Circuit	Remote accessibility Energy effective, acceptable performance
Wang et al [12]	Hardware Circuit	Remote accessibility Energy effective acceptable performance
Park et al. [13]	Hardware Circuit	Remote accessibility Energy effective good performance
Liu et al [14]	Sensor Mote	Remote accessibility Energy effective good performance
Ye, Gong and Wang [15]	Sensor Mote	Remote accessibility acceptable performance
Ye, Min and Wang [17]	Hardware circuit	Gateway design
Manes et al.[18]	Sensor Mote	Remote accessibility Energy effective good performance

V. CONCLUSION

The paper reviewed wireless sensor technology development in environmental monitoring application. There are many criteria to be considered when building a sensor system to be deployed at site, mainly because of its harsh surrounding environment. Factors such as energy consumption, durability, accessibility, network performance and security are the challenges that one has to consider to build a good and effective wireless sensors system.

ACKNOWLEDGMENT

This work was supported by Universiti Teknologi Malaysia (UTM) and Ministry of Higher of Education (MOHE) under grant no. 02K02 and 15H97. The authors would like to thank UTM, MOHE and Advanced Informatics School (AIS), UTM Kuala Lumpur the funding and facilities.

REFERENCES

- [1] Intergovernmental Panel on Climate Change <https://www.ipcc.ch/>, Accessed on 25/11/15
- [2] Infrared <https://en.wikipedia.org/wiki/Infrared>. Accessed on 25/11/15
- [3] Wireless Network https://en.wikipedia.org/wiki/Wireless_network. Accessed on 28/11/15
- [4] Cellular Network https://en.wikipedia.org/wiki/Cellular_network. Accessed on 28/11/15
- [5] Communication Satellite https://en.wikipedia.org/wiki/Communications_satellite Accessed on 28/11/15
- [6] Abdullah, A.; Sidek, O.; Amran, N.A.; Za'bah, U.N.; Nikmat, F.; Jafar, H.; Hadi, M.A., "Development of wireless sensor network for monitoring global warming," in *Advanced Computer Science and Information Systems (ICACSIS)*, 2012 International Conference on , vol., no., pp.107-111, 1-2 Dec. 2012
- [7] Escorza, V.A.; Guedea, F., "A Wireless Sensors Network Development for Environmental Monitoring Using OPC Unified Architecture in a Generic Manufacturing System," in *Mechatronics, Electronics and Automotive Engineering (ICMEAE)*, 2014 International Conference on , vol., no., pp.187-192, 18-21 Nov. 2014
- [8] Jongwon Kwon; Gwanghoon Ahn; Gyusik Kim; Jo Chun Kim; Hiesik Kim, "A study on NDIR-based CO2 sensor to apply remote air quality monitoring system," in *ICCAS-SICE*, 2009 , vol., no., pp.1683-1687, 18-21 Aug. 2009
- [9] Nikhade, S.G., "Wireless sensor network system using Raspberry Pi and zigbee for environmental monitoring applications," in *Smart Technologies and Management for Computing, Communication, Controls, Energy and Materials (ICSTM)*, 2015 International Conference on , vol., no., pp.376-381, 6-8 May 2015
- [10] Zhang Xin; Du Bo; Feng Lei; Liu Wen-zhou, "Development of the wireless environmental monitoring system," in *Computer Application and System Modeling (ICCASM)*, 2010 International Conference on , vol.8, no., pp.V8-225-V8-228, 22-24 Oct. 2010
- [11] Hesong Huang; Hongning Bian; Shuchuan Zhu; Jibo Jin, "A Greenhouse Remote Monitoring System Based on GSM," in *Information Management, Innovation Management and Industrial Engineering (ICII)*, 2011 International Conference on , vol.2, no., pp.357-360, 26-27 Nov. 2011
- [12] Zhisong Wang; Shihua Li; Qi Hao; Linlin Li; Guotao Zhai, "Research of intelligent greenhouse remote monitor system based on embedded network and wireless transmission technology," in *Electrical and Control Engineering (ICECE)*, 2011 International Conference on , vol., no., pp.1688-1691, 16-18 Sept. 2011
- [13] BeomJin Kang; DaeHeon Park; KyungRyung Cho; Changsun Shin; SungEon Cho; JangWoo Park, "A Study on the Greenhouse Auto Control System Based on Wireless Sensor Network," in *Security Technology, 2008. SECTECH '08. International Conference on , vol., no., pp.41-44, 13-15 Dec. 2008*
- [14] Chun-Yi Liu; Cheng-Long Chuang; Chia-Pang Chen; Wan-Yi Chang; Jyh-Cheng Shieh; Cheng-Han Lin; Chwan-Lu Tseng; Joe-Air Jiang, "Development of an embedded system-based gateway for environmental monitoring using wireless sensor network technology," in *Sensing Technology (ICST)*, 2011 Fifth International Conference on , vol., no., pp.544-548, Nov. 28 2011-Dec. 1 2011
- [15] Dunfan Ye; Daoli Gong; Wei Wang, "Application of wireless sensor networks in environmental monitoring," in *Power Electronics and Intelligent Transportation System (PEITS)*, 2009 2nd International Conference on , vol.1, no., pp.205-208, 19-20 Dec. 2009
- [16] Jue Yang; Xinrong Li, "Design and implementation of low-power wireless sensor networks for environmental monitoring," in *Wireless Communications, Networking and Information Security (WCNIS)*, 2010 IEEE International Conference on , vol., no., pp.593-597, 25-27 June 2010
- [17] Ye Dun-fan; Min Liang-liang; Wei Wang, "Design and Implementation of Wireless Sensor Network Gateway Based on Environmental Monitoring," in *Environmental Science and Information Application Technology, 2009. ESIAT 2009. International Conference on , vol.2, no., pp.289-292, 4-5 July 2009*
- [18] Manes, G.; Fantacci, R.; Chiti, F.; Ciabatti, M.; Collodi, G.; Di Palma, D.; Manes, A., "Enhanced System Design Solutions for Wireless Sensor Networks applied to Distributed Environmental Monitoring," in *Local Computer Networks, 2007. LCN 2007. 32nd IEEE Conference on , vol., no., pp.807-814, 15-18 Oct. 2007*
- [19] Shiwei Zhang; Haitao Zhang, "A review of wireless sensor networks and its applications," in *Automation and Logistics (ICAL)*, 2012 IEEE International Conference on , vol., no., pp.386-389, 15-17 Aug. 2012
- [20] Herrera-Quintero, L.F.; Macia-Perez, F.; Ramos-Morillo, H.; Lago-Gonzalez, C., "Wireless Smart Sensors Networks, systems, trends and its impact in environmental monitoring," in *Communications, 2009. LATINCOM '09. IEEE Latin-American Conference on , vol., no., pp.1-6, 10-11 Sept. 2009*