

Intelligent Home: Automated, Secured & Medically Monitored

Farrukh Hafeez, Muhammad Hamid, Ameer Azhar
EEE Department, Jubail Industrial College, Jubail, KSA.
hafeez_f@jic.edu.sa

Abstract—This research focuses on Intelligent Home with security system, indoor and outdoor automation system and medical monitoring system with a mobile alert for retarded and impaired person. It presents the use of Android application to implement home security using RFID, dealing with outside home automation system using automated irrigation system techniques, inside home automation using smart sensors and medical remote monitoring system using implanted RFID tag. Voice commands and voice feedback and acknowledgment are also parts of the proposed system.

Index Terms—RFID Tag; Implanted; Bio Sensors; Medical Tag; Irrigation Control; Voice Recognition; Wireless Sensors.

I. INTRODUCTION

The idea of Smart Home was first proposed in 1980's with the intent on making homes more intelligent [1]. In the early 90's, the focus has turned to innovate lives for disabled people as the elderly and disabled population have been increasing. Researches have been conducted in various areas, such as controlling home appliances through voice and mobile [2] or using wireless sensor network [3], and an automated irrigation system that uses wireless network of soil-moisture and temperature sensors placed for measuring humidity, temperature etc. In addition, it can handle sensor information, triggers actuators, and transmits data to a web application. [4].

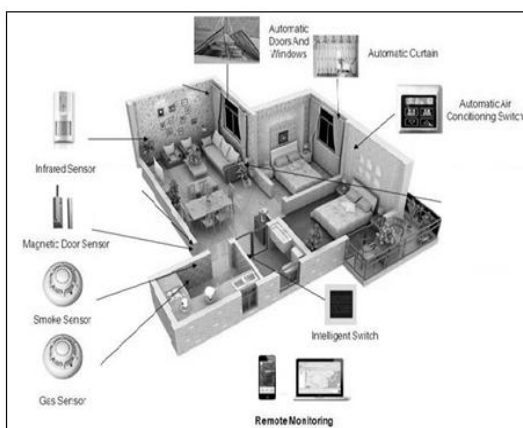

Figure 1: Home automation systems

RFID has been adopted universally and recognized for providing security to access control of resources. RFID has the advantages of fast scanning, environment friendly capability, persistence, accuracy, barrier free reading, and enormous data memory size [5]. Data can be accessed and reserved, as well as delivered anytime, anywhere if RFID is connected with the wireless network [6]. Distant monitoring

systems have the ability to mitigate challenging patient access issues. Nearly 20% of those in the US live in rural areas, but only 9% of the physicians work in rural areas. Wireless biosensors are used to gather physiological and movement data, thus enabling effective patient's conditioning monitoring. Sensors are setup according to the clinical application of interest [7].

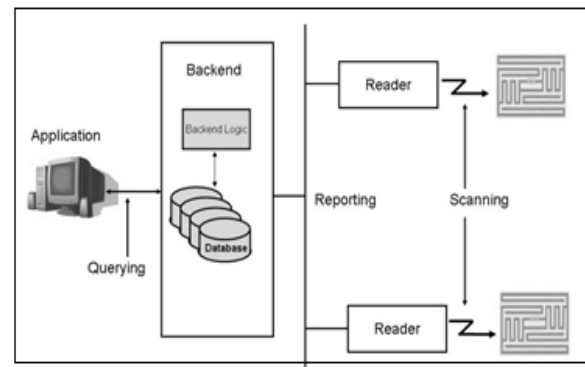

Figure 2: General RFID systems

Though several popular home automation modules are available, few of them are compatible to use with physically challenged and impaired persons. Most of them are aimed at automatic control of indoor appliances; some systems focus just on automatic irrigation and for monitoring a person's medical parameters. The objective of this paper is to present a complete home system and all these systems are correlated with each other. The proposed system is not just limited to voice controlled-based appliances, but it also integrates multiple systems. The rest of this paper is organized as follows: Section III explains RFID based security system for providing access control to authorized users. Section IV explains the automated irrigation concept for providing efficient use of resources in an irrigation system. Section V explains the voice-based control and acknowledgment system of home appliances and section VI explains the implementation of human body with implanted biosensors based monitoring system and finally, section VII explains the integration of all components to form a complete and practical system.

II. RFID BASED SECURITY SYSTEM

One of the most important concerns for impaired and disabled person is security as it can be easily considered that a person with disability is unable to take any abrupt action in any unexpected circumstances. In RFID system, IR sensor detects the presence of a person approaching RFID system.

The message of showing RFID will be displayed on LCD. An authorized user can be entered any time, on the entrance of the authorized user, welcome message “MR. XYZ” will appear on LCD and a voice message will be sent informing that MR. XYZ has entered the premise. In case, a wrong RFID is attempted to access, an alarming voice message will be generated. All voice messages for informing and voice instructions to perform anything or to control/stop any application (in case needed) can be recorded and saved.

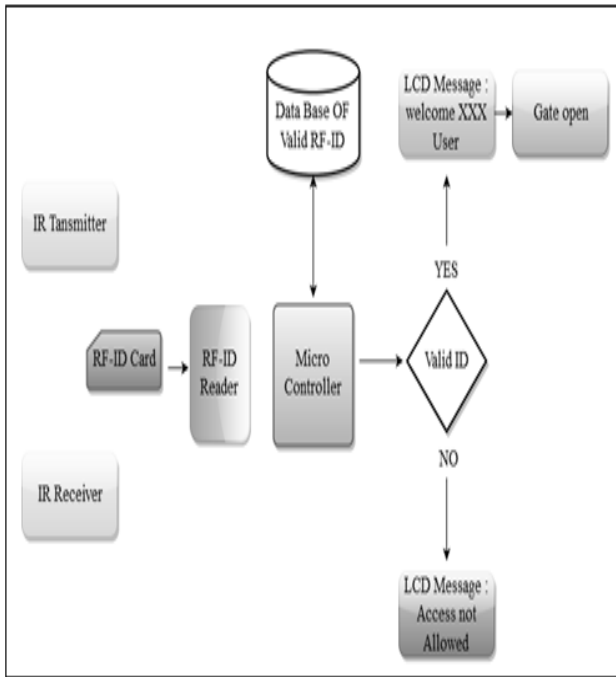

Figure 3: Block diagram of RFID based security system

III. AUTOMATED IRRIGATION SYSTEM

To irrigate at regular time interval for predefined periods is heuristically based on experience. In our proposed auto irrigation system, we used three sensors, namely the soil sensor, light sensor and temp/humidity sensor. The soil sensor is basically a pair of metal probes that are plunged in the soil to know the moisture level: If it falls below the programmed moisture level, the pump connected to the sprinkler will start to watering. LDRs are installed to get better results for sensing the light intensity level and operating gardening lights automatically. The LDR can be installed on multiple places. DHT 11 sensor is used to measure current temperature and humidity levels. Programmed ranges applications such as fan and many others can be operated, in case there is a deviation of the humidity and temperature.

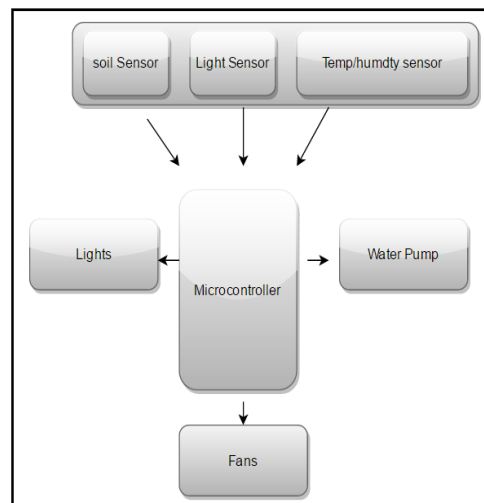

Figure 4: Block diagram of Automated Irrigation system

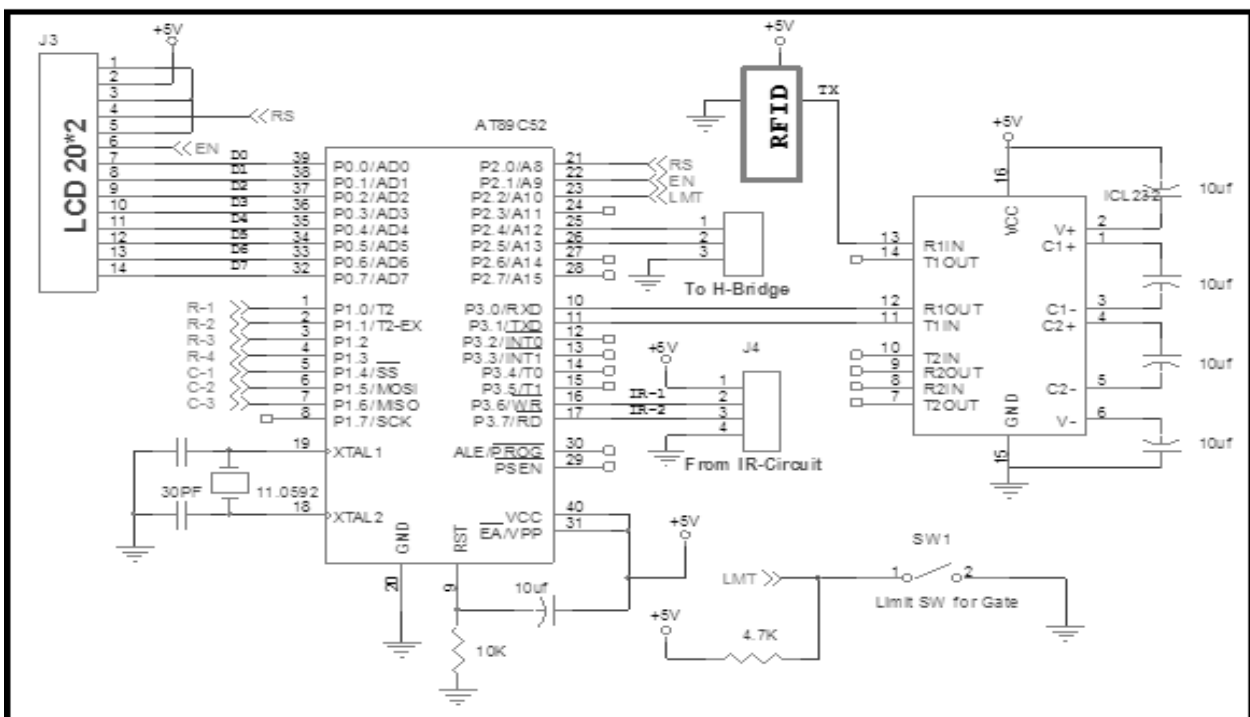

Figure 5: Circuit diagram of RFID based security system

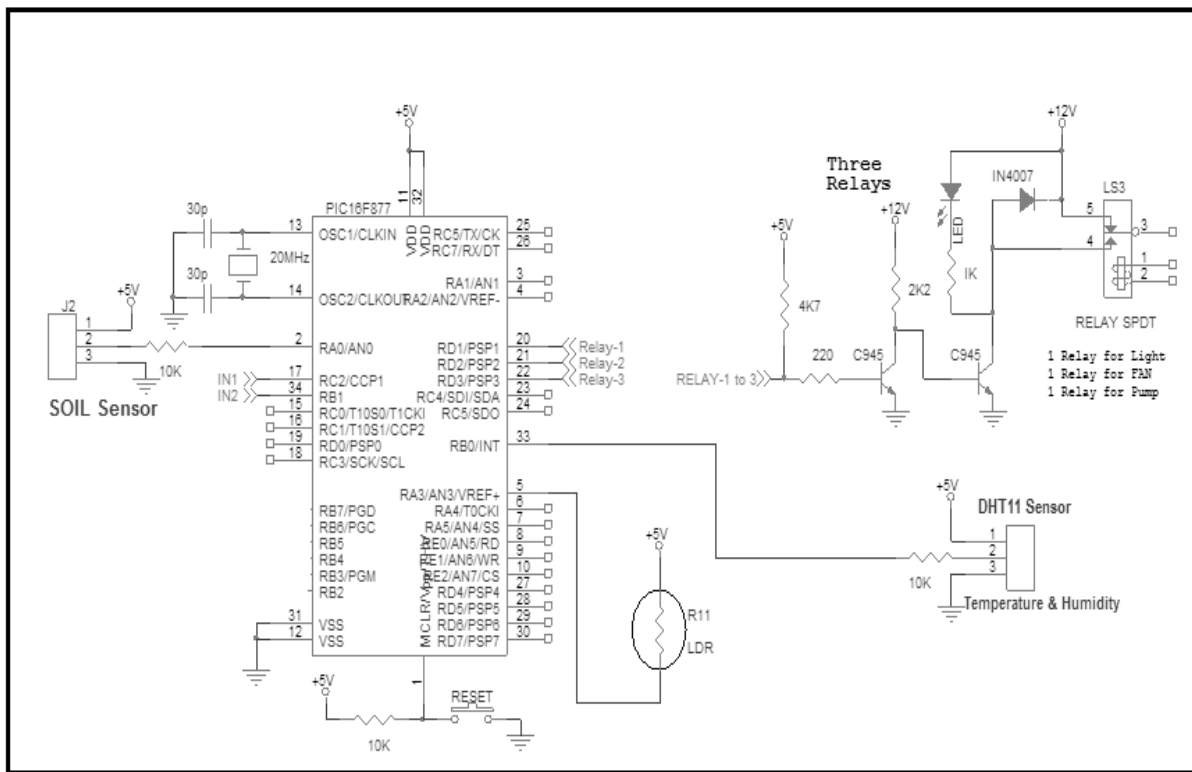

Figure 6: Circuit diagrams of Automated Irrigation system

IV. VOICE CONTROL BASED AND ACKNOWLEDGMENT SYSTEM OF HOME APPLIANCES

In this section, the implementation of voice control based home automation and acknowledgment system with best possible sensors suited is explained. There are two things that should be considered. Firstly, some parameters can be controlled automatically by the sensors, such as the temperature, humidity etc. by setting the predefined values. Secondly, some appliances like TV, sound system etc. should be operated on demand and for such systems, voice commands can be used. Feedback acknowledgment system is implemented for both the sensor-controlled and voice-controlled systems to ensure that a particular task has been done or status of the device has been changed. User voice for sending and receiving message is done through Wi-Fi connected headset with a mobile application installed in the mobile.

V. IMPLANTED RFID BASED PATIENT MONITORING SYSTEM

Monitoring of health parameters for a person living alone with some disabilities is the prime object to be considered in this research. The use of human body implanted biosensors with RFID tag is applicable and useful for two main scenarios. Firstly, it can be used to inform others who are far away, and secondly, it can be used to monitor anyone who has symptoms, which he/she is not aware of. Any physiological changes can be detected, recorded, and transmitted using the biosensor. When the biosensor-based devices are connected to human-centric RFID, the biosensors gain the functionality to transmit information to the source [8]. Implantable biosensors allow the measurement of body temperature. Moreover, diabetes sufferers have been proven in concept by biotechnology

firms [9]. Device monitoring parameters, like blood pressure, sugar etc. connected to wireless LAN provide the mobility of a patient and allow a physician to get a patient's medical information easily without spending time. Further, history can be recorded as well.

VI. COMPLETE SYSTEM

The system is aimed to design a voice controlled and voice acknowledgment system to inform the user about its current status. The system follows a simple design for installation and usage. Currently, the voice recognition software is available to be applied in smart phones. In case, where it is not used for smart phones, the design of such software is not required. The voice instructions messages, voice acknowledgment, emergency messages keep user informed and it can be recorded. Moreover, any voice acknowledgment message can be enabled or disabled at any time.

VII. CONCLUSION

The proposed Home system is very useful for a physically disabled person who is not able to perform various activities. The system is not just limited to indoor home automation or typical irrigation system, but it also monitors the person's medical condition without disturbing any daily activities and shares the person's medical information. The indoor automation system provides safety by using smoke or carbon monoxide sensors, glass break sensors together with an automation system. The proposed model is capable of managing security by implementing RFID based security system, allows authorized users to access with voice acknowledgment and also inform the presence of an unauthorized user. Automated Irrigation system works by measuring the temperature, humidity and moisture sensing.

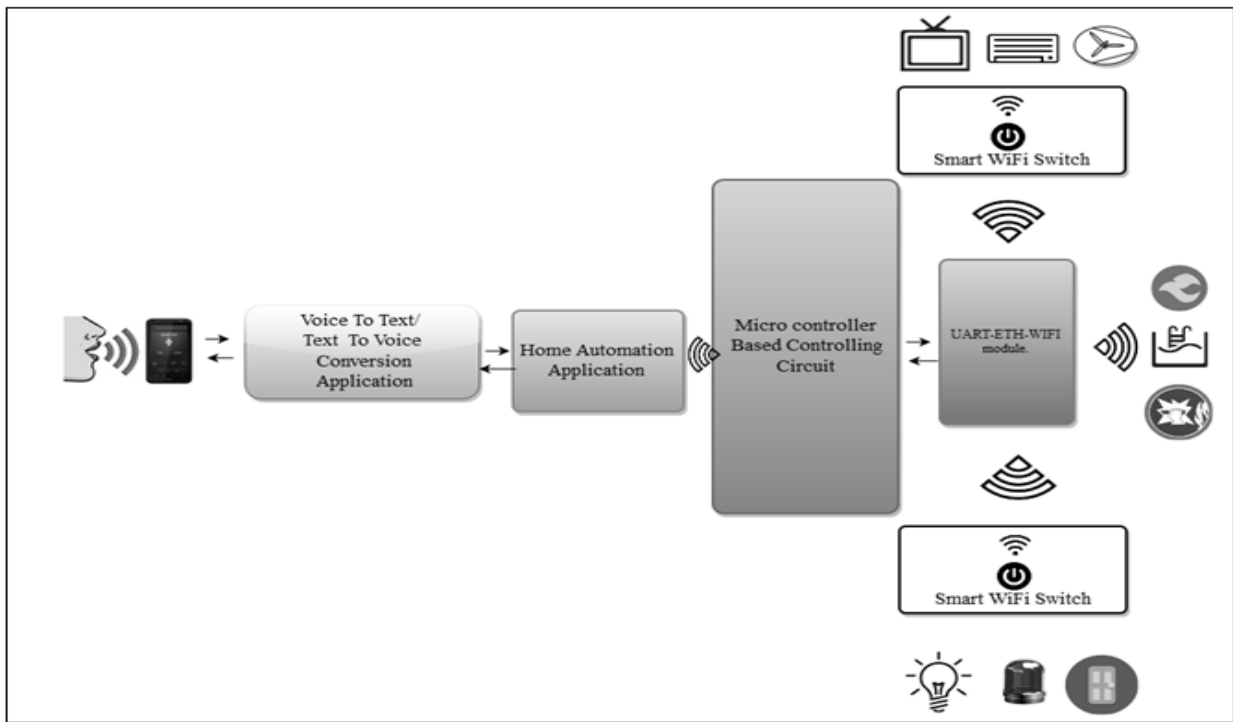

Figure 7: Block diagram of Home Automation system

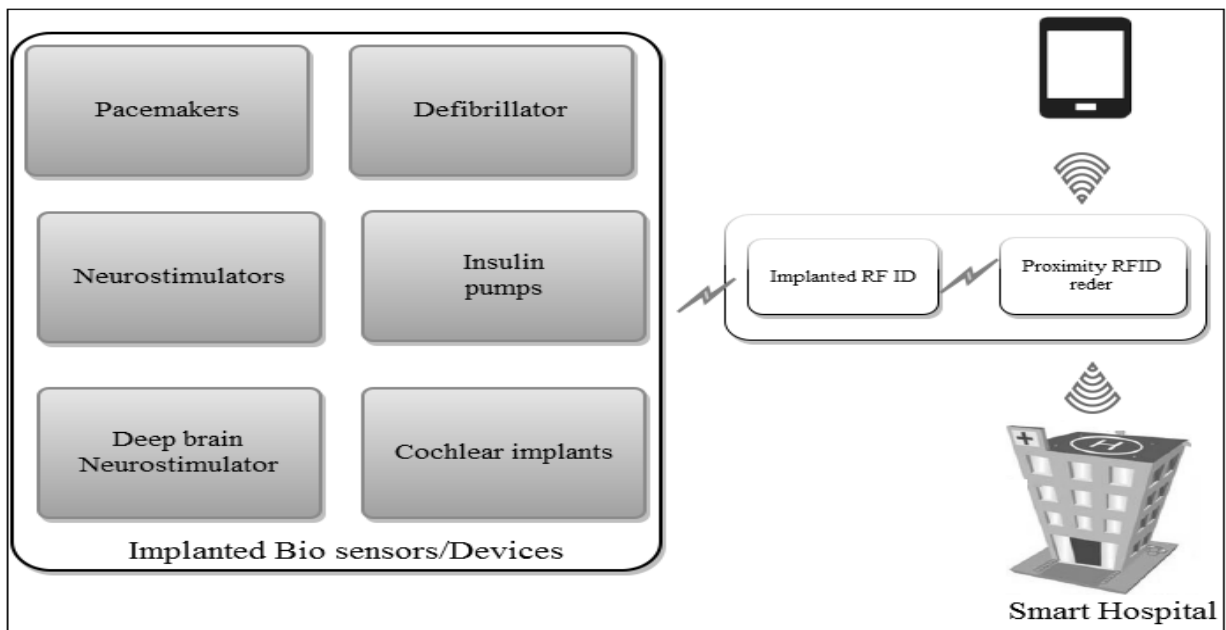

Figure 8: Block diagram of Patient Monitoring System

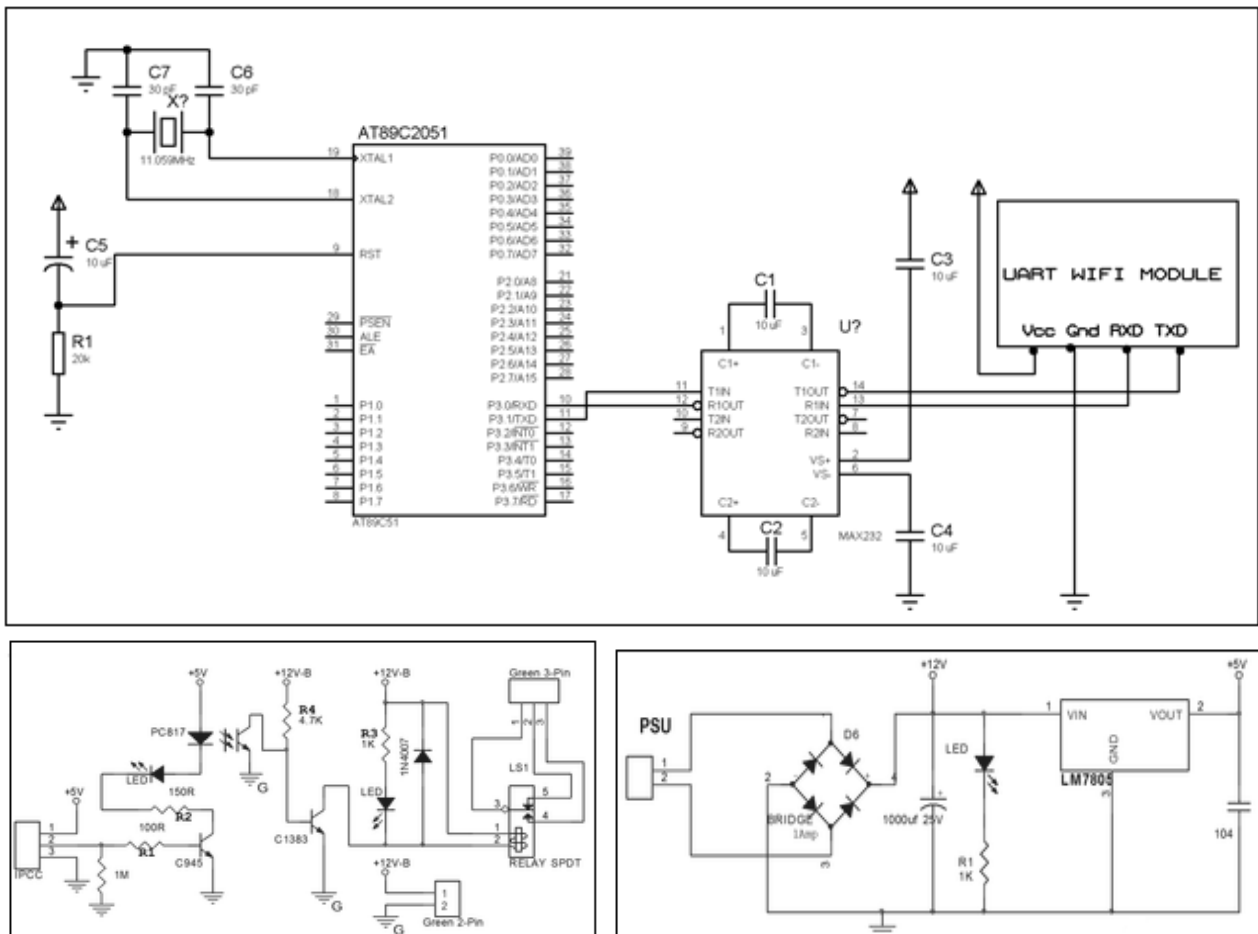

Figure 9: Circuit diagram of Home Automation system

REFERENCES

- [1] Gerhart, J. (1999). Home automation and wiring. McGraw-Hill. (ISBN 0070246742).
- [2] Portet. François, "Design and evaluation of smart home voice interface for the elderly: acceptability and objection aspects", Personal and Ubiquitous Computing", Volume 17, PP 127 - 144, Jan 2013.
- [3] Mingfu Li, "Design and Implementation of Smart Home Control Systems Based on Wireless Sensor Networks", IEEE Transactions on Industrial Electronics, 2015, Volume 62, Issue 7, PP 127 - 144, Jan 2013.
- [4] Kaldeli, Eirini, "Coordinating the web of services for a smart home" ACM Transactions on the Web (TWEB), Volume 7, Issue 2, PP 1-6, May 2013.
- [5] Shiraz Afzal, "Review of Various Aspects of Radio Frequency Identification (RFID) Technology" IOSR Journal of Computer Engineering (IOSRJCE), Volume 8, PP 01-06, Nov 2012.
- [6] Da Wei Xu, "Design of Wireless Sensor Network Node Based on RFID Technology", Applied Mechanics and Materials, Volume 602-605, PP 966, Aug 2014.
- [7] AlSharqi, Khalifa, "Zigbee Based Wearable Remote Healthcare Monitoring System for Elderly Patients", International Journal of Wireless & Mobile Networks, Volume 6, Issue 3, Jun 2014.
- [8] Karoliina Koski, "A New Approach and Analysis of Modeling the Human Body in RFID-Enabled Body-Centric Wireless Systems" International Journal of Antennas and Propagation, Volume 2014, PP 1-12, Jan 2014.
- [9] Anna Gina Perri, "RFID Technology for Biomedical Applications: State of Art and Future Developments" i-Manager's Journal on Electronics Engineering, Volume 6, Issue 2, PP 1-10, Dec 2015.
- [10] Marrocco, G, "Design of Implanted RFID Tags for Passive Sensing of Human Body", IEEE Transactions on Antennas and Propagation, Volume 60, Issue 7, PP 3146 - 3154, 2012.
- [11] Amendola, "RFID Technology for IoT-Based Personal Healthcare in Smart Spaces", IEEE Internet of Things Journal, Volume 1, Issue 2, PP 144-152, Jan 2014.
- [12] Yenenesh Alemu, "A Low Cost Microcontroller-based Automated Irrigation System for Two Ethiopian Crops in a Dry Area", Technology and Arts Research Journal, Volume 4, Issue 3, PP 192, July 2015.