

Design and Implementation of Vital Signs Simulator for Patient Monitor

Jipcy Maurris N. Narvaez¹, Glenn O. Avendaño²

¹Malayan Colleges Laguna, Pulo-Diezmo Road, Cabuyao City, Laguna, Philippines.

²Mapua Institute of Technology, Muralla St., Intramuros, Manila, Philippines.

jmnarvaez@mcl.edu.ph

Abstract—This study focuses on the design and implementation of vital signs simulator for patient monitors. A patient monitor has three major monitoring systems, including pulse oximeter, electrocardiogram (ECG) and Non-Invasive Blood Pressure Monitor. Medical equipment should be calibrated on a frequency basis, but simulations of vital signs are some of the ways to calibrate the reading of a patient monitor. The study included a prototype that can simulate the oxygen saturation and pulse rate for pulse oximeter, ECG pulse rate and waveform (normal and arrhythmias) and systolic and diastolic pressure and pulse rate for Non-Invasive Blood pressure monitor. Arduino microcontroller served as the main processing unit of the simulator of vital signs.

Index Terms—Simulator; ECG; NIBP; Pulse Oximeter; Vital Signs.

I. INTRODUCTION

Medical equipment provides important information needed by medical personnel in assessing patient's health. Patient monitors have become one of the widely used equipment in health care management because they are non-invasive, easy to use, and continuously provide alarms for different health problems. Patient monitors are a combination of an electrocardiogram (ECG), pulse oximeter (SpO₂) and non-invasive blood pressure (NIBP) monitors. Electrocardiogram (ECG) provides the information of the heart muscle's electric activity and can reveal malfunction on heart conduction and rhythm. Pulse oximeter (SpO₂) provides arterial oxygen saturation or oxygen level in tissues, information vital in oxygenation of patients. Non-invasive blood pressure (NIBP) monitors provide the systolic or the maximum blood pressure in the arteries when heart beats during contraction of heart muscle and the diastolic or the minimum pressure in the arteries when heart beats during resting of heart muscle. Preventive maintenance of patient monitors requires specialized simulators for each of the parameters it provides. Specialized simulator should include ECG simulator that simulates the waveform of the heart's electrical activity, pulse oximeter simulator that simulates the oxygen concentration of a patient and NIBP simulate that simulates the systolic and diastolic pressure of a patient. These simulators can counter check the accuracy and precision of patient monitors for each parameter they provide.

Many developing countries are increasingly dependent on second hand equipment to meet the needs of their health care systems. However, since not all important parameters are taken into consideration, donations sometimes do not achieve their intended objectives and could even constitute

an added burden to the recipient health care system. According to Perry and Malkin, an average of 38.3% of medical equipment in developing countries is out of service [1]. The three main causes are the lack of medical personnel training, poor health care technology management and inadequate infrastructure. Maintenance personnel do not have the proper tools needed in checking medical equipment, leading the health care facilities to use unchecked medical equipment. Health care facilities can only verify the second hand equipment based on aesthetic and working condition of the equipment. Even the highly skilled personnel cannot maintain or countercheck the performance of medical equipment without the specialized equipment designed for testing their performance.

The lack of medical equipment simulators in developing countries is due to inadequate information of their importance in maintaining medical equipment and insufficient resources of some health care facilities. Without medical equipment simulators, a countercheck of the accuracy and precision of medical equipment's reading is impossible to achieve. Inability to check the accuracy and precision of medical equipment will lead to a poor performance of the medical equipment, thus resulting in a poor health care management of patient.

The goal of the study was to design a vital sign simulator with adjustable parameters for patient monitors. The simulator provided normal waveform with adjustable beats per minute and waveforms for ECG, adjustable oxygen saturation level and pulse rate for pulse oximeter and lastly adjustable systolic and diastolic pressure and adjustable pulse rate for NIBP monitors. This study also validated the experimental results with that of expected output.

The study is beneficial to hospital personnel in developing countries by providing them a tool for maintaining and calibrating their patient monitors. The study will help the engineering department to countercheck whether the patient monitors they purchased are within the specifications or not. Medical staff will also be assured that the patient monitors are reliable and accurate so that they can provide the correct diagnosis for the patient at any given time when using the patient monitors.

The study will implement a prototype that does not have any decision capability, but can simulate vital signs such as pulse rate, oxygen saturation, blood pressure, normal ECG waveform and arrhythmias. Non-invasive pulse oximeter, non-invasive electronic blood pressure monitor and ECG with three and five leads will be considered in the study. The study will not cover the decision of the engineering personnel whether the equipment being tested or calibrated is within the specifications or not.

II. METHODOLOGY

Figure 1 shows the conceptual framework of the study. Switches serve as the input of the system. Pressure sensor is used to measure the pressure in the cuff of NIBP and serves as an input to the system during NIBP simulation. It is also used to select the simulation to be performed, set ECG waveform beats per minute, select oxygen concentration and pulse rate for pulse oximeter simulation, select systolic and diastolic pressure together with the pulse rate for NIBP simulation. Arduino microcontroller serves as the main processing unit for the system, while the microcontroller sets the values of different parameters, computation, decision and measurement of the process to be conducted inside the microcontroller. The LCD is used to display the parameters set for each simulation and the ECG connector serves as the output for ECG simulation where the leads of ECG monitors are connected. IR and RED LED serve as the output for pulse oximeter simulation wherein the sensor of a Pulse oximeter is connected. Compressor serves as the simulation of blood pressure for NIBP. Circuit implementation of the system is shown in Figure 2. Two microcontroller were used due to the limitation of the available outputs.

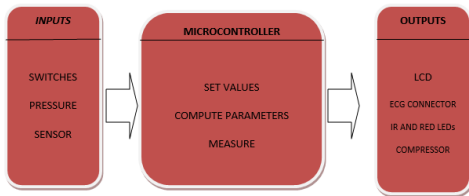

Figure 1: Block diagram of the processes of the system

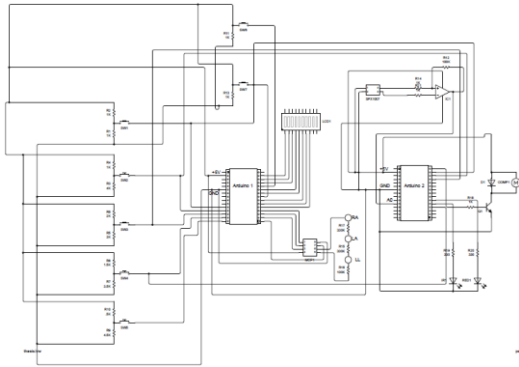

Figure 2: Circuit Diagram of the System

A. System Overview

Three vital signs simulation can be done by the system: ECG simulation; SpO2 simulation and NIBP simulation.

1. For ECG simulation:
The system will wait what type of ECG simulation to be executed. If the user chooses normal simulation, the system will wait for the beats per minute. If the beats per minute are set, the system will produce ECG waveform with a frequency based on the beats per minute. If the user chooses arrhythmia simulation, the system will produce arrhythmia ECG waveform.
2. For SpO2 simulation:
The system will wait for the oxygen saturation level and pulse rate from the user. If the oxygen saturation level and pulse rate are set, the system will adjust the

intensity of the Red and IR LEDs based on the oxygen level set and frequency based on the pulse rate that was set.

3. For NIBP simulation:
The system will wait for the systolic pressure, diastolic pressure, and pulse rate from the user. If the systolic pressure, diastolic pressure and pulse rate are set, the simulation the system will wait if the pressure from the pressure sensor reached the systolic pressure. If the systolic pressure is reached, the system will pulse the compressor based on the pulse rate that was set. The system will continue to measure the pressure. If the pressure reaches the diastolic pressure, the system will stop the compressor signifying the end of the NIBP simulation.

III. RESULTS AND DISCUSSION

A. ECG Simulation Testing

Different beats per minute were tested and measured using an oscilloscope to measure the actual beats per minute of the system. 30bpm, 60 bpm, 90 bpm, 120 bpm and 150 bpm [2] were set and 30 trials for each setting were conducted.

Table 1
Summary of ECG Heart Rate Testing

Heart Rate	μ expected	μ simulator
30 bpm	0.5 Hz	0.5 Hz
60bpm	1 Hz	1 Hz
90 bpm	1.5 Hz	1.5 Hz
120 bpm	2 Hz	2 Hz
150 bpm	2.5 Hz	2.5 Hz

Upon doing 30 trials for each heart, the difference between the expected and the actual output of the simulator was less than 5% and that is why the difference was insignificant.

PQRST waveform of the ECG was set to a normal value, where P = 0.1mV, QRS= 1mV and T = 0.2 mV based on the normal ECG voltage value [3]. Testing was done on a 90 bpm setting with a repetition of 30. Oscilloscope was used to measure the peak voltages of each segment of an ECG waveform.

Table 2
Summary of ECG Voltage Testing

ECG Segment	μ expected	μ simulator
P	0.1 mV	0.1 mV
QRS	1 mV	1 mV
T	0.2 mV	0.2 mV

Upon doing 30 trials for measuring the different segments of the ECG waveform, the difference between the expected and the actual output of the simulator was less than 5% and therefore the difference was insignificant.

B. Pulse Oximeter Simulation Testing

Different oxygen concentration level was tested and measured using an oscilloscope. Each oxygen level percentage was measured based on the duty cycle of each pulse to be delivered for Red and IR LED. 60%, 80%, and 99% [4] oxygen level settings was used and 30 trials was conducted .

Table 3
Summary of pulse oximeter LED Time on Testing

Oxygen Saturation	μ expected	μ simulator
60% (Red)	0.6 sec	0.6 sec
60% (IR)	0.4 sec	0.4 sec
80% (Red)	1.2 sec	1.2 sec
80% (IR)	0.3 sec	0.3 sec
99% (Red)	1.98 sec	1.98 sec
99% (IR)	0.02 sec	0.02 sec

Upon doing 30 trials for each saturation percentage for both IR and Red LED, the difference between the expected and the actual output of the simulator was less than 5%, therefore the difference was insignificant.

Pulse rate for pulse oximeter simulation was also tested. The frequency of the pulse in the output corresponded to the pulse rate and it was measured using an oscilloscope. 60bpm, 90 bpm and 120 bpm settings was used and 30 trials for each setting were conducted.

Table 4
Summary of Oximeter Pulse Rate Testing

Pulse Rate	μ expected	μ simulator
60bpm	1 Hz	1 Hz
90 bpm	1.5 Hz	1.5 Hz
120 bpm	2Hz	2Hz

Upon doing 30 trials for each pulse rate, the difference between the expected and the actual output of the simulator was less than 5%, therefore, the difference was insignificant.

C. Non Invasive Blood Pressure Simulation Testing

Pressure sensor test was done on the system. This can be done by connecting a voltmeter to the pressure sensor then apply specific pressure. The measured voltage of the voltmeter for that specific pressure was compared to the voltage drop in the specification sheet with a sensitivity of 0.127 mV/mmHg. 50mmHg, 100mmHg and 150mmHg [5] settings were used and 30 trials for each setting were done.

Table 5
Summary of NIBP Pressure Sensor Testing

Pressure	μ expected	μ simulator	Difference	Percentage
50 mmHg	6.35 mV	6.353 mV	0.003	0.3
100 mmHg	12.7 mV	12.73 mV	0.03	3
150 mmHg	19 mV	18.99	0.01	1

Upon doing 30 trials for each pressure, the difference between the expected and the actual output of the simulator was less than 0.01, therefore the difference was insignificant.

Pulse rate for NIBP simulation was also tested. The frequency of the pulse in the output (compressor) corresponded to the pulse rate and it was measured using an oscilloscope. 60bpm, 90 bpm and 120 bpm settings were used and 30 trials for each setting were done.

Table 6
Summary of NIBP Pulse Rate Testing

Pulse Rate	μ expected	μ simulator
60bpm	1 Hz	1 Hz
90 bpm	1.5 Hz	1.5 Hz
120 bpm	2 Hz	2 Hz

Upon doing 30 trials for each pulse rate, the difference between the expected and the actual output of the simulator was less than 5%, therefore the difference was insignificant.

IV. CONCLUSION

The design was able to attain the three types of simulation as validated by the tests. The design was able to replicate the normal heart's electrical signal and the beats per minute can be adjusted to three different beats per minute (30 bpm, 90 bpm and 120 bpm) by adjusting the frequency of the replicated waveform. The differences between the expected values were not significant for both the waveform and the beats per minute. The design also replicated the absorption properties and pulse rate of a patient by adjusting the percentage of light from infrared and red LEDs. The differences between the expected values were not significant for both the light percentage and the pulse rate. Systolic and diastolic pressures of a patient were simulated by monitoring the pressure in the cuff of the NIBP and replicating the pulse of the patient using a micro compressor. The differences between the expected values were not significant for both the systolic/diastolic pressures and the pulse rate. The three simulations needed to countercheck the performance of a patient monitors were attained by the design. Healthcare facilities maintenance department can use this design to calibrate their patient monitors.

V. RECOMMENDATION

To further increase the function of the design, up to 12 leads should be considered, but additional output may be needed for ECG simulation. Different LEDs should be considered to cover more brands of pulse oximeter since each brand uses different wavelength of LEDs. Optical Character Recognition may be employed to gather the data of the patient monitor being tested in order to provide judgment of the prototype. If judgment will be employed in the future prototype, connectivity to computerized maintenance management system should be employed to document the testing of the patient monitors.

ACKNOWLEDGEMENT

The project was conducted in Mapua Institute of Technology. The authors would like to thanks Malayan Colleges Laguna for supporting this project.

REFERENCES

- [1] Perry, L. & Malkin R. 2011. Effectiveness of Medical Equipment Donations to Improve Health Systems: How Much Medical Equipment is broken in the Developing World? *Medical and Biological Engineering and Computing*. (2): 719–722.
- [2] Salahuddin L, Jeong MG, Kim D. 2007. Ultra Short Term Analysis of Heart Rate Variability using Normal Sinus Rhythm and Atrial Fibrillation EGG Data. *9th International Conference on e-Health Networking, Application and Services IEEE*. 240-243.
- [3] Boudreau C. 2004. *Mosby's Pocket Guide Series Electrocardiography*, 5th edition, Mosby, Missouri.
- [4] Chen, J., Hong, B., Zhang, P. 2013. Design of Pulse Oximeter Simulator Calibration Equipment. *M. Long (Ed): World Congress on Medical Physics and Biomedical Engineering, IFMBE Proceedings*. 39: 1533-1536
- [5] Fuentes, R. & Bañuelos, M. A. 2003. Digital Blood Pressure Monitor. *Journal of Applied Research and Technology*. 2(3): 224-229.
- [6] Pinheiro, E. 2008. Oscillometric Blood Pressure Monitor Modeling. *30th Annual International IEEE EMBS Conference Vancouver, British Columbia, Canada*. 303-306.