

Lie Detection Based EEG-P300 Signal Classified by ANFIS Method

Arjon Turnip, M. Faizal Amri, M. Agung Suhendra, and Dwi Esti Kusumandari
*Technical Implementation Unit for Instrumentation Development,
Indonesian Institute of Sciences, Bandung, Indonesia.
arjon.turnip@lipi.go.id*

Abstract—In this paper, the differences in brain signal activity (EEG-P300 component) which detects whether a person is telling the truth or lying is explored. Brain signal activity is monitored when they are first respond to a given experiment stimulus. In the experiment, twelve subjects whose age are around 19 ± 1 years old were involved. In the signal processing, the recorded brain signals were filtered and extracted using bandpass filter and independent component analysis, respectively. Furthermore, the extracted signals were classified with adaptive neuro-fuzzy inference system method. The results show that a huge spike of the EEG-P300 amplitude on a lying subject correspond to the appeared stimuli is achieved. The findings of these experiments have been promising in testing the validity of using an EEG-P300 as a lie detector.

Index Terms—Lie Detection; ERP; EEG-P300; ANFIS; Feature Extraction; Classification.

I. INTRODUCTION

The lie detector is an instrument that is often discussed or researched by scientists and experts. Because of a number of problems posed by lies and frauds, which be able to lead to criminal activities, lie detector needs to be improved. Many subjects or suspects of criminal activities to lie when questioned by authorities. This shows the importance of tools that can differentiate between a subject who is lie or not.

Currently, the most widely used technique in detecting quantitative discrimination between lies and truthful is a polygraph [1, 2]. Out of Polygraph, Kymograph and Emotograph techniques are also commonly used as a lie detector. This system relies on the response of the autonomic nervous system, which detects the emotional reaction of the subject. Using polygraph as lie detection has several weaknesses, as it has some shortcomings. Therefore, a number of other techniques developed for detecting lies, among other things, lie detection based on electroencephalography (EEG) has been developed [3, 4]. In this research, the ability to analyze the brain wave activity utilized significantly to analyze a person is lying or not. The Lie detection based EEG-P300 signal which noninvasive is proposed [5-8].

Recently, one of the applications in the field of EEG research is how to detect a fraud and lies of human based on brain signals activity. The study focused on the topography and the time domain of event related potential (ERP), which is a form of brain activity. There are many types of existing ERP or EEG signals, depending on the type of provided stimulus and experimental methods. For an example are motor imaginary, P300, SSVEP signals and others [9-13]. The P300 signal is type of frequently EEG used by researchers for different applications. The P300 is a brain wave

that evoked whenever someone saw some objects or stimuli. If the subject has seen stimuli in the form of images passing by, P300 signal will appear later on after 300 ms in the EEG recording machine [14-16].

In this paper, we will discuss about the new methods of lie detection using EEG-P300 analysis between the subjects. There are three types of used stimuli which are probe, target, and irrelevant. Probe (P) stimulus are stimuli with sensitive information, will only be known by the guilty subjects and researchers, whereas in subjects who are not guilty, this type of stimuli will not be affected (not different from irrelevant stimuli). Unlike the stimulus probes, stimulus Target (T) known by anyone, and the subjects were given the command to perform some task when this stimulus appeared. Lastly, stimulation Irrelevant (I) are stimuli that completely unrelated to lying, and thus is not known by all subjects [3].

After the EEG-P300 signals information obtained, the next step to do is classification of the EEG signals. The classification is needed for distinguishing between the EEG-P300 of subjects, that lying or not. In the classification step, MATLAB based algorithm, an Adaptive neuro fuzzy inference system (ANFIS) has been used. The ANFIS has a low computational time because it has capability to learn the system by combining neural network and fuzzy features.

II. METHODS

A. Data Acquisition

In the experiment, the data was recorded from twelve health subjects (10 men and 2 women) with the age around 19 ± 1 years. The EEG data were collected from five Ag/AgCl electrodes embedded in an elastic cap using the Mitsar 202 EEG system. The electrodes that used in this experiment are the frontal (Fz), central (Cz), parietal (Pz), and occipital (O1 and O2) (Figure 1). Further, WinEEG software for EEG recording and the stimuli displayed through PsyTask.

Before the experiment, the subjects were trained on experimental procedures. The subjects were divided into two groups; innocent and lying. They must do some tasks when the objects (P, T, and I stimulus) displayed. The time interval between each stimulus is one second with two second delay. Figure 2 shows an example how the EEG signals of subject is recorded.

B. Signal Processing and Feature Extraction

i. Signal Processing

Once the signals recording was complete, the continuous EEG data from each subject were inspected and filtered for artifacts using band-pass filter and Independent Component Analysis (ICA), respectively. Parts of the signals that

contained noises by task-irrelevant movement or artifact be cut by band-pass filtered using 0.1 Hz and 30 Hz cut-offs [17] and then the noises were removed by ICA.

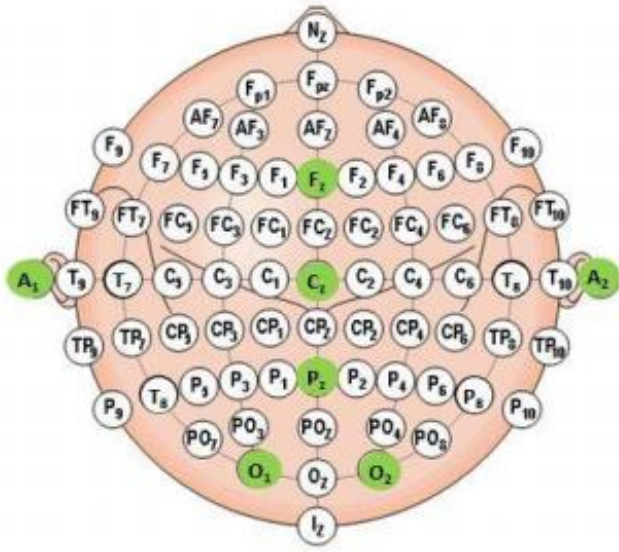

Figure 1: Block diagram of the processes of the system



Figure 2: Experiment setup

The ICA is applied with the assumptions [18, 19]: Data is combination of stable space cerebral activity and independent artifact; Superposition of potentials on many parts of the brain, head skin, linear body of the electrodes, and propagation delay can be neglected; Number of source is not greater than the electrode's. In this paper, the ICA method is used to separate the signals based on P, T, and I stimuli. The ICA is important to blind signal separation. The separation of a set of source signals from a set of mixed signals, without the aid of information about the source signals.

ii. Feature Extraction

The feature extraction can be applied to produce five characteristics of signal P300; minimum amplitude, maximum amplitude, mode amplitude, median amplitude, and mean amplitude. In this research, discrete wavelet transform (DWT) is used as an extraction method. The reason why the wavelet transform has been selected because the component of ERP signal-to-noise ratio (SNR) is low and not stationary

The DWT uses multi filter banks and special wavelet filters for the analysis and reconstruction of signals. The DWT

provides a compact representation of a signal in time and frequency that can be computed efficiently. The method calculates the wavelet coefficients at discrete intervals of time and scale instead of at all scales [20, 21].

C. Classification

An Adaptive Network Fuzzy Inference System (ANFIS) is used as a classifier after signals extraction. The ANFIS is a system of decision-making method that combines Neural Network and Fuzzy [22-24]. It has five layers feedforward neural network which can be seen as in Figure 3. The first layer has work for a fuzzy process from input, the 2nd layer executes the fuzzy and of the antecedent part of the fuzzy rules that got from 1st step process , and for 3rd layer normalizes the membership functions (MFs) from the data, the 4th layer executes the consequent part of the fuzzy rules, and for the last layer computes the output of fuzzy system by summing up the outputs of layer 4th.

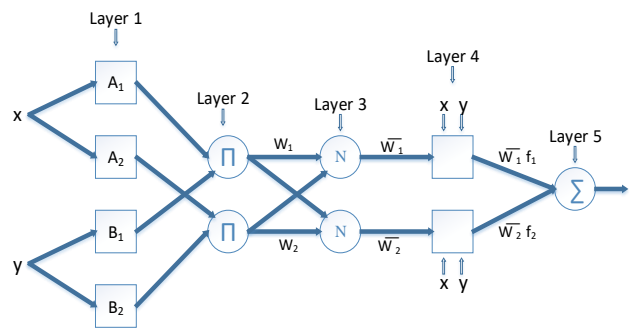

Figure 3: ANFIS architecture

The function [19, 20] output from first layer described as:

$$O_i^1 = \mu_{A_i}(x) \quad , \quad i = 1,2 \tag{1}$$

$$O_i^1 = \mu_{B_{i-2}}(y) \quad , \quad i = 3,4 \tag{2}$$

The 2nd layer of ANFIS has multiplication function that determines the weights of fuzzy rules. In ANFIS there are several rules for the system. These rules are as follows:

$$\text{if } (x = A_1) . (y = B_1) \text{ then } (f_1 = p_1x + q_1y + r_1) \tag{3}$$

$$\text{if } (x = A_2) . (y = B_2) \text{ then } (f_2 = p_2x + q_2y + r_2) \tag{4}$$

Meanwhile, the equation for determining the weight of the rules that have been determined is:

$$O_i^2 = w_i = \mu_{A_i}(x)\mu_{B_i}(y) \tag{5}$$

Variable w is the weight form from the inputs of the layers. The third layer is a normalization layer of the weights that obtained from the second layer. The process of normalization is done with the Equation (6).

$$O_i^3 = \bar{w}_i = \frac{w_i}{w_1 + w_2} \tag{6}$$

The fourth layer, the resulting output is the product of the weight that was normalized with fuzzy rules (f).

Mathematically, the fourth layer has the following equation.

$$O_i^4 = \bar{w}_i f_i = \bar{w}_i (p_i x + q_i y + r_i) \quad (7)$$

The final layer architecture is the total output from the ANFIS layers. In this layer, the entire output of the fourth layer added up, giving a final value output system. The last layer has the following equation.

$$O_i^5 = \sum_{i=1}^2 \bar{w}_i f_i = \frac{\sum_{i=1}^2 w_i f_i}{w_1 + w_2} \quad (8)$$

III. RESULTS AND DISCUSSION

The results of signal from three stimuli responses which are produced through signal processing, response from P stimuli has the most important information in determining whether subjects are lying or not. Before we got the signal features that affected by P stimuli, preprocessing signals and feature extraction had been through. After band pass filter applied, the ICA method was adopted to separate non-P300 signal response i.e. noises or artifacts signal. Then the P300 signals that still contain high noises were reconstructed, before extracted with DWT. The DWT has function for extracting the P300 signals based on what kind of stimuli that provided (P, T or I stimuli). Lastly, two different class of feature samples were used to train the ANFIS classifier. This method, that proposed in this paper, improves the results and efficiency of lying detection application based on EEG-P300 Signal.

The results from signal processing can be seen from the figures below. The EEG RAW data of subject 1 (Figure 4) shows very large amplitude, -3332 to 1324 μV . It very different from the EEG signals amplitude that known, the EEG signal normal value is about 100 μV . It shown the RAW data contaminated by noise or artifacts.

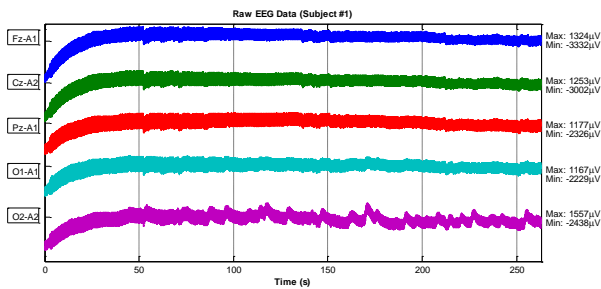

Figure 4: EEG RAW data subject 1

The RAW signals of EEG-P300 with removed offset, filtered, and extracted signals are respectively given in Figures 5-7. The EEG signals were extracted using DWT is used as trial data based on times of subjects was demonstrated by Psytask stimuli. The red circle from figure 6, demonstrated the activity from P300 signals at Cz electrode.

IV. CONCLUSION

The ANFIS method applied at the features classification step has the advantage of much less training time is achieved. The results indicated that the existing method in this article had great result for lie detection. The ANFIS method is able

to separate lying subjects from honest subjects based on EEG-P300 signals with an accuracy of 64.27%.

ACKNOWLEDGEMENT

This research was supported by the thematic program through the Bandung Technical Management Unit for Instrumentation Development (Deputy for Scientific Services) funded by Indonesian Institute of Sciences, Indonesia.

Table 1
Classification Result

Subjects	Accuracy (%)	Result of Classification
1	88.75	Classified
2	60	Unclassified
3	68.75	Classified
4	75	Classified
5	68.75	Classified
6	76.25	Classified
7	75	Classified
8	70	Classified
9	65	Unclassified
10	32.5	Unclassified
11	47.5	Unclassified
12	56.25	Unclassified

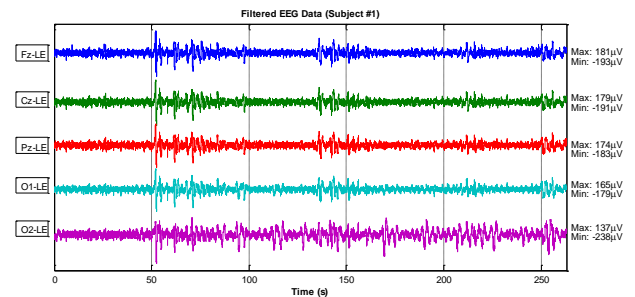

Figure 5: The filtered signal subject 1 with Band Pass Filter

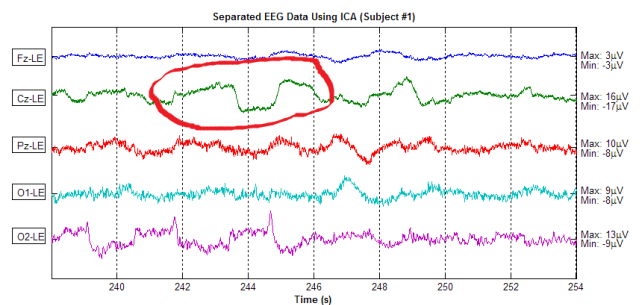

Figure 6: The Extracted Signals using the ICA method

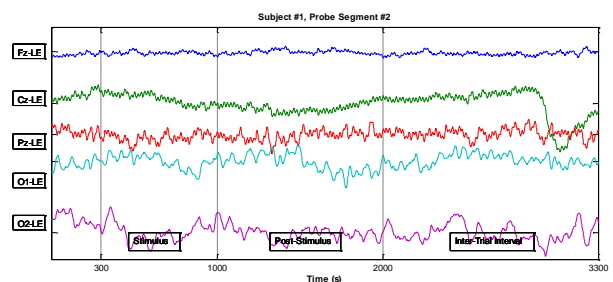

Figure 7: Segmented EEG signal subject 1 (Stimuli Probe)

REFERENCES

- [1] Rosenfeld J.P., Shue E. and Singer E. 2007. Single Versus Multiple Probe Blocks Of P300-Based Concealed Information Tests For Selfreferring Versus Incidentally Obtained Information. *Biological Psychology* 74:396-404.
- [2] Bhutta M. R. and Hong K. 2015. Classification Performance Analysis Of Combined Fnr-Polygraph System Using Different Temporal Windows. 2015 15th International Conference on Control, Automation and Systems no. Iccas.1795–1800
- [3] Gao J. and Rao N. 2012. A New Lie Detection Method based on Small-number of P300 Responses.
- [4] Abootalebi V., Moradi M. H., and Khalilzadeh M. A. 2009. A new approach for EEG feature extraction in P300-based lie detection, *Comput. Methods Programs Biomed.* 94(1): 48–57,.
- [5] Gao J., Yan X., Sun J., and Zheng C. 2010. Denoised P300 and machine learning-based concealed information test method. *Comput. Methods Programs Biomed.*, 104(3):410–417
- [6] Sellers E. W., Krusienski D. J., Mcfarland D. J., Vaughan T. M., and Wolpaw J. R. 2006. A P300 event-related potential brain – computer interface (BCI): The effects of matrix size and inter stimulus interval on performance. 73: 242–252
- [7] Turnip A., Hong K., and Jeong M. 2011. Real-time feature extraction of P300 component using adaptive nonlinear principal component analysis.1–20,.
- [8] Turnip A. and Hong K. S. 2012. Classifying mental activities from EEG-P300 signals using adaptive neural network. *Int. J. Innov. Comp. Inf. Control* . 8(7)
- [9] Turnip A., Hutagalung S. S., Pardede J., and, Soetraprawata D. 2013. P300 detection using multilayer neural networks based adaptive feature extraction method. *International Journal of Brain and Cognitive Sciences.* 2(5):63-75,
- [10] Turnip A. and Siahaan M. 2014. Adaptive Principal Component Analysis based Recursive Least Squares for Artifact Removal of EEG Signals. *Advanced Science Letters.* 20(10-12):2034-2037
- [11] Krusienski D. J., Sellers E. W., Bayouh S., Mcfarland D. J., Vaughan T. M., and Wolpaw J. R. 2006. A comparison of classification techniques for the P300 Speller. 299.
- [12] Turnip A. and Siahaan M. 2013. P300 Detection Using Nonlinear Independent Component Analysis. 1:104–109,.
- [13] Dehzangi O., Jafari R., and Zou Y. 2013. Simultaneous Classification of Motor Imagery and SSVEP EEG Signals. 6–8,.
- [14] Turnip A. and Hutagalung S. S. 2013. P300 Detection based on Extraction and Classification in online BCI. 1.
- [15] Turnip A. and Kusumandari D. E. 2014. Improvement of BCI performance through nonlinear independent component analysis extraction. *Journal of Computer.* 9(3):688-695.
- [16] Turnip A., Haryadi, Soetraprawata D., and Kusumandari D. E. 2014. Comparison of Extraction Techniques for the rapid EEG-P300 Signals. *Advanced Science Letters.* 20(1):80-85
- [17] Tahir M., Mitsuhashi W., and James C. J. 2012. Employing spatially constrained ICA and wavelet denoising , for automatic removal of artifacts from multichannel EEG data. *Signal Processing,* 92(2):401–416.
- [18] Liao J., Shih W., Huang K., and Fang W. 2013. An Online Recursive ICA Based Real-time Multi- channel EEG System on Chip Design with Automatic Eye Blink Artifact Rejection. 1–3.
- [19] Ayoubian S., Member S., Qazi S., and Member S. 2006. Wavelet Filtering of the P300 Component in Event-Related Potentials. 1719–1722.
- [20] Patil S. S. 2012. Quality advancement of EEG by wavelet denoising for biomedical analysis. 1–6.
- [21] Abbasimehr H. 2011. A Neuro-Fuzzy Classifier for Customer Churn Prediction. 19(8):35–41.
- [22] Ramírez-cortes J. M., Alarcon-aquino V., Rosas-cholula G., Gomez-gil P., and Escamilla-ambrosio J. 2010. P-300 Rhythm Detection Using ANFIS Algorithm and Wavelet Feature Extraction in EEG Signals. 1.
- [23] Turnip A., Simbolon A. I., and Amri M. F. 2015. Utilization of EEG-SSVEP method and ANFIS Classifier for Controlling Electronic Wheelchair. 43–146.
- [24] Azeez D., Alauddin M., Ali M., Gan K., and Saiboon I. 2013. Comparison of adaptive neuro-fuzzy inference system and artificial neural networks model to categorize patients in the emergency department. 1–10.