

# Integrated Stacked Microstrip Antenna with Light Emitting Diode (LED) for Wi-Fi Application

Hamizan Yon, Aziati H. Awang, M. T. Ali, S. Subahir, S.N. Kamaruddin, M.A.Aris and Norfishah Ab Wahab  
*Antenna Research Group (ARG), Microwave Technology Center (MTC), Faculty of Electrical Engineering, Universiti Teknologi MARA, Shah Alam, Selangor 40450, Malaysia.*  
*hamizan2816@salam.uitm.edu.my*

**Abstract**—Investigation of Light Emitting Diode (LED) integrated with a rectangular stacked microstrip antenna is presented in this paper. The antenna designed at 2.45 GHz to support Wi-Fi applications. The antenna is simulated by using Computer Simulation Technology (CST). The LEDs are located at the top layer as the parasitic element, while patch radiator located at the second substrate. Meanwhile, ground plane and feed line are located on the bottom substrate. Simulated and measured results are compared to identify the feasibility of proposed integrated antenna. The performances of rectangular stacked microstrip antenna in term of return loss, gain and radiation pattern was verified. Result between simulation and fabrication shows that antenna potentially provide a new opportunity to introduce dual functionality.

**Index Terms**—About CST; FR4 substrate; Light Emitting Diode (LED); Rectangular Microstrip Patch Antenna; Wi-Fi.

## I. INTRODUCTION

Demand for new technologies has been increased worldwide. Wireless communication system per say is one of the tremendous technologies that has seen an increase in its research advance. For versatility and practically wise, wireless hardware is in need to be integrated with other components whether for one functionality or multi functionality. The combination of Wi-Fi antenna and LED has produced a new concept of dual functionality in wireless communications and lighting systems. Currently, plasma antenna is one of the antennas that have dual function development in wireless communication technology especially in indoor Wi-Fi communication. The antenna system can be used as transmitter and receiver for communication purposes and at the same time, as illumination source to user [1], [2]. However, plasma antenna technology has a major disadvantages, expensive and difficulties to manufacture. Meanwhile plasma requires energy to be ionized and the gas is more complex and expensive [3]. The volume of mercury inside plasma also can harm the safety and not supporting green technology [1].

It is feasible that LED can be used to be integrated with microstrip antenna [1], [4], [5]. This dual functionality systems in a device provides wireless communication and at the same time as illumination source. Previously LED has been used for communication only for visible light communication (VLC). VLC allows Light Emitting Diode (LED) to transfer data from one transmitter to other recipient.

For example, VLC can be employed for toys car or may allow a magic wand to control light effects on a dress [6], [7]. By using LED light, VLC allowing the toys to communicate with each other. However, the fundamental elements of VLC system are devices that offer low data rate and it is used for signal modulation and control device. To combine these technologies together is difficult because VLC and wireless communication system is of different frequencies and the antenna module architecture is complicated to design for frequency conversion. [1], [4], [5] Enhanced LED technology with new concept integration of LED with the antenna for Wi-Fi communication is proposed. However the authors realize LED might have some effect on the performance of their antenna because of the copper material that exists on the base of LED itself.

Microstrip antenna has been widely used because of their advantages. The small size of the antenna is one of the reasons the researcher used microstrip antenna. These advantages will provide capabilities to design microstrip antenna with more than one application in a single device [8]. Easier to design and fabricate and relatively low cost, compact low-profile configuration and the possibility of wrapping the antenna around the cylinder or aircraft fuselage by printing the elements on a flexible substrate material are amongst other advantages of microstrip antenna [8]. Although the microstrip antenna possess lot of advantages, this microstrip has some limitation. Among them are loss from leakage at the open boundary, small radiated power and bandwidth, low power handling capabilities and limited gain [8].

From the concept of plasma as an antenna in communication and lighting purposes, LED is an advancement that offers lot of advantages especially on green technology, low power and easy integration. LEDs are posed to replace incandescent and fluorescent lamps on the next generation and predicted to become a key component in future indoor illumination [1]. The structure of the bottom conductor material placed between the gap of LED are the copper, which is used for soldering anode and cathode can also been used as the conductor to the design of Wi-Fi antenna. Although this conductor is useful to be integrated with antenna, the author [1], [5] state that the LED will effect performance of antenna in term of frequency response. In this paper, the design of stacked microstrip antenna integrated with LED has been performed. The size of 1.6mm thickness of FR-4 substrate has been used that operates at 2.45GHz for WI-FI applications. All

the simulation and the measurement results of the stacked microstrip antenna integrated with LED in term of Gain, Bandwidth, S11 and resonant frequency result will be discussed in detail.

## II. ANTENNA DESIGN

The stacked microstrip antenna with LED parasitic element was designed on the three substrate layer FR4 with permittivity 4.3 and thickness 1.6mm as show in Figure 3 where 18 LEDs are soldered on the top substrate with series connection as show in Figure 2. Patch antenna attached on the second layer substrate. The third layers consist of ground plane with slot as aperture and feed line at the back. The surface mount diode (SMD) 5050 LEDs are used in the design because easy to solder and better luminous intensity as show in Figure 1. The 5Vdc bias is connected to switch on the LED.

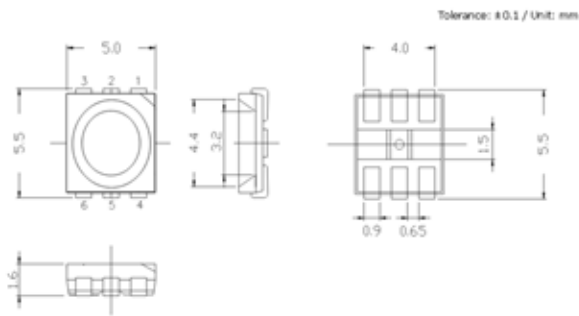

Figure 1: structure of the SMD5050 LED

The general view of parasitic element with and without LED as Figure 2 and Figure 3 shows and Table 1 shows the parameters dimension of the design.

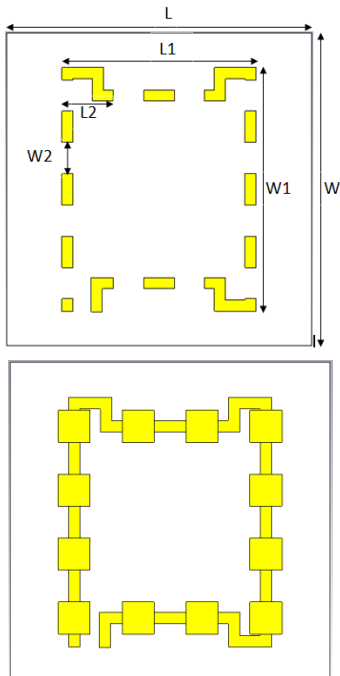

Figure 2: General view top layer with and without LED

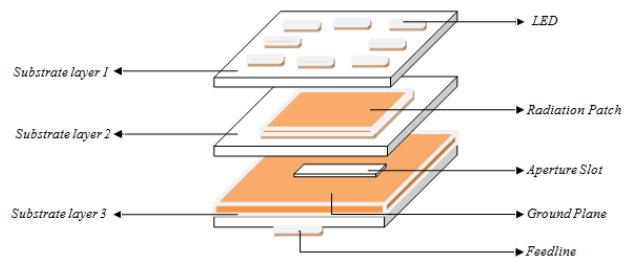

Figure 3: Geometry of radiating patch with LED

Table 1  
Dimensions of rectangular Loop Patch Antenna

Parameter	Value [mm]
Width of substrate, W	50
Width W1	13
Width W2	11
Width of LED W3	5
Width of Patch, Wp	38
Width of Feed line, Wf	4.23
Width of Aperture Slot, Ws	15
Length of Substrate, L	50
Length L 1	37
Length L 2	36
Length of LED L3	5
Length of Patch, Lp	22.28
Length of Feed line, Lf	30

By using the Equation (1) to (4) to determine size of the radiated patch antenna where (l) for length and (w) for width antenna.

$$w = \frac{1}{2f_r \sqrt{\mu_0 \epsilon_0} \sqrt{\epsilon_r + 1}} \quad (1)$$

$$l = \frac{1}{2f_r \sqrt{\epsilon_r \epsilon_{eff}} \sqrt{\mu_0 \epsilon_0}} - 2\Delta L \quad (2)$$

$$\Delta L = \frac{0.412 (\epsilon_r \epsilon_{eff} - 0.3) \left(\frac{W}{h} + 0.264\right)}{h (\epsilon_r \epsilon_{eff} - 0.258) \left(\frac{W}{h} - 0.8\right)} \quad (3)$$

$$\epsilon_r \epsilon_{eff} = \frac{\epsilon_r + 1}{2} + \frac{\epsilon_r - 1}{2} \left[1 + 12 \frac{h}{W}\right]^{-1/2} \quad (4)$$

Additional parasitic element [9], [10] has been installed in this antenna design which was located at the top of the design to achieve better gain and bandwidth for this integrated microstrip antenna. Series connection was used to light up the LED. LED and the power line work as the parasitic element for this design.

## III. SIMULATION AND MEASUREMENT RESULT

### A. Simulation Result Using Computer Simulation (CST)

As mentioned earlier, the proposed antenna was simulated using electromagnetic simulation tool and the characteristic parameter will be comparing the performances of the antenna with and without LED. Referring to Figure 4 the resonant frequency is slightly shifted between with LED and without LED because the effect of the copper from the LEDs structure.

The width of the power line is fixed 1.8mm and 12 of LEDs to ensure antenna resonant at 2.45GHz. Meanwhile, return loss is deeper for the antenna design with LED with increment of -32.698 dB and without LED -14.030dB. The gain obtained for the designed antenna with LED decrease to 3.96 dB compared without LED which is 4.12 dB.

Simulation With and Without LED

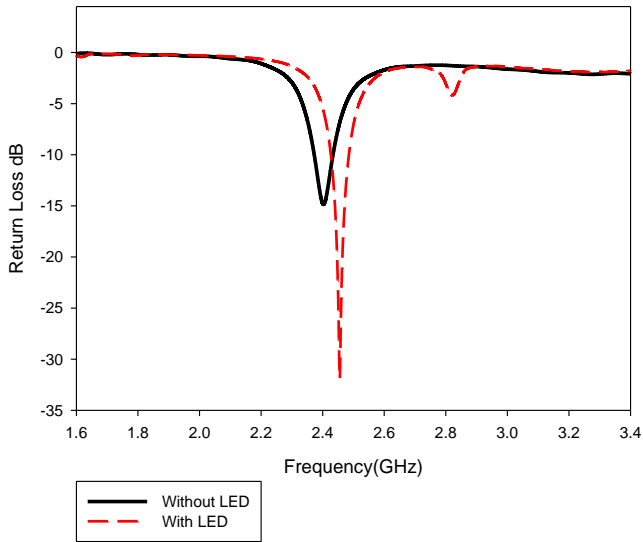

Figure 4: Simulated result return loss without LED and with LED

Polar Plot With and Without LED

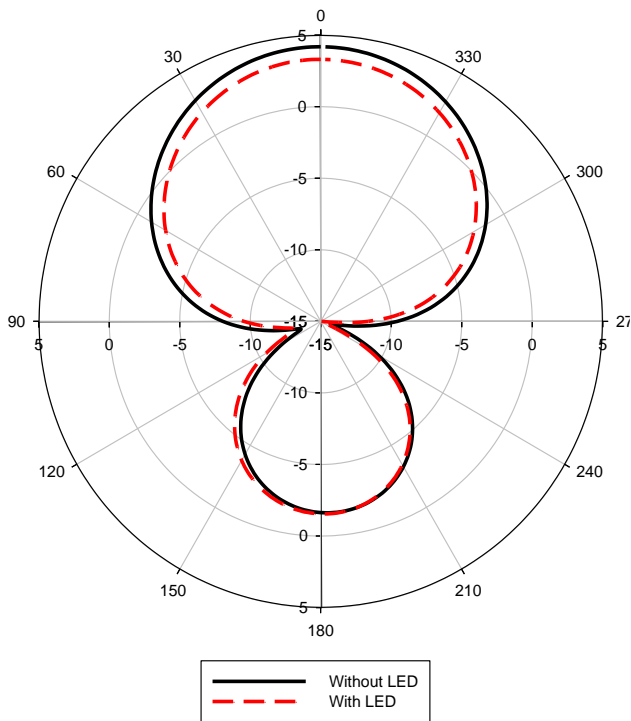
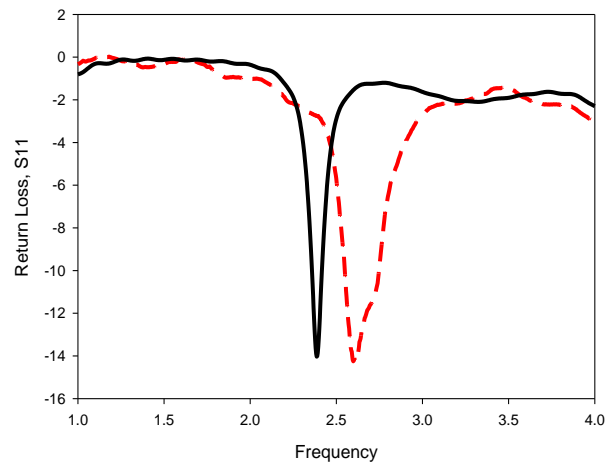

Figure 5: Simulation S11 result with/without LED

**B. Measurement Result Using Vector Network Analyzer**

The optimized structure was fabricated and measurement of S11 was carried out with VNA keysight module. The return loss of the integrated microstrip antenna without LED for both simulation and measurement were shown in Figure 6. The frequency response for both resonant was slightly shifted for both with and without LED to 2.605GHz and 2.628GHz, respectively. We believed that mismatched results between simulated and measurement were contributed by a slight difference in substrate properties which is the permittivity value. On the other hand, S11 value with LED much better as compared to the antenna without LED. The corresponding operating bandwidth were 193.389 MHz in measurement and 143.2MHz at simulation stage for both conditions.

Without LED



With LED

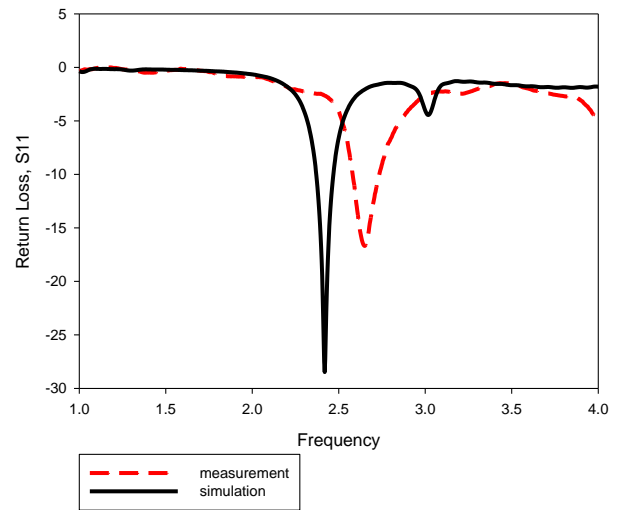

Figure 6: Measurement and simulation without and with LED

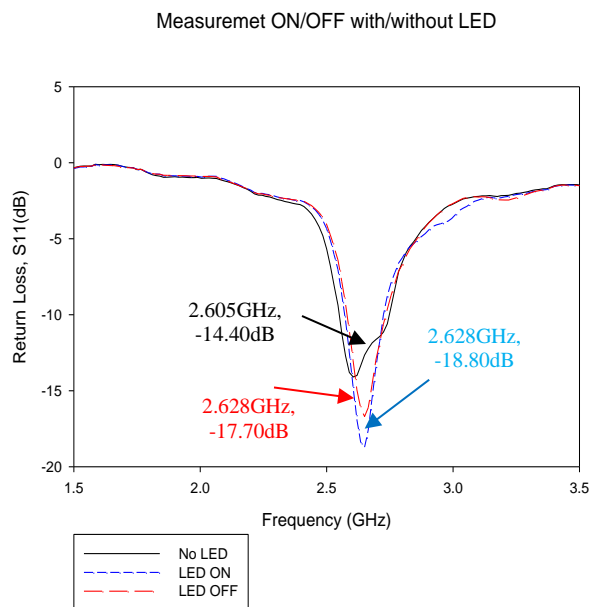

Figure 7: Measurement result for ON/OFF LED

Figure 9 shows a well matched result at the input of antenna where the return loss for OFF LED is -17.70dB simulation at 2.628GHz and return loss of -18.08dB and 2.628GHz respectively for ON LED. The corresponding operating bandwidth are 156.219 MHz at LED ON state and 152.878 MHz at LED OFF state. The results shows a shifted frequency compared with simulation result and it may be caused by the fabrication process and soldering effect of LED terminal on the patch.

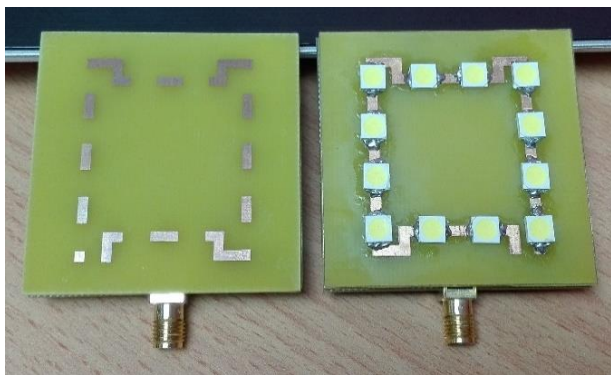

Figure 8: Fabricated rectangular stack antenna integrated with LED

#### IV. CONCLUSION

The rectangular stack microstrip patch antenna integrated with LED has been designed and the performance has been investigated. From this paper, it can be concluded that, the designed antenna contributes to dual-function in a device. It

can function as an antenna at WI-FI frequencies and at the same time it provides illumination to user without major effect to the performance of the antenna with and without LED. The measurement proves that LED can be assumed as a parasitic element to the antenna and well matched to the patch to improve gain of the antenna. The measurement also proves, the frequency response for both resonant is stable for both condition ON and OFF to 2.628GHz and 2.628GHz, respectively. Meanwhile the return loss for ON condition is higher with value of -18.80dB and -17.70dB for LED OFF. The use of the integrated LED in the design supports the green environment and will contribute to energy saving. However, future works will be considered to improve this antenna to have better performance in term of gain and bandwidth

#### ACKNOWLEDGMENT

The authors would like to thank Universiti Teknologi MARA for sponsoring the work. Express gratitude to the members of the Antenna Research Group ARG Antenna Research Group, Faculty of Electrical Engineering, Universiti Teknologi MARA (under RAGS/1/2014/TK03/UITM//11) for supporting the research work.

#### REFERENCES

- [1] S.Subahir,M.T.Ali, N.A Ramli, S.N. Kamaruddin, A.H.Awang, M.R. Kamaruddin, "Development of Rectangular Loop Microstrip Antenna Integrated With Light Emitting Diode (LED) for Wi-fi Application", *The International Electrical Engineering Congress (iEECON 2015)*, March 18-20, 2015.
- [2] H.M Zali, M.T Ali, I.Pasya, N.A Halili, H.Ja'afar, M.Hilmi "Design of a Cylindrical parabolic reflector on Monopole Plasma Antenna", in *2013 IEEE International RF and Microwave Conference (RFM2013)*, 2013.
- [3] V. Kumar, M. Mishra, and N. K. Joshi, "Study Of A Fluorescent Tube As Plasma Antenna" *Progress In Electromagnetics Research Letters*, Vol. 24, 2011, pp. 17-26
- [4] M.S Amari, S.Subahir, M.T. Ali, N.A Ramli, S.N. Kamaruddin "Rectangular Spiral Microstrip Patch Antenna Integrated With LED For Wi-Fi Application", *The 2nd IEEE International Symposium on Telecommunication Technologies (ISTT2014)*, 2014.
- [5] S.N. Kamarudin, M.T. Ali, S. Subahir, A.A. Azlan, S. Muhamud-Kayat, Muhammad Ramlee Kamarudin "Design and Investigation of H-Shaped Patch Antenna Integrated with Light Emitting Diodes", *The International Electrical Engineering Congress (iEECON 2015)*, March 18-20, 2015
- [6] Corbellini, S. Schmid, S. Mangold, T. R. Gross, and A. Mkrtychyan, "LED-to LED Visible Light Communication for Mobile Applications," in *Demo at ACM SIGGRAPH MOBILE 2012*, 2012.
- [7] N. O. Tippenhauer, D. Giustiniano, and S. Mangold, "Toys communicating with LEDs: Enabling Toy Cars Interaction," in *Demo at Consumer Communications and Networking Conference, CCNC, IEEE*, 2012
- [8] Robert E. Collin, "Antenna and Radiowave Propagation", McGraw-Hill Book Company, New York 1985
- [9] M.A.Aris, M.T.Ali, N.H.Abd Rahman, "Frequency Reconfigurable Microstrip Array Antenna using Periodic Defected Ground Structure"
- [10] A. Abbosh and M. Bialkowski, "Design of UWB Planar Band-Notched Antenna Using Parasitic Elements", *IEEE Transactions on Antennas and Propagation*, 2009, pp. 796-799.